



Multilingual Robotics Glossary: South African Languages Version



Reclaiming Africa's Intellectual Futures

Define tomorrow.

UNISA





**Multilingual Robotics Glossary:
South African Languages Version**

ENGLISH VERSION 1				
with equivalents in				
Sepedi	Sesotho	Setswana	Xitsonga	Tshivenda
isiZulu	isiXhosa	isiNdebele	siSwati	Afrikaans

University of South Africa
Preller St, Muckleneuk, Pretoria, 0002
PO Box 392, UNISA, 0003

Unisa is the largest open distance learning institution in Africa, the longest standing dedicated distance education university in the world.

© English text, University of South Africa, 2023

Copyright Statement

As the user of this text, you are free to Share — copy and redistribute the material in any medium or format; Adapt — remix, transform, and build upon the material. The licensor cannot revoke these freedoms as long as you follow the license terms:



Attribution — You must give appropriate credit, provide a link to the license, and indicate if changes were made. You may do so in any reasonable manner, but not in any way that suggests the licensor endorses you or your use.



Non-Commercial — You may not use the material for commercial purposes.



ShareAlike — If you remix, transform, or build upon the material, you must distribute your contributions under the same license as the original.

No additional restrictions — You may not apply legal terms or technological measures that legally restrict others from doing anything the license permits.

A-Z headword text set in 22pt bold Arial, definitions in 12pt Arial, a sans-serif typeface by Monotype Corporation.

Table of Contents

Copyright Statement.....	vii
Preface.....	ix
Acknowledgements.....	x
Coordinating Team	x
Language Contributors.....	x
Explanatory Notes.....	xi
Aa.....	1
Bb.....	4
Cc.....	6
Dd	11
Ee.....	12
Ff.....	14
Gg.....	17
Hh	19
Ii.....	21
Jj.....	23
Kk	24
Ll.....	26
Mm.....	29
Nn	30
Oo.....	32
Pp.....	35
Rr	37
Ss.....	40
Tt.....	44
Uu	46
Vv.....	47
Ww.....	50
Yy.....	51
Different Types of Robots	52
Advanced Drive Base Spike Prime Disassembled	53
Labelled Robot.....	54
References	54

Preface

This glossary is a product of Inspired towards Science, Engineering and Technology (I-SET), a community engagement flagship project of the College of Science, Engineering and Technology (CSET). In collaboration with the Department of Linguistics and Modern Languages, and the Department of African Languages, the project has endeavoured to make robotics resources available in all South African official languages. The first step of that mission was to produce this multilingual glossary of terms.

Over the years, I-SET has been engaging in focus groups when conducting I-SET robotics workshops for learners, educators, buddy training and the public at large. However, since the beginning of the pandemic, I-SET has been hosting I-SET live online learning workshops that are open to the public through Microsoft Teams. Every week I-SET presents a different hour-long workshop that includes engagement with the participants. The workshops have been doing exceptionally well and the participation analytics speak for themselves. The learning content of most of the sessions is available on the Unisa MOOC portal at <https://mooc.unisa.ac.za/portal>. For more information, visit the [I-SET website](#) or find us on [Facebook](#) and [Twitter](#). To request the monthly schedule of I-SET Robotics Live Online Learning activities, please e-mail I-SET@unisa.ac.za.

This text comprises some 100 term records, which were defined to facilitate the secondary term creation process handled by the collaborators.

The compilers of this booklet do not claim that it is comprehensive or entirely without errors and scope for improvement. Feedback, especially on the layout, the accuracy of the equivalents and the comprehensiveness of the glossary, will be welcomed.

The compilers of this glossary hope that it will make a difference to mother-tongue robotics education in classrooms throughout the country.

January 2023
Pretoria

Acknowledgements

Many thanks go to all the collaborators in various languages for their great assistance in the finalisation of the project. This collaboration consisted of first language speakers of the target languages and robotics experts. These collaborators were linguists, language practitioners, quality assurers of the respective languages and robotics facilitators and lecturers. Their involvement was critical to the success of the Multilingual Robotics Glossary: South African Languages Version. This work is based on a project partially supported by the South African Centre for Digital Language Resources (SADiLaR).

Coordinating Team

Dr Napjadi Letsoalo (Linguistics Project Leader)
Dr Patricia Gouws (Robotics Project Leader)
Mr Delvah Mabaso (Auxiliary Researcher)
Dr Kganathi Shaku (Glossary Concept Co-Founder)
Mr Jimmy Mabina (Project Coordinator)

Language Contributors

Name	Language
Mr Maropeng Maponya	Sepedi
Dr Napjadi Letsoalo	
Ms Mamoya Letseleha	Sesotho
Ms Pamla Ditsele	Setswana
Ms Neliswa Mzimba	isiXhosa
Ms Thobile Mncube	isiZulu
Ms Thabisile Mchunu	
Ms Christinah Mabena	isiNdebele
Ms Snegugu Vilakazi	siSwati
Mr Delvah Mabaso	Xitsonga
Ms Dakalo Takalani	Tshivenda
Dr Letsoalo & Gouws	English
Dr Gouws	Afrikaans

ISET Team

Andzani Sibiyi and Kabelo Pheeha

Layout by

Napjadi Letsoalo (using TshwaneLex)

Graphics by

Casper van Staden and Tumelo Nhlapo

Explanatory Notes

Glossary entry

The terminological information is contained in the glossary entries in the alphabetical section of the glossary. The treatment of the entries contains equivalents of the ten official languages.

Source language

The source language, that being English for this glossary version, is the language in which the terms were initially collected and documented and for which equivalents were found in the different target languages.

Target language

The language in which an equivalent where applicable were found or coined. This glossary incorporates Sepedi, Sesotho, Setswana, Xitsonga, Tshivenda, isiZulu, isiXhosa, isiNdebele, Siswati and Afrikaans as target languages.

Treatment of the entries

Headword

Each glossary entry consists of a headword in the source language, which is English. All headwords appear in bold print and the size of the letters is slightly bigger than that of the equivalents. The following information is provided for headwords:

part of speech – is indicated by the editorial parenthesis with the label of the part of speech like (*noun*)

definition – each headword has a meaning provided in English as the source language

illustration – pictures are provided to illustrate how a treated headword looks like; not all the headwords in the alphabetical list have an illustration

equivalents – a treated headword is accompanied by equivalents from Sepedi, Sesotho, Setswana, Xitsonga, Tshivenda, isiZulu, isiXhosa, isiNdebele, Siswati and Afrikaans as target languages

History is not going to look kindly on us if we just keep our head in the sand on ... robotics issue because it sounds too science fiction.

- Peter Singer

Aa

actuator *(noun)*

a power mechanism used to effect motion, or maintain position of the robot (for example, a motor which converts electrical energy to effect motion of the robot); the actuator responds to a signal received from the control system

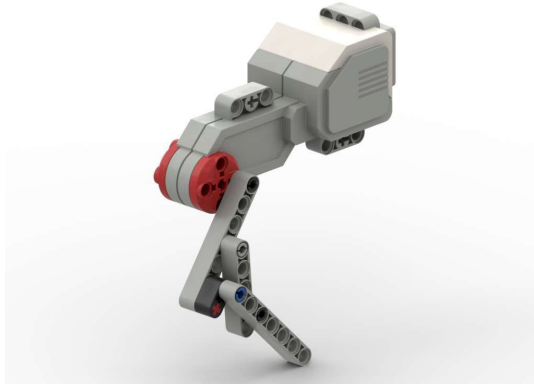

Equivalents

Sepedi selaolatsamayo	Sesotho selaolatsamao	Setswana setlhotlheletsatsamao	Xitsonga xisihalarisi	Tshivenda tshilaulautshimbila
isiZulu isinyakazisi	isiXhosa isishukumisi	isiNdebele isilawulimkhambo	siSwati sinyakatsi	Afrikaans aandrywer

arm *(noun)*

an interconnected set of links and powered joints comprising a robot manipulator that supports and/or moves a wrist and hand or end-effector through space



Sepedi letsogo	Sesotho letsoho	Equivalents Setswana letsogo	Xitsonga voko	Tshivenda tshanda
isiZulu ingalo	isiXhosa ingalo	isiNdebele umkhono	siSwati umkhono	Afrikaans arm

automation *(noun)*

the creation and application of technologies to assume control of processes with minimal human intervention

Sepedi boitiriši	Sesotho boiketsisi	Equivalents Setswana boitirisi	Xitsonga vutiendlisi	Tshivenda vhushumisi
isiZulu okuzenzakalelayo	isiXhosa ukuzenzekelayo	isiNdebele ukuzenzakalela	siSwati lokutentelekayo	Afrikaans outomatisering

axis *(noun)*

a direction used to specify the robot motion in a linear or rotary mode



Sepedi mothalogare	Sesotho molahare	Equivalents Setswana molagare	Xitsonga xiseketeri	Tshivenda mutalokhethanyo
isiZulu inkabamudwa	isiXhosa isinqumla- mbindini	isiNdebele isikazombelo	siSwati sijubamkhatsi	Afrikaans as

axle (*noun*)

a rod or spindle (either fixed or rotating) passing through the centre of a wheel or group of wheels

**Equivalents****Sepedi**

ase

Sesotho

ase

Setswana

ase

Xitsonga

asi

Tshivenda

ase

isiZuluumphini
wesondo**isiXhosa**

i-asi

isiNdebele

i-asi

siSwati

i-ase

Afrikaans

as

Bb

backlash *(noun)*

a sudden, forceful backward movement arising between parts of a robot

Equivalentents				
Sepedi tlhaelelo	Sesotho poyosekwele	Setswana poelamoragobonako	Xitsonga tlheriselo	Tshivenda khumelamurahu
isiZulu ukuhlehla	isiXhosa ukuhlehla	isiNdebele ukuhlehla	siSwati kuhlehla	Afrikaans weerslag

beam *(noun)*

a structural element that primarily resists loads applied laterally to its axis

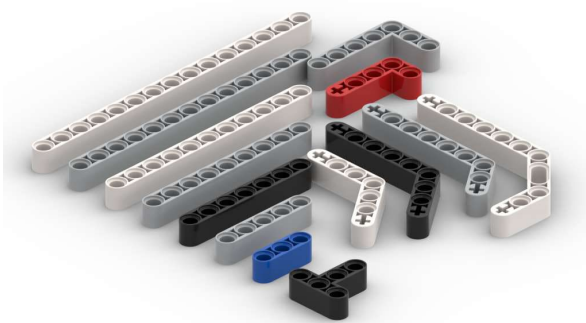

Equivalentents				
Sepedi tlhomešo	Sesotho setheho	Setswana lerang	Xitsonga nseve	Tshivenda musevhe
isiZulu ugongolo	isiXhosa umqadi	isiNdebele ugongolo	siSwati insika	Afrikaans balk

brain *(noun)*

an electronic device which functions as the coordinating centre of the robot's activities



Sepedi
bjoko

Sesotho
boko

Equivalents
Setswana
boboko

Xitsonga
byongo

Tshivenda
vhuluvhi

isiZulu
ubuchopho

isiXhosa
ubuchopho

isiNdebele
ubuchopho

siSwati
bucopho

Afrikaans
brein

button *(noun)*

a small device on a piece of electrical or electronic equipment which is pressed to operate it

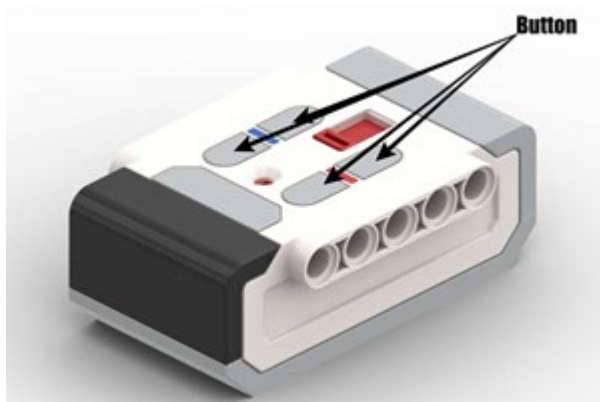

Sepedi
konopo

Sesotho
konopo

Equivalents
Setswana
konopi

Xitsonga
kunupu

Tshivenda
gunubu

isiZulu
inkinobho

isiXhosa
iqhoshha

isiNdebele
inkunubhe

siSwati
likinobho

Afrikaans
knoppie

Cc

carousel *(noun)*

a rotating platform that delivers objects to a robot and serves as an object queuing system; this carousel delivers the objects, or work pieces, to the loading/unloading station of the robot

Equivalents				
Sepedi semono	Sesotho serekolohi	Setswana setlisadidirisiwa	Xitsonga xichuluri	Tshivenda kharosele
isiZulu okujikajikayo	isiXhosa unojikeleza	isiNdebele ikharozeli	siSwati kharozeli	Afrikaans mallemeule

centre of gravity *(noun)*

a point from which the weight of a body or system may be considered to act

Equivalents				
Sepedi kgogedigare	Sesotho khohelihare	Setswana bogarekgogedi	Xitsonga xikarhi ka misava	Tshivenda tshikati tsha mutsiko
isiZulu inkabasisindo yokuwayo	isiXhosa umbindi wesitsaleli- zantsi	isiNdebele ikaba yedoselophasi	siSwati inkhaba yesisindvo	Afrikaans swaartepunt

clamp *(noun)*

an accessory device or tool, specifically designed for attachment to the robot wrist or tool mounting plate to enable the robot to grasp and release an object



coach

colour sensor

Sepedi
sepatiši

Sesotho
setlamahanyi

Equivalents
Setswana
setlapisi

Xitsonga
ximanyiso

Tshivenda
tshifarisi

isiZulu
ikilampu

isiXhosa
unominxi

isiNdebele
itlempe

siSwati
sikhaceki

Afrikaans
klamp

coach *(noun)*

an instructor or trainer who gives extra teaching

Sepedi
mohlahli

Sesotho
mokwetlisi

Equivalents
Setswana
mokatisi

Xitsonga
mudzaberi

Tshivenda
mugudisi

isiZulu
umqeqeshi

isiXhosa
umqeqeshi

isiNdebele
umbanduli

siSwati
umcecheshi

Afrikaans
afrigter

collaboration *(noun)*

the action of working with someone to produce something

Sepedi
tšhomišano

Sesotho
tshebedisano

Equivalents
Setswana
perekisano

Xitsonga
tirhisano

Tshivenda
tshumisano

isiZulu
ukusebenzisana

isiXhosa
intsebenziswano

isiNdebele
ukusebenzisana

siSwati
lubambiswano

Afrikaans
samewerking

colour sensor *(noun)*

a device which emits light to detect the colour of a surface



competition

control device

Sepedi
sekwammala

Sesotho
sensara ya
mmala

Equivalents
Setswana
thupammala

Xitsonga
xitwimuhlovo

Tshivenda
tsumbamuvhala

isiZulu
inzwa mibala

isiXhosa
isiva-mbala

isiNdebele
isizweleli
sombala

siSwati
umuva
wembala

Afrikaans
kleursensor

competition *(noun)*

an event or contest in which people take part to establish superiority or supremacy in a particular area

Sepedi
phadišano

Sesotho
tlhodisano

Equivalents
Setswana
kgaisano

Xitsonga
mphikizano

Tshivenda
muṭaṭisano

isiZulu
umncintiswano

isiXhosa
ukhuphiswano

isiNdebele
iphaliswano

siSwati
umncintiswano

Afrikaans
kompetisie

control device *(noun)*

any piece of control hardware providing a means for human intervention in the control of a robot or robot system, such as an emergency-stop button, a start button, or a selector switch



Sepedi
sedirišwataolo

Sesotho
sesebediswataolo

Equivalents
Setswana
sediriswataolo

Xitsonga
nchumulawuri

Tshivenda
tshishumiswandauli

isiZulu
idivayisi
yokulawula

isiXhosa
isixhobo
sokulawula

isiNdebele
isisetjenziswa
sokulawula

siSwati
sisetjentiswa
sekulawula

Afrikaans
beheertoestel

controller *(noun)*

an information processing device whose inputs are both the desired and measured position, velocity or other pertinent variables in a process and whose outputs are drive signals to a controlling motor or actuator



Sepedi
selaoli

Sesotho
selaoli

Equivalents
Setswana
selaoli

Xitsonga
xilawuri

Tshivenda
tshilanguli

isiZulu
isilawuli

isiXhosa
isihluzi-lwazi

isiNdebele
isilawuli

siSwati
silawuli

Afrikaans
beheerder

control mode *(adjective)*

the means by which instructions are communicated to the robot



creativity

		Equivalents		
Sepedi mokgwataolo	Sesotho mokhoataolo	Setswana mokgwataolo	Xitsonga vulawuri	Tshivenda vhulauli
isiZulu indlela yokulawula	isiXhosa indlela yokulawula	isiNdebele endlela yokulawula	siSwati simo sekulawula	Afrikaans beheerwyse

creativity (*noun*)

the use of imagination or original ideas to create something; inventiveness

		Equivalents		
Sepedi boithomelo	Sesotho boiqapelo	Setswana boitlhamedi	Xitsonga vutumbuluxi	Tshivenda vhutsila
isiZulu ubuhlakani	isiXhosa ubuchule	isiNdebele ukuthama	siSwati ukusungula	Afrikaans kreatiwiteit

cycle (*noun*)

a single execution of a complete set of moves and functions contained within a robot program

		Equivalents		
Sepedi modikologo	Sesotho mopotoloho	Setswana tsheko	Xitsonga vurhendzeleki	Tshivenda tshitendeledzi
isiZulu umjikelezo	isiXhosa umjikelo	isiNdebele isehlakalomzombe	siSwati umjikeleto	Afrikaans siklus

Dd

down *(adverb)*

towards or in a lower place or position

		Equivalents		
Sepedi	Sesotho	Setswana	Xitsonga	Tshivenda
fase	fatshe	fatshe	ehansi	fhasi
isiZulu	isiXhosa	isiNdebele	siSwati	Afrikaans
ezansi	phantsi	phasi	entasi	af

downtime *(noun)*

a period of time, in which, a robot or production line is shut down, due to malfunction or failure

		Equivalents		
Sepedi	Sesotho	Setswana	Xitsonga	Tshivenda
kemišotšhomo	kemisotshebetso	kemisotiro	nkarhietlela	nyimisolshumo
isiZulu	isiXhosa	isiNdebele	siSwati	Afrikaans
ukumiswa komsebenzi	ukunqamka kwemveliso	ukucima	kuma kwetinhlelo	stilstaantyd

drop *(verb)*

let or make (something) fall

		Equivalents		
Sepedi	Sesotho	Setswana	Xitsonga	Tshivenda
wiša	diha	diga	wisa	wisa
isiZulu	isiXhosa	isiNdebele	siSwati	Afrikaans
wisa	wisa	wisa	wisa	laat val

Ee

end-effector *(noun)*

an accessory device or tool, specifically designed for attachment to the robot wrist or tool mounting plate to enable the robot to perform its intended task

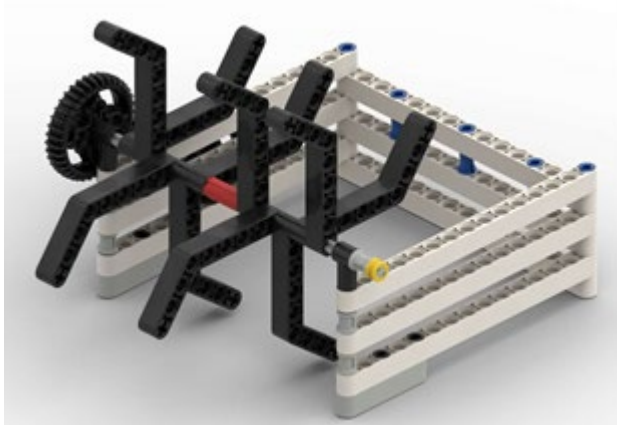

Equivalents

Sepedi
morumoatla

Sesotho
qetello-tsoho

Setswana
sepatagangwaletsweleng

Xitsonga
xandlamakumu

Tshivenda
tshishumiswa
ndanguli

isiZulu
umphumela
wesiphetho

isiXhosa
isixhobomphetho

isiNdebele
isiphethomkhono

siSwati
lesemphethweni
wemkhono

Afrikaans
eindeffektor

endpoint *(noun)*

the nominal commanded position that a manipulator will attempt to achieve at the end of a path of motion

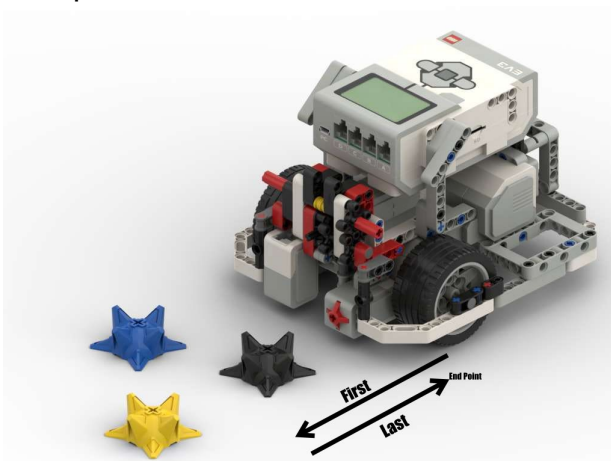

engineering

Equivalents				
Sepedi bofelo	Sesotho boqetelo	Setswana sekhutlokemo	Xitsonga vugimi	Tshivenda magumo
isiZulu isiphetho	isiXhosa isiphelo	isiNdebele umphetho	siSwati siphefto	Afrikaans eindpunt

engineering *(noun)*

the branch of science and technology concerned with the design, building, and use of engines, machines, and structures

Equivalents				
Sepedi boentšenerere	Sesotho boenjinerere	Setswana boenjenere	Xitsonga vuijnhiniyara	Tshivenda vhuinzhiniara
isiZulu ubunjiniyela	isiXhosa ubunjinelili	isiNdebele ubunjiniyera	siSwati bunjiniyela	Afrikaans ingenieurswese

engineering design process *(noun)*

a series of steps that engineers follow to create functional products and processes and come up with a solution to a problem

Equivalents				
Sepedi kgatharollo tshepedišo ya boentšenerere	Sesotho tsamaiso ya boqapi ba boenjinerere	Setswana tsamaiso ya boakanyetso jwa boenjenere	Xitsonga endlelo ra ku khavisa swa vuijnhiniyara	Tshivenda nḽila ya u dzudzanya ya vhuinzhiniyara
isiZulu inqubo yobunjiniyela	isiXhosa inkqubo yoyilo lobunjinelili	isiNdebele ikambiso yabosonjiniyera yokutlama	siSwati incubomgomo yebucwephehe bebunjiniyela	Afrikaans ingenieursontwerp- proses

Ff

facilitator *(noun)*

a person who helps a group of people to work together better, understand their common objectives, and plan how to achieve these objectives, during meetings or discussions

		Equivalents		
Sepedi	Sesotho	Setswana	Xitsonga	Tshivenda
monolofatši	motataisi	monolofatsi	muolovisi	mutshimbidzi
isiZulu	isiXhosa	isiNdebele	siSwati	Afrikaans
umqondisi	umququzeleli	umenzilula	umcondzisi	fasiliteerder

feedback *(noun)*

the return of information from a manipulator or sensor to the processor of the robot to provide self-correcting control of the manipulator

		Equivalents		
Sepedi	Sesotho	Setswana	Xitsonga	Tshivenda
poelo	tlahelo	tsibogo	mbuyelo	ndulamiso
isiZulu	isiXhosa	isiNdebele	siSwati	Afrikaans
impendulo	impendulo	umbiko obuyako	imphendvulo	terugvoer

feedback control *(noun)*

a type of system control obtained when information from a manipulator or sensor is returned to the robot controller in order to obtain a desired robot effect

		Equivalents		
Sepedi	Sesotho	Setswana	Xitsonga	Tshivenda
selaolapoelo	selaolatlahelo	selaolatsibogo	vulawula mbuyelo	ndangulo ya ndulamiso
isiZulu	isiXhosa	isiNdebele	siSwati	Afrikaans
isilawulampendulo	isilawuli- mpendulo	ilawulo lombiko obuyako	kulawulwa kwemphendvulo	terugvoerbeheer

feedback sensor *(noun)*

a mechanism through which information from sensing devices is fed back to the robot's control unit

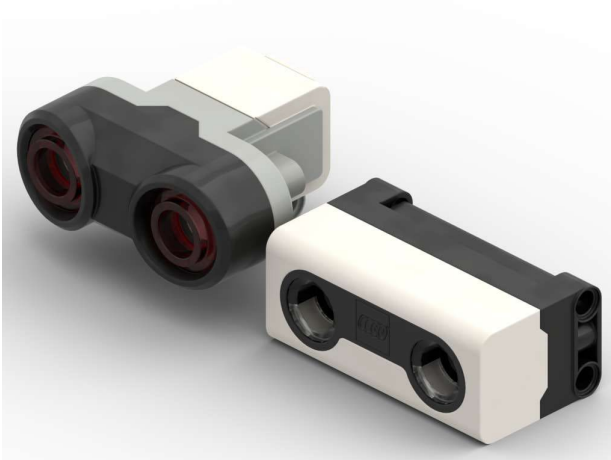

Sepedi
sekwapoelo

Sesotho
sentsara ya
tlahelo

Equivalents
Setswana
thupatsibogo

Xitsonga
xitwimbuyelo

Tshivenda
sentsara ya
ndulamiso

isiZulu
inzwa
yempendulo

isiXhosa
isiva-mpendulo

isiNdebele
isizweleli
sambiko
obuyako

siSwati
umuva
wemphendvulo

Afrikaans
terugvoersensor

follow *(verb)*

move or travel behind

Sepedi
latela

Sesotho
latela

Equivalents
Setswana
latela

Xitsonga
landzela

Tshivenda
tevhela

isiZulu
landela

isiXhosa
landela

isiNdebele
landela

siSwati
landzela

Afrikaans
volg

force sensor *(noun)*

a sensor capable of measuring the forces and torque exerted by a robot and its wrist; such sensors usually contain strain gauges

frame

		Equivalents		
Sepedi sekwamaatla	Sesotho sensara ya matla	Setswana thupamaatla	Xitsonga xitwimatimba	Tshivenda sentsara ya maanda
isiZulu inzwa yamandla	isiXhosa isiva-mandla	isiNdebele isizweleli samandla	siSwati umuva wemandla	Afrikaans kragSENSOR

frame *(noun)*

a coordinate system used to determine a position and orientation of an object in space, as well as the robot's position within its model

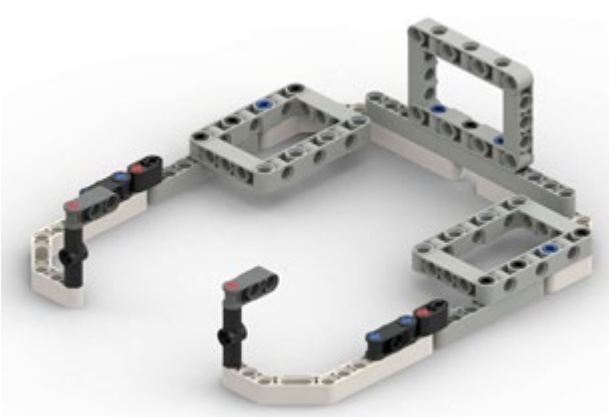

		Equivalents		
Sepedi kagelo	Sesotho kahelo	Setswana kagelo	Xitsonga rimba	Tshivenda ṭhanganyandauli
isiZulu isakhelo	isiXhosa isakhelo	isiNdebele isakhelo	siSwati sakhelo	Afrikaans raam

friction *(noun)*

the action of one surface or object rubbing against another

		Equivalents		
Sepedi kgohlano	Sesotho kgohlano	Setswana kgotlhano	Xitsonga nkhuhlano	Tshivenda tsetana
isiZulu ukugudlana	isiXhosa ukhuhlwano	isiNdebele iruhlano	siSwati kuhhudlana	Afrikaans wrywing

Gg

gear *(noun)*

a toothed wheel that works with others to alter the relation between the speed of a robot and the speed of the wheels



Sepedi
kere

Sesotho
kere

Equivalents
Setswana
kere

Xitsonga
gere

Tshivenda
gere

isiZulu
igiya

isiXhosa
igiya

isiNdebele
igere

siSwati
ligiya

Afrikaans
rat

grab *(verb)*

to get hold of by or if by catching up with the hand



gripper

Equivalents				
Sepedi swara	Sesotho tshwara	Setswana tshwara	Xitsonga khoma	Tshivenda fara
isiZulu bamba	isiXhosa bamba	isiNdebele bamba	siSwati bamba	Afrikaans gryp

gripper *(noun)*

an end effector that is designed for seizing and holding and grips or grabs an object; it is attached to the last link of the arm; it may hold an object using several different methods, such as: applying pressure between its fingers, or may use magnetization or vacuum to hold the object, etc

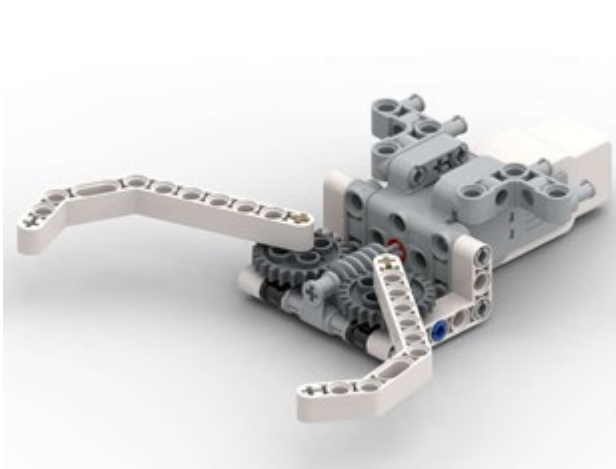

Equivalents				
Sepedi sengamarela	Sesotho setshwari	Setswana sengangatlela	Xitsonga bobochani	Tshivenda bobodzhani
isiZulu isibamba ngqi	isiXhosa isixhakamfuli	isiNdebele isibambi	siSwati sibambi	Afrikaans gryper

Hh

hand *(noun)*

a clamp or gripper used as an end-effector to grasp objects

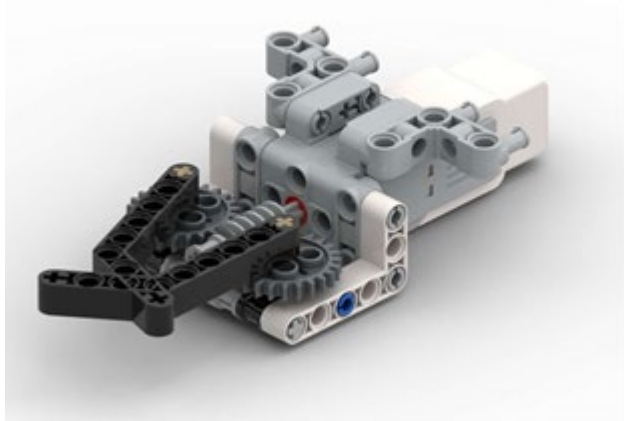

Sepedi
seatla

Sesotho
seatla

Equivalents

Setswana
seatla

Xitsonga
xandla

Tshivenda
tshanda

isiZulu
isandla

isiXhosa
isandla

isiNdebele
isandla

siSwati
sandla

Afrikaans
hand

hold *(noun)*

a stopping of all movements of a robot during its sequence, in which some power is maintained on the robot; for example, program execution stops, however power to the servo motors remain on, if restarting is desired

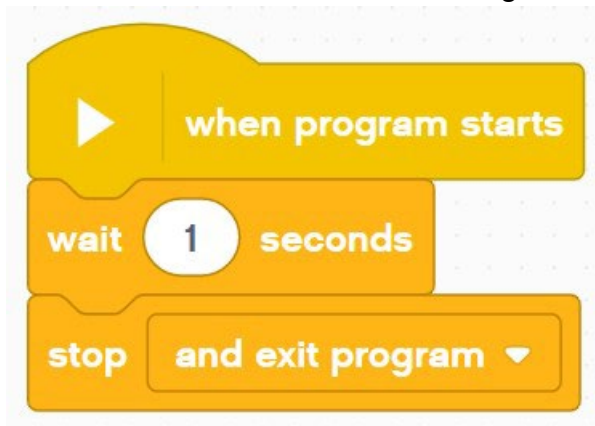

		Equivalents		
Sepedi kemišo	Sesotho kemiso	Setswana kemiso	Xitsonga yimiso	Tshivenda nyimiso
isiZulu ukumisa	isiXhosa unqumamo	isiNdebele ukujama	siSwati kuma	Afrikaans konstant hou

li

imagination *(noun)*

the ability of the mind to be creative or resourceful

		Equivalents		
Sepedi boikgopolelo	Sesotho boinahanelo	Setswana boikakanyetso	Xitsonga mianakanyo	Tshivenda mihumbulo
isiZulu umcabango	isiXhosa umbono	isiNdebele okubonwa ngengqondo	siSwati umcabango	Afrikaans verbeelding

innovation *(noun)*

a new method, idea, product, etc. that creates value

		Equivalents		
Sepedi popomfsa	Sesotho boqapi	Setswana popontšhwa	Xitsonga vutumbuluxi	Tshivenda vhubveledzi
isiZulu inqubo entsha	isiXhosa usungulo	isiNdebele ukuthoma kabutjha	siSwati lisu	Afrikaans innovasie

input *(noun)*

energy supplied to a device or system; an electrical signal

		Equivalents		
Sepedi setsenywa	Sesotho phepelo	Setswana setsenngwa	Xitsonga xinghenisiwa	Tshivenda ndongwa
isiZulu okufakwayo	isiXhosa umfakwa	isiNdebele okufakwako	siSwati lokufakwako	Afrikaans invoer

instruction

instruction *(noun)*

a line of programming code that causes action from the system controller

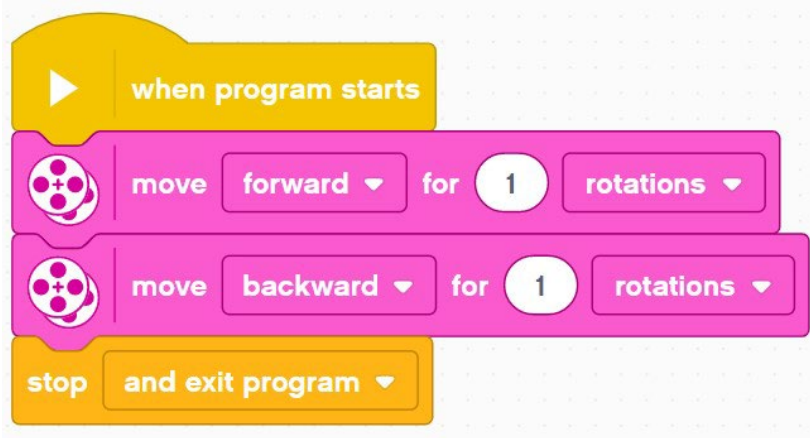

Equivalents

Sepedi
taelo

Sesotho
taelo

Setswana
taelo

Xitsonga
xiletelo

Tshivenda
ndaela

isiZulu
umyalelo

isiXhosa
umyalelo

isiNdebele
ilayelo

siSwati
sicondziso

Afrikaans
instruksie

Jj

joint *(noun)*

a part of the manipulator system, which allows a rotation and/or translational degree of freedom of a link of end-effector

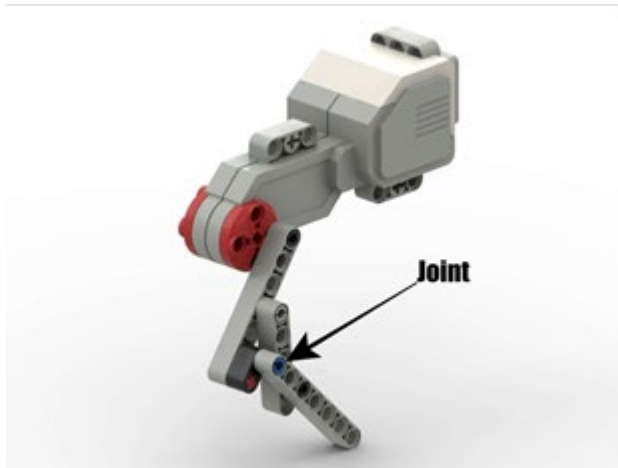

Sepedi
lelokollo

Sesotho
lenonyeletso

Equivalents
Setswana
tokololo

Xitsonga
vuhlanganelo

Tshivenda
ṭhumo

isiZulu
ilunga

isiXhosa
umxokomezelo

isiNdebele
ilungu

siSwati
lilunga

Afrikaans
lasplek

Ll

ladle gripper *(noun)*

an end-effector, which acts as a scoop; it is commonly used to scoop up liquids, transfer it to a mould and pour the liquid into the mould

		Equivalentents		
Sepedi sekgeledi	Sesotho sekgabi	Setswana segeledi	Xitsonga xikeleri	Tshivenda tshifarakhavho
isiZulu isibambo esisakhezo	isiXhosa icephe	isiNdebele isigobho sokubamba	siSwati sigobho sokubamba	Afrikaans skepgryster

laser *(noun)*

a device that produces a coherent beam of light which is extremely narrow and focused but still within the visible light spectrum

		Equivalentents		
Sepedi sentšhasedi	Sesotho sentsakganya	Setswana sentshasedi	Xitsonga xihumesamasana	Tshivenda tshihumisatshedza
isiZulu umsebe kagesi	isiXhosa isitsheka-mlilo	isiNdebele ileyiza	siSwati umsebe wagesi	Afrikaans laser

laser cutting *(noun)*

a precise method of cutting material using a device that emits light

		Equivalentents		
Sepedi mahlasedithipa	Sesotho mahlasedithipa	Setswana sediriswatshego	Xitsonga vutsemamasana	Tshivenda vhudzimatshedza
isiZulu ukusika ngogesi	isiXhosa ukusika ngesitsheka-mlilo	isiNdebele ukusikangomkhanyo	siSwati kusika nga gesi	Afrikaans lasersnit

line

line (*noun*)

a horizontal row

Sepedi
mothalo

Sesotho
mola

Equivalents

Setswana
mola

Xitsonga
ntila

Tshivenda
mutalo

isiZulu
umugqa

isiXhosa
umgca

isiNdebele
umuda

siSwati
lilayini

Afrikaans
lyn

Mm

manipulator *(noun)*

a machine or robotic mechanism of which usually consists of a series of segments (jointed or sliding relative to one another) for the purpose of grasping and/or moving objects (pieces or tools), usually in several degrees of freedom

Equivalentents				
Sepedi	Sesotho	Setswana	Xitsonga	Tshivenda
tšhutadingwe	sefanakataolo	sediriswataolo	xisusamichumu	mutshini ndanguli
isiZulu	isiXhosa	isiNdebele	siSwati	Afrikaans
isisunduzi	unomumatha	ubuqobolwana	sisundzisi	manipuleerder

mechanical efficiency *(noun)*

measure of the effectiveness with which a mechanical system performs

Equivalentents				
Sepedi	Sesotho	Setswana	Xitsonga	Tshivenda
tirišomotšhene	bokgoni ba motjhini	tironatla ya metšhini	vunene bya ximakhinikhi	khalo ya kushumele
isiZulu	isiXhosa	isiNdebele	siSwati	Afrikaans
ukusebenza kahle kwemishini	ukusebenza kakuhle koomatshini	ipumelelo yomtjhini	kusebenta kahle kwemshini	meganiese doeltreffendheid

mentor *(noun)*

a person who trains and guides someone

Equivalentents				
Sepedi	Sesotho	Setswana	Xitsonga	Tshivenda
moeletši	moeletsi	morutuntshi	muleteri	mueletshedzi
isiZulu	isiXhosa	isiNdebele	siSwati	Afrikaans
umeluleki	umcebisi	umyelelisi	umkhutsati	mentor

motor (*noun*)

a device that uses energy to produce movement



Sepedi
mmotho

Sesotho
motho

Equivalents
Setswana
mmotho

Xitsonga
motho

Tshivenda
motho

isiZulu
injini

isiXhosa
injini

isiNdebele
imotho

siSwati
imotho

Afrikaans
motor

move (*verb*)

a change of place or position



Sepedi
šuta

Sesotho
sutha

Equivalents
Setswana
suta

Xitsonga
famba

Tshivenda
sudzuluwa

isiZulu
nyakazisa

isiXhosa
shenxa

isiNdebele
sikinyeka

siSwati
kunyakata

Afrikaans
beweeg

move backward

move backward *(verb)*

to move to a position or in the direction directly behind oneself

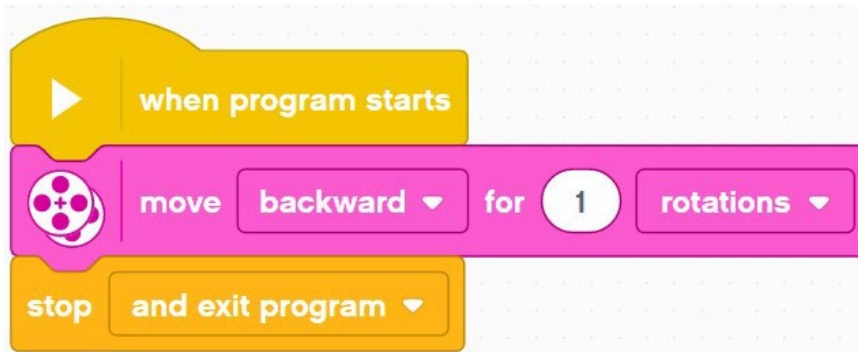

Equivalents				
Sepedi boetša morago	Sesotho ya morao	Setswana boetsa morago	Xitsonga yisa endzhaku	Tshivenda isa murahu
isiZulu yisa emuva	isiXhosa yisa umva	isiNdebele yisa emva	siSwati yisa emuva	Afrikaans beweeg agteruit

move forward *(verb)*

to advance in place, position, or state

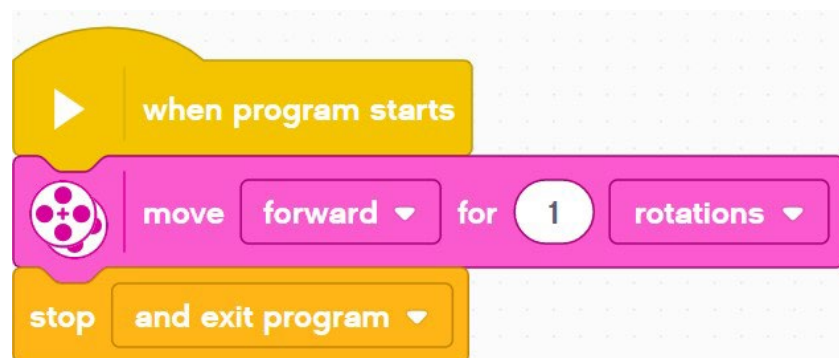

Equivalents				
Sepedi iša pele	Sesotho ya pele	Setswana sutetsa pele	Xitsonga yisa emahlweni	Tshivenda isa phanda
isiZulu yisa phambili	isiXhosa yisa phambili	isiNdebele yisa phambili	siSwati yisa embili	Afrikaans beweeg vorentoe

Nn

navigation *(noun)*

the process or activity of accurately ascertaining one's position and planning and following a route

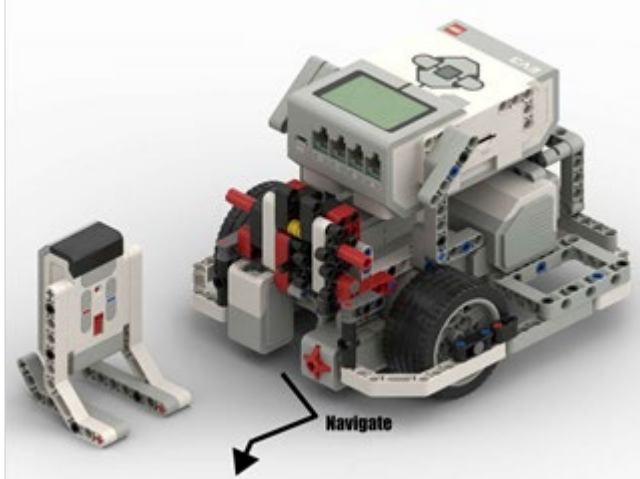

Sepedi
tsamaišo

Sesotho
tsamaiso

Equivalents
Setswana
pheneno

Xitsonga
valanga

Tshivenda
ndavheleso

isiZulu
ukulandela
umzila

isiXhosa
ukukhangela

isiNdebele
ukuhlahindlela

siSwati
kuhlahindlela

Afrikaans
navigasie

Oo

obstacle

a thing that blocks, prevents or hinders progress



Sepedi
lepheko

Sesotho
tshitiso

Equivalents
Setswana
sekgoreletsi

Xitsonga
xirhalanganyi

Tshivenda
tshikundisi

isiZulu
isiphazamiso

isiXhosa
umqobo

isiNdebele
isiliyo

siSwati
sitsikameto

Afrikaans
struikelblok

operator *(noun)*

the person designated to start, monitor and stop the intended productive operation of a robot or robot system

Sepedi
modiriši

Sesotho
mokganni

Equivalents
Setswana
mothudi

Xitsonga
mutirhisi

Tshivenda
mulanguli

isiZulu
umlawuli

isiXhosa
umqhubi

isiNdebele
umlawuli

siSwati
umlawuli

Afrikaans
operateur

output

output *(noun)*

the power, energy, or other results produced, delivered or supplied by a device or system

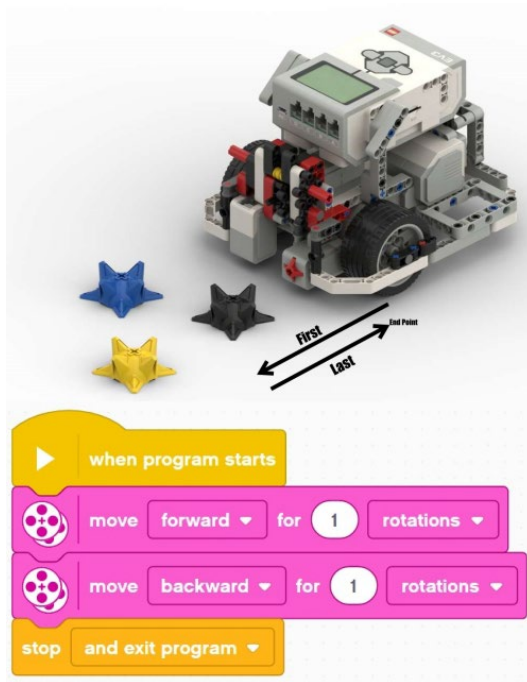

Sepedi
tšweletšo

Sesotho
sephetho

Equivalents
Setswana
tlhagiso

Xitsonga
mbuyelo

Tshivenda
mabveledzwa

isiZulu
umphumela

isiXhosa
isivelisi-
siphumo

isiNdebele
okuphumako

siSwati
umphumela

Afrikaans
uitvoer

over *(adverb)*

extending directly upwards from

Sepedi
ka godimo

Sesotho
ka hodimo

Equivalents
Setswana
kwa godimo

Xitsonga
ehenhla ka

Tshivenda
gonyela nṵha

isiZulu
eqela

isiXhosa
ngaphaya

isiNdebele
ngehla

siSwati
ngetulu

Afrikaans
oor

Pp

path *(noun)*

the continuous locus of positions (or points in three-dimensional space) traversed by the tool center point and described in a specified coordinate system

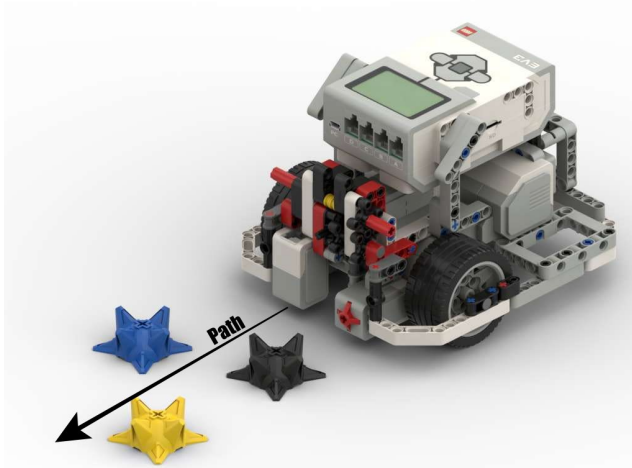

Sepedi
tsela

Sesotho
tsela

Equivalents
Setswana
mmila

Xitsonga
ndlela

Tshivenda
ndila

isiZulu
indlela

isiXhosa
umzila

isiNdebele
indledlana

siSwati
indlela

Afrikaans
pad

pitch *(noun)*

rotation of the end-effector in a vertical plane around the end of the robot manipulator arm

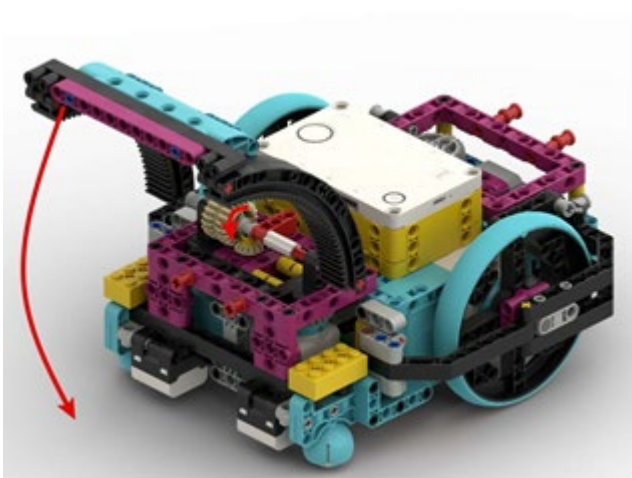

		Equivalents		
Sepedi tsepamologo	Sesotho tsepamoloho	Setswana tsepamologo	Xitsonga vuyisahenhla	Tshivenda vhuisanṭha
isiZulu umugqa ngqo	isiXhosa ujikeleza-nkqo	isiNdebele isiqongo	siSwati kujikeleta-ngco	Afrikaans gooi

power *(noun)*

a source or means of supplying energy



		Equivalents		
Sepedi maatla	Sesotho matla	Setswana maatla	Xitsonga matimba	Tshivenda maanda
isiZulu amandla	isiXhosa amandla	isiNdebele amandla	siSwati emandla	Afrikaans krag

problem-solving *(noun)*

the act of defining a problem; determining the cause of the problem; identifying, prioritizing, and selecting alternatives for a solution; and implementing a solution

		Equivalents		
Sepedi tlemollahuto	Sesotho tharollomathata	Setswana tharabololomathata	Xitsonga vuahlulaxiphiqu	Tshivenda tsenguluso ya thaidzo
isiZulu ukuxazulula inkinga	isiXhosa ukusombulula ingxaki	isiNdebele isisombululimraro	siSwati kuchacha tinkinga	Afrikaans probleemoplossing

process

process *(noun)*

perform a series of mechanical operations on (data) by means of a program

Equivalents				
Sepedi tshepetšo	Sesotho tshebetso	Setswana tirego	Xitsonga matirhelo	Tshivenda mveledziso
isiZulu inqubo	isiXhosa inkqubo	isiNdebele ikambiso	siSwati inchubo	Afrikaans proses

programming *(noun)*

the process or activity of writing computer programs

Equivalents				
Sepedi tIhamotaelo	Sesotho thehataelo	Setswana tIhamotaelo	Xitsonga tumbuluxoletelo	Tshivenda vhophurogiremi
isiZulu ukuhlela	isiXhosa uyilonkqubo	isiNdebele ukuhlela	siSwati kuhlela	Afrikaans programmering

pulley *(noun)*

a wheel on an axle that is designed to support movement of a cable or belt along its circumference

Equivalents				
Sepedi segogi	Sesotho sehudi	Setswana leotwanakgogisi	Xitsonga xikoki	Tshivenda tshikokodzi
isiZulu isidonsi	isiXhosa isitsali	isiNdebele isidonsi	siSwati sidvonsi	Afrikaans katrol

Rr

reach *(noun)*

the volume of space (envelope), which a robot's end-effector can reach in at least one orientation

Equivalentents				
Sepedi bofihlello	Sesotho bofihlello	Setswana bofihlelelo	Xitsonga vufikeleri	Tshivenda tswikelelo
isiZulu ukufinyelela	isiXhosa umthambo	isiNdebele ukufinyelela	siSwati kufinyelela	Afrikaans bereik

robotics *(noun)*

the branch of technology that deals with the design, construction, operation, and application of robots

Equivalentents				
Sepedi thutadiroboto	Sesotho thutadiroboto	Setswana thutadiroboto	Xitsonga dyondzatihoboto	Tshivenda ngudarobotho
isiZulu irobothikhi	isiXhosa irobothikhi	isiNdebele irobothiki	siSwati temarobhothi	Afrikaans robotika

roll *(noun)*

rotation of the robot end effector in a plane perpendicular to the end of the manipulator arm

Equivalentents				
Sepedi potologo	Sesotho potoloho	Setswana tikoloso	Xitsonga khunguluko	Tshivenda khunguluwo
isiZulu ukugingqika	isiXhosa umqengqeleko	isiNdebele ukugedeka	siSwati kugicika	Afrikaans rol

rolling resistance

rolling resistance *(noun)*

the force resisting the motion when a body (such as tyre or wheel) rolls on a surface

Equivalents

Sepedi tshweto	Sesotho kganyetsatheteho	Setswana tilatsamao	Xitsonga vualelakhunguluko	Tshivenda khanelamumono
isiZulu ukuvimbeka komnyakazo	isiXhosa isixhathisi	isiNdebele isijamelimandla	siSwati kuvimbeka kwemnyakato	Afrikaans rolweerstand

Ss

science *(noun)*

the study of the nature and behaviour of natural things and the knowledge that we obtain about them

		Equivalents		
Sepedi thutamahlale	Sesotho thuta-mahlale	Setswana thuto ya maranyane	Xitsonga sayense	Tshivenda saintsi
isiZulu ulwazi lwezemvelo	isiXhosa ezenzululwazi	isiNdebele isayensi	siSwati i-sayensi	Afrikaans wetenskap

sensor *(noun)*

instruments used as input devices for robots, which enable it to determine aspects regarding the robot's environment, as well as the robot's own positioning



		Equivalents		
Sepedi sekwi	Sesotho sensara	Setswana thupa	Xitsonga xitwi	Tshivenda sentsara
isiZulu inzwa	isiXhosa isiva	isiNdebele isizweleli	siSwati umuva	Afrikaans sensor

simulation *(noun)*

a graphical computer program that represents the robot and its environment, which emulates the robot's behaviour during a simulated run of the robot

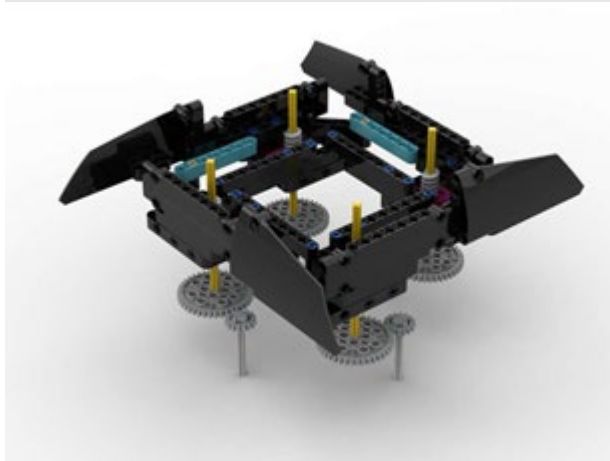

Equivalentents				
Sepedi selaetsakekišo	Sesotho selaetsisi	Setswana selaetsaketsisi	Xitsonga vuecenyeti	Tshivenda tshitevhedzanyito
isiZulu ukulingisa	isiXhosa inkqubo yokulinginisa	isiNdebele ukulingiswa	siSwati kulinginisa	Afrikaans simulasie

spline *(noun)*

a smooth, continuous function used to approximate a set of functions that are uniquely defined on a set of sub-intervals

Equivalentents				
Sepedi theledi	Sesotho theledi	Setswana theledi	Xitsonga xirheti	Tshivenda tshifhedzi
isiZulu imbande	isiXhosa uqikelelo- ntsebenzo	isiNdebele imbande	siSwati imbande	Afrikaans groef

stop

stop (*verb*)

cause (an action, process, or event) to come to a halt

Equivalents				
Sepedi emiša	Sesotho emisa	Setswana emisa	Xitsonga yimisa	Tshivenda imisa
isiZulu misa	isiXhosa misa	isiNdebele jamisa	siSwati misa	Afrikaans stop

Tt

team *(noun)*

a group of players forming one side in a competitive game or sport

Equivalents				
Sepedi sehlopha	Sesotho sehlopha	Setswana setlhopha	Xitsonga xipano	Tshivenda tshigwada
isiZulu iqembu	isiXhosa iqela	isiNdebele isiqhema	siSwati licembu	Afrikaans span

teamwork *(noun)*

the collaborative effort of a group to achieve a common goal or to complete a task in the most effective and efficient way

Equivalents				
Sepedi tšhomišagommogo	Sesotho tshebedisanommoho	Setswana tirisanosenngwe	Xitsonga vutirhahixipano	Tshivenda tshumisano-tshigwada
isiZulu ukusebenzisana kweqembu	isiXhosa ukusebenzisana kweqela	isiNdebele ukusebenzisana kwesiqhema	siSwati kusebentisana kwelicembu	Afrikaans spanwerk

tool *(noun)*

a working apparatus mounted to the end of the robot arm, such as a hand, gripper, welding torch, screw driver, etc

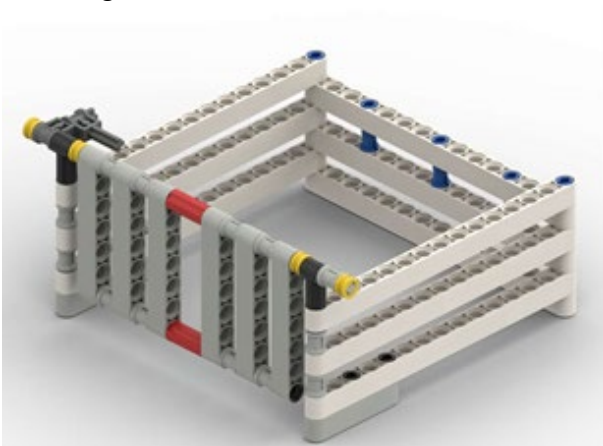

touch sensor

Sepedi setlabelo	Sesotho sesebediswa	Equivalents Setswana sediriswa	Xitsonga xitirho	Tshivenda tshishumiswa
isiZulu ithuluzi	isiXhosa isixhobo	isiNdebele isisetjenziswa	siSwati lithuluzi	Afrikaans gereedskap

touch sensor *(noun)*

an electronic sensor used in detecting and recording physical touch

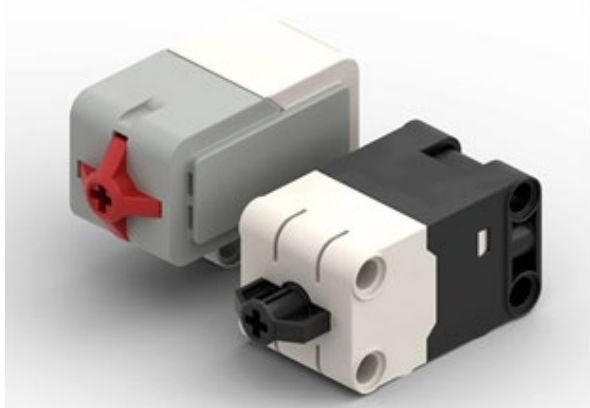

Sepedi sekgwathwo	Sesotho sentsathetso	Equivalents Setswana thupamonwana	Xitsonga xitwikhoma	Tshivenda sentsarapfarwa
isiZulu inzwa yokuthinta	isiXhosa isiva- kuchukumisa	isiNdebele isizweleli sokuthinta	siSwati umuva wekutsintsa	Afrikaans raaksensor

traction *(noun)*

the action of drawing or pulling a tyre on a road or wheel on a rail

Sepedi kgogego	Sesotho bohulo	Equivalents Setswana kgogo	Xitsonga vukoki	Tshivenda vhukoki
isiZulu ukudonseka	isiXhosa ukutsala	isiNdebele ukudosa	siSwati dvonsa	Afrikaans trekkrag

transducer *(noun)*

a device that converts energy from one form to another; generally, a device that converts an input signal into an output signal of a different form

Equivalentents				
Sepedi sefetodi	Sesotho sefetodi	Setswana sefetodi	Xitsonga xihundzuluxantamu	Tshivenda tshirembulusi
isiZulu isiguqulamandla	isiXhosa isiguqulamandla	isiNdebele isitjhugululimandla	siSwati siguculamandla	Afrikaans omvormer

transmission *(noun)*

the act of transferring something from one spot to another

Equivalentents				
Sepedi phetišo	Sesotho phetiso	Setswana phetiso	Xitsonga vufambisi	Tshivenda vhutshimbidzi
isiZulu ukuhambisa	isiXhosa ukuhambisa	isiNdebele ukukhambisa	siSwati kwendlulisa	Afrikaans transmissie

turn *(verb)*

move (something) so as to be aimed or pointed in a particular direction

Equivalentents				
Sepedi retološa	Sesotho reteleha	Setswana retolosa	Xitsonga jikisa	Tshivenda khonisa
isiZulu jikisa	isiXhosa jikisa	isiNdebele jikisa	siSwati jikisa	Afrikaans draai

turn left *(verb)*

move (something) so as to be aimed or pointed in a left direction

turn right

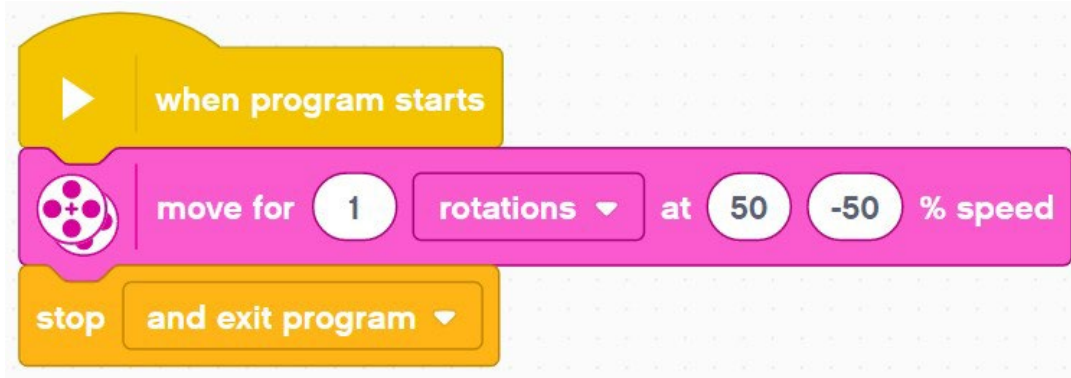

Sepedi
retološetša
nngeleng

Sesotho
reteleha ho le
letshehadi

Equivalents
Setswana
retolosetsa
molemeng

Xitsonga
jikisela
eximatsini

Tshivenda
khonela kha
tshamonde

isiZulu
jikisela
kwesobunxele

isiXhosa
jikisa
ngasekhohlo

isiNdebele
jikisela
ngesinceleni

siSwati
jikisela
ngasesincele

Afrikaans
draai links

turn right *(verb)*

move (something) so as to be aimed or pointed in a right direction

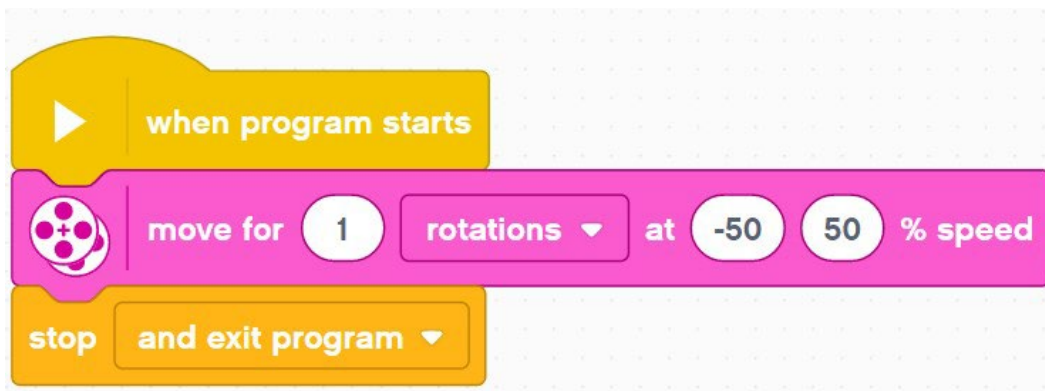

Sepedi
retološetša
gojeng

Sesotho
reteleha ho le
letona

Equivalents
Setswana
retolosetsa
mojeng

Xitsonga
jikisela
exinene

Tshivenda
khonela kha
tshaula

isiZulu
jikisela
kwesokudla

isiXhosa
jikisa
ngasekunene

isiNdebele
jikisela
ngesidleni

siSwati
jikisela
ngasekudla

Afrikaans
draai regs

Uu

ultra-sonic sensor *(noun)*

an electronic device that measures the distance of a target object by emitting ultrasonic sound waves

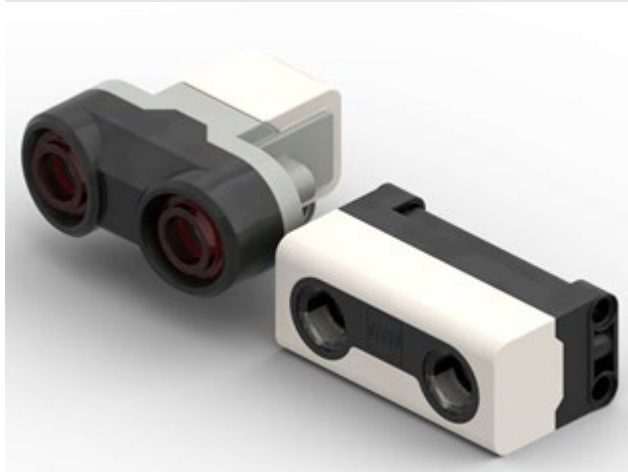

Equivalents

Sepedi sekwaphoto	Sesotho sentsamaqhubu	Setswana sentshatekanyo	Xitsonga xitwimpfumawulo	Tshivenda sentsaraungo
isiZulu inzwa misindo	isiXhosa isivamaza	isiNdebele isizweleli sompumo	siSwati umuvamsindvo	Afrikaans ultrasoniese sensor

under *(adverb)*

extending directly below

Equivalents

Sepedi ka fase	Sesotho ka fatshe	Setswana tlase	Xitsonga ehansi ka	Tshivenda yela fhasi
isiZulu ngaphansi	isiXhosa ngaphantsi	isiNdebele enzasi	siSwati ngephasi	Afrikaans onder

up

up (*adverb*)

towards a higher place or position

Equivalents				
Sepedi godimo	Sesotho hodimo	Setswana godimo	Xitsonga ehenhla	Tshivenda nṭha
isiZulu phezulu	isiXhosa phezulu	isiNdebele phezulu	siSwati etulu	Afrikaans op

uptime (*noun*)

a period of time in which a robot or production line is operating or available to operate

Equivalents				
Sepedi nakotšhomo	Sesotho nakotshebetso	Setswana nakotiro	Xitsonga nkarhianyanya	Tshivenda tshifhingatshumo
isiZulu isikhathi sokusebenza	isiXhosa ixesha lemveliso	isiNdebele isikhathi sokusebenza	siSwati kuchuba kwetinhlelo	Afrikaans bedryfstyd

Vv

vision sensor *(noun)*

a sensor that identifies the shape, location, orientation, or dimensions of an object through visual feedback, such as a television camera



Equivalents

Sepedi
sekwapono

Sesotho
sentsapono

Setswana
thupatshupo

Xitsonga
xitwixivono

Tshivenda
sentsaraṭhaluselamurahu

isiZulu
inzwambono

isiXhosa
isivambono

isiNdebele
isizweleli
sombono

siSwati
umuvambono

Afrikaans
beeldsensor

Ww

weight distribution *(noun)*

the apportioning of weight within a robot

Equivalentents				
Sepedi phatlalatšo ya boima	Sesotho kabo ya boima	Setswana phatlalatso ya boima	Xitsonga xihangalasantiko	Tshivenda phaḁaladzo ya tshileme
isiZulu ukusabalala kwesisindo	isiXhosa ulwabiwo lobunzima	isiNdebele ukwabiwa kobudisi	siSwati kuphakilwa kwesisindvo	Afrikaans gewigsverdeling

wheel *(noun)*

a circular object that revolves on an axle and is fixed below a robot to enable it to move easily over the ground



Equivalentents				
Sepedi leotwana	Sesotho lebiti	Setswana leotwana	Xitsonga vhilwa	Tshivenda linga
isiZulu isondo	isiXhosa ivili	isiNdebele ivili	siSwati lisondvo	Afrikaans wiel

wire (*noun*)

a thin flexible thread or rod



Sepedi
motato

Sesotho
terata

Equivalents
Setswana
mogala

Xitsonga
ntambhu

Tshivenda
ḍaraṭa

isiZulu
ucingo

isiXhosa
ucingo

isiNdebele
idarada

siSwati
luwayela

Afrikaans
draad

workshop (*noun*)

a meeting at which a group of people engage in intensive discussion and activity on a particular subject or project

Sepedi
letšema

Sesotho
letsema

Equivalents
Setswana
letsema

Xitsonga
tsima

Tshivenda
davha

isiZulu
ingqungquthela

isiXhosa
ucweyo

isiNdebele
isifundobandulo

siSwati
ingcungcuthela

Afrikaans
werkswinkel

workspace *(noun)*

the volume of space within which the robot can perform given tasks

Equivalents				
Sepedi bodirelo	Sesotho bosebeletso	Setswana mothamatiro	Xitsonga vutirhelo	Tshivenda vhushumelo
isiZulu indawo yokusebenza	isiXhosa indawo yokusebenzela	isiNdebele indawo yokusebenzala	siSwati indzawo yekusebentela	Afrikaans werkruimte

wrist *(noun)*

a set of rotary joints between the arm and the robot end-effector that allow the end-effector to be oriented to the work-piece; in most cases the wrist can have degrees of freedom which enable it to grasp an object with roll, pitch, and yaw orientation

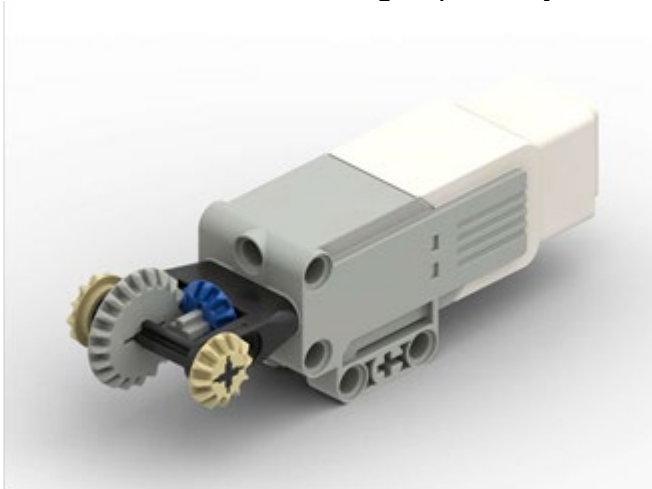

Equivalents				
Sepedi lenakaila	Sesotho manonyeletso	Setswana letswele	Xitsonga xinungu	Tshivenda tshinungo
isiZulu sihlakala	isiXhosa sihlahla	isiNdebele sihlakala	siSwati sihlakala	Afrikaans pols

Yy

yaw (*noun*)

rotation of the end-effector in a horizontal plane around the end of the manipulator arm;
side to side motion at an axis

Equivalents				
Sepedi rapamologo	Sesotho rapamoloho	Setswana rapamologo	Xitsonga vuandlari	Tshivenda vhubuḁa
isiZulu ukujikeleza	isiXhosa jikeleza-tyaba	isiNdebele vundlako	siSwati kujikisa kuvundle	Afrikaans gierbeweging

Different Types of Robots

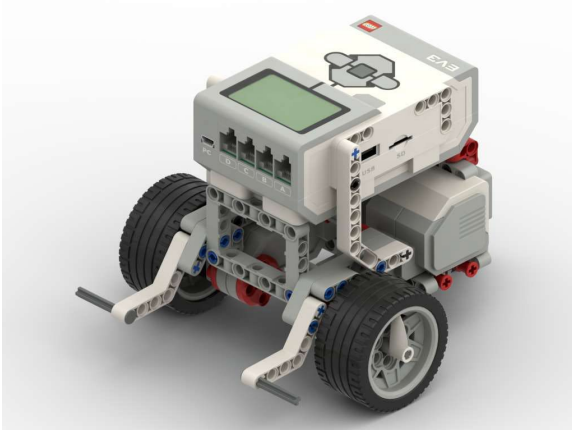

Drive Base EV3

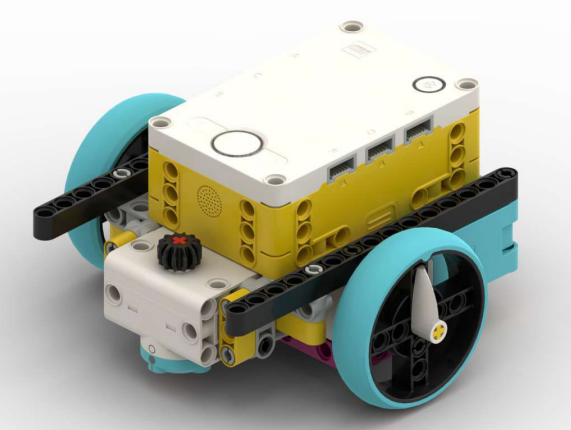

Drive Base Spike Prime

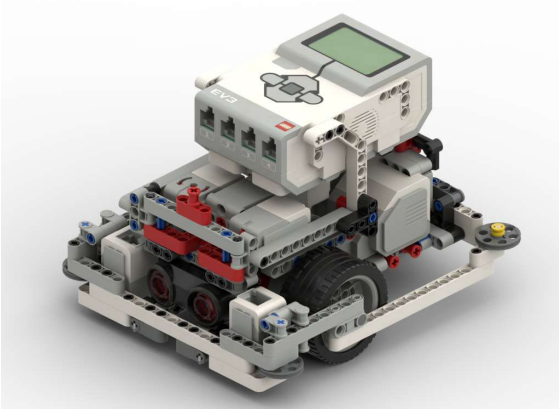

Droid Bot EV3

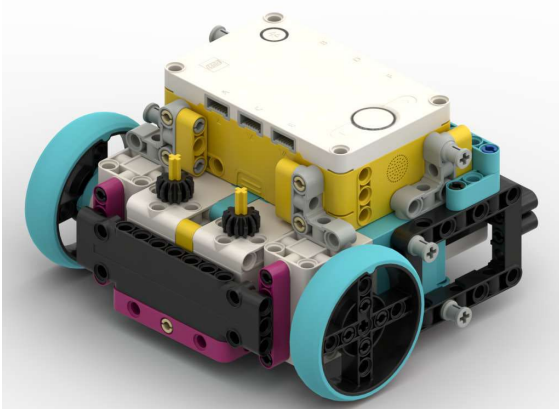

Droid Bot Spike Prime

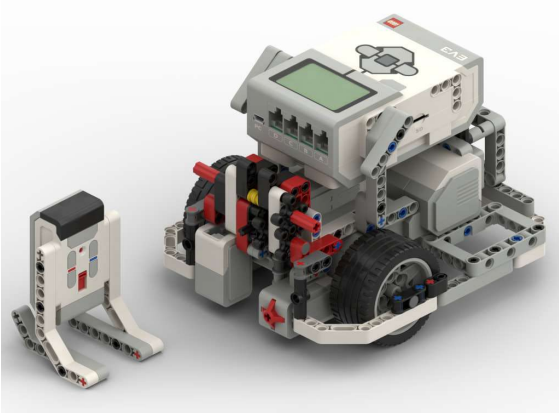

COR3

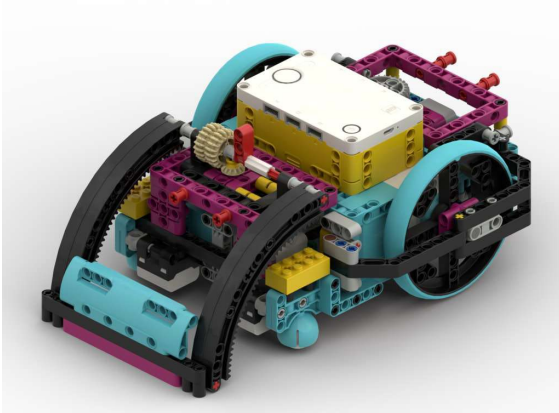

Advanced Drive Base Spike Prime

Advanced Drive Base Spike Prime Disassembled

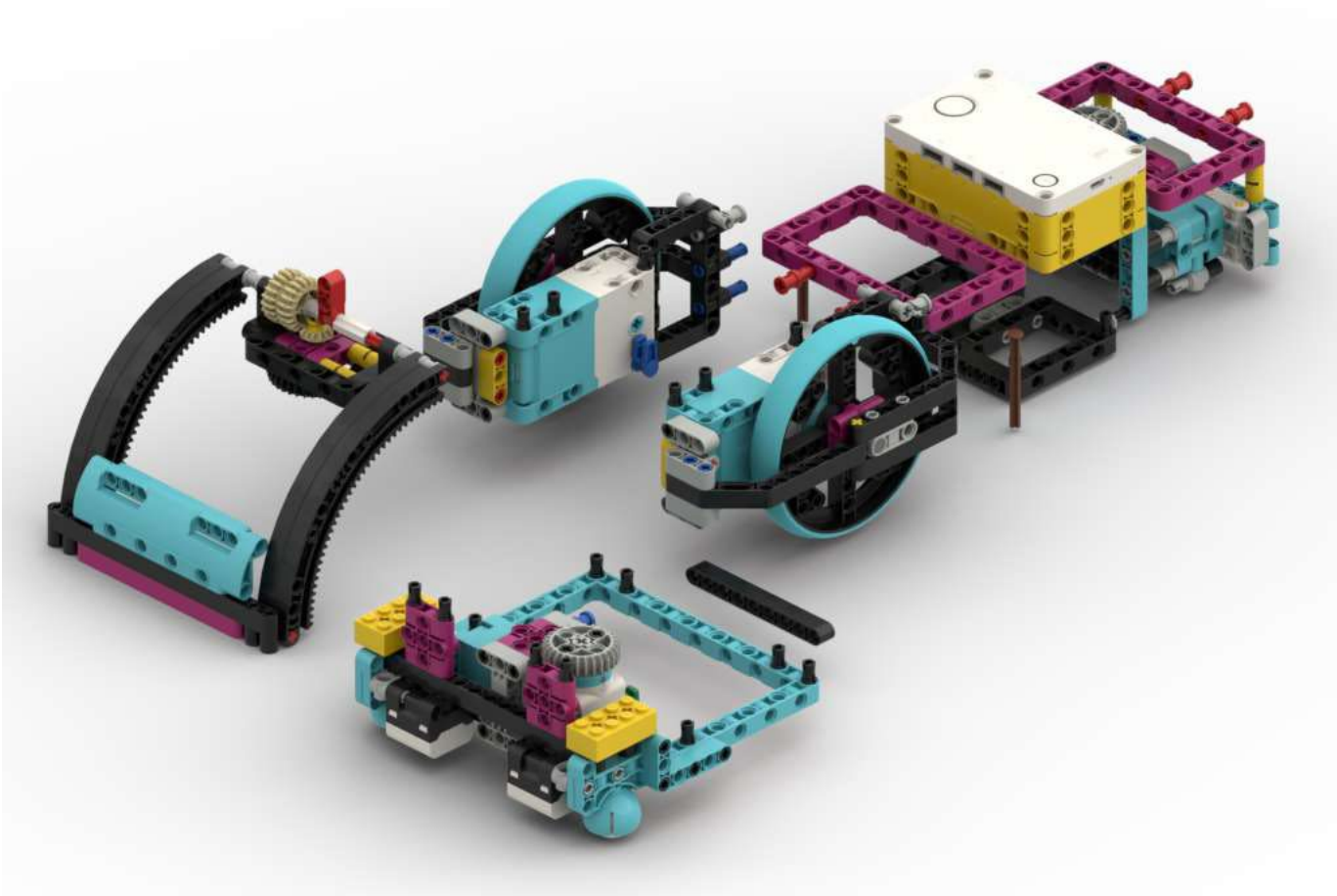

Labelled Robot

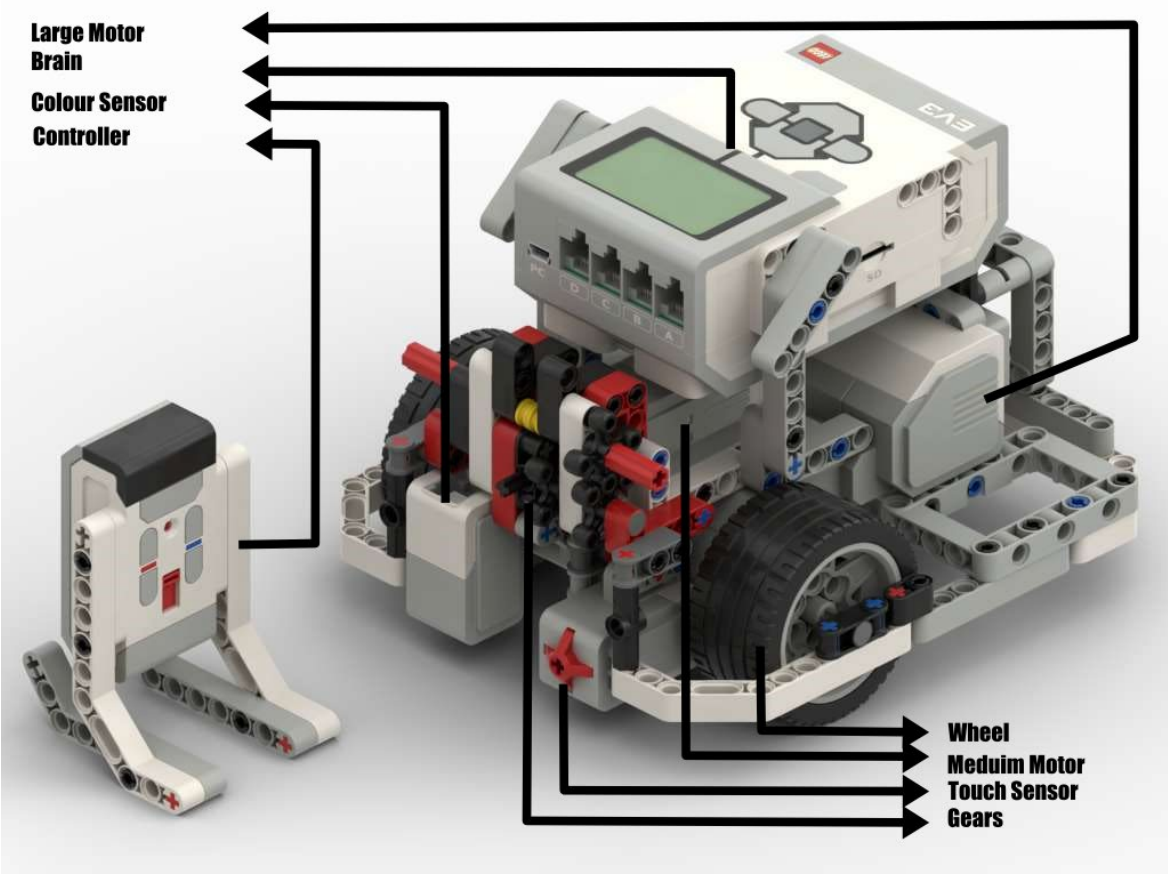

References

Ceroni, JA., and Nof, SY. 1999. Robotics Terminology. In: Nof, SY. Handbook of Industrial Robotics, Second Edition. New Jersey: John Wiley & Sons, Inc.

Department of Arts and Culture. 2013. Multilingual Natural Sciences & Technology Term List. <http://www.dac.gov.za/sites/default/files/terminology/natural-science-and-technology-term-list.pdf>

Productivity Inc. nd. Robotics & Automation. productivity.com | 763.476.8600. <https://www.productivity.com/robotic-glossary-of-terms/>

Smith, BM., Albus, JS., and Barbera, AJ. 1981. A glossary of terms for robotics. NBS Publications.

Thomson, P. 2021. An Easy-To-Understand Glossary of Common Robotics Terms. <https://learn.g2.com/robot-terms>



Define tomorrow .