

**PSYCHOLOGICAL AND SOCIAL FACTORS RELATED TO  
PHYSICAL SCIENCE ACHIEVEMENT AND ATTITUDE OF  
SECONDARY SCHOOL STUDENTS**

by

**ELIAS OUPA MASHILE**

submitted in accordance with the requirements

for the degree of

**DOCTOR OF EDUCATION**

in the subject

**PSYCHOLOGY OF EDUCATION**

at the

**UNIVERSITY OF SOUTH AFRICA**

**PROMOTER: PROF S.M. MELLET**

**JULY 1999**

Student Number: 498-410-2

I declare that **PSYCHOLOGICAL AND SOCIAL FACTORS RELATED TO PHYSICAL SCIENCE ACHIEVEMENT AND ATTITUDE OF SECONDARY SCHOOL STUDENTS** is my own work and that all the sources that I have used or quoted have been indicated and acknowledged by means of complete references.



.....  
ELIAS OUPA MASHILE

13/7/99

.....  
DATE

# ACKNOWLEDGEMENTS

It was an exceptional privilege to undertake this research under the competent guidance of my promoter, Professor S.M. Mellet. His expert advice and meticulous guidance was indispensable and his constant encouragement supported me throughout my studies (MEd and DEd).

I would also like to express my sincere gratitude to the following persons and institutions for their individual assistance and contributions:

- Ms Karlien de Beer - Unisa Library Services
- The Statistical Consultancy Services - UNISA Department of Statistics
- Mr Norman and his colleagues, Surika and Anne-Mari - UNISA Computer Services
- Prof G Bester - Faculty of Education, Unisa

Furthermore, I am indebted to my family for their understanding and patience. Without their support and encouragement, this research would have been an insurmountable quest.

A special thanks to my sister, Christina Telela, for her support and encouragement. God bless you.

The greatest praise goes to my Creator through whom I exist and to whom my greatest debt is. To God be all the glory and praise for He is Worthy of all praise.

Elias Oupa Mashile

Pretoria: July 1999

**DEDICATED TO MY WIFE, MANARE;**

**OUR THREE SONS, MAHLATSE, KHUTSO AND TUMISHANG;**

**AND MY LATE MOTHER FOR INSPIRING ME TO ACHIEVE.**

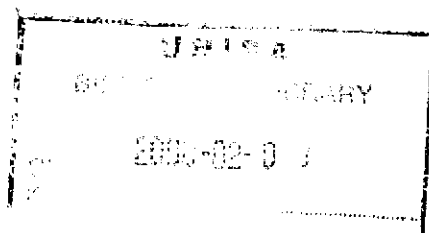

500.20712 MASH



# **PSYCHOLOGICAL AND SOCIAL FACTORS RELATED TO PHYSICAL SCIENCE ACHIEVEMENT AND ATTITUDE OF SECONDARY SCHOOL STUDENTS**

BY: Elias Oupa Mashile  
DEGREE: Doctor of Education  
SUBJECT: Psychology of Education  
UNIVERSITY: University of South Africa  
PROMOTER: Professor S.M. Mellet

## **SUMMARY**

School physical science is a prerequisite for science courses at institutions of higher education. Science graduates are an important link in a nation's scientific and technological development which often shapes a country's economic development. The purpose of this study was to investigate psychological and social factors influencing physical science achievement and attitude of black secondary school students in South Africa.

The first part of the literature study which was concerned with physical science education in South Africa revealed that few black students chose to study science after standard seven, that failure rates were high and that science education was generally in a state of crisis. The second part of the literature study identified psychological and social factors related to science achievement and attitude. These were home environment variables, teacher and school related variables, personal variables (self-concept, motivation, gender, ethnicity) and students' abilities. The third part was the construction of a Structural Equation Model (SEM) specifying the relationships among the psychological and social factors and their effects on physical science achievement and attitude.

The theoretical SEM fit the data reasonably well. The best fitting model, however, was a revised model in which several paths were constrained. The latter accounted for a substantial variance in attitude towards physical science (70.3%) and a meagre 17.7% in physical science achievement.

The variables ability, home environment and self-concept had the greatest total effects on physical science achievement. Self-concept, home environment and motivation made the greatest total contributions to physical science attitude. Teacher characteristics and school environment had non-significant effects on physical science achievement and attitude. Multiple-group structural equation modelling analyses found no significant difference in the structural parameters of boys and girls.

Theoretical and educational implications of the findings were discussed and specific recommendations for improving educational practice in general and physical science achievement and attitude in particular, were made.

## KEY TERMS

- ✓ SCIENCE ACHIEVEMENT
- ✓ SCIENCE ATTITUDE
- ✓ SCIENCE EDUCATION
- ✓ SCIENCE LITERACY
- ✓ STRUCTURAL EQUATION MODELLING
- ✓ LISREL
- ✓ PSYCHOLOGICAL FACTORS
- ✓ SOCIAL FACTORS
- ✓ SECONDARY SCHOOL STUDENTS
- ✓ CONFIRMATORY FACTOR ANALYSIS

**PSYCHOLOGICAL AND SOCIAL FACTORS RELATED TO PHYSICAL SCIENCE ACHIEVEMENT  
AND ATTITUDE OF SECONDARY SCHOOL STUDENTS**

**TABLE OF CONTENTS**

Contents	(i)
List of acronyms	(ix)
List of figures	(x)
List of tables	(xi)
References	165
Appendix A	
Appendix B	

**CONTENTS**

**CHAPTER 1**

**INTRODUCTORY ORIENTATION AND STATEMENT OF THE PROBLEM**

1.1	INTRODUCTION	1
1.2	PROBLEM ANALYSIS	2
	1.2.1 Awareness of the problem	2
	1.2.2 Demarcation of study	3
	1.2.3 Preliminary review of literature	3
1.3	AIMS OF THE RESEARCH	5
1.4	STATEMENT OF THE PROBLEM	5
1.5	RESEARCH DESIGN	5
1.6	EXPLANATION OF CORE CONCEPTS	6
	1.6.1 Physical science	6
	1.6.2 Physical science achievement	7
	1.6.3 Attitude towards physical science	7
	1.6.4 Secondary school students	7
	1.6.5 Factors (Psychological and Social)	8
1.7	THE RESEARCH PROGRAMME	8



**CHAPTER 2****PHYSICAL SCIENCE EDUCATION IN SOUTH AFRICA**

2.1	INTRODUCTION	10
2.2	THE VALUE AND ROLE OF SCIENCE EDUCATION	11
2.2.1	Science and society	11
2.2.1.1	Science literacy	11
(a)	Definitions of science literacy	11
(b)	The public understanding of science	13
(c)	Clarification of controversial issues	15
2.2.1.2	The role of institutions of learning	17
(a)	Orientation	17
(b)	Practices in the old South Africa	17
(c)	Practices in the new South Africa	20
2.2.1.3	Summary	21
2.2.2	Science and the economy	21
2.2.3	Science and technology	23
2.3	SCIENCE IN THE EDUCATION SYSTEM	26
2.3.1	Orientation	26
2.3.2	Education under the old act	26
2.3.2.1	Structure of the school system	26
2.3.2.2	The science curriculum	29
2.3.2.3	Deficiencies in the science curriculum	31
2.4	THE CRISIS IN SCIENCE EDUCATION	33
2.4.1	Teacher and teaching related problems	34

2.4.1.1	Preservice education of teachers	34
2.4.1.2	Physical science teaching	36
2.4.2	Implementation of curricula	37
2.4.3	Increased enrolments at secondary schools	39
2.4.4	School administration	40
2.4.5	Insufficient planning	40
2.5	<b>BARRIERS TO PARTICIPATION BY BLACKS</b>	42
2.5.1	Interest and enrolments	42
2.5.2	Achievement and anxiety	42
2.5.3	Personal factors	44
2.5.4	Role models	44
2.5.5	Early career aspirations	45
2.6	<b>CONCLUSION</b>	45
<b>CHAPTER 3</b>		
<b>THE THEORETICAL APPROACH TO THE STUDY OF SCIENCE ACHIEVEMENT AND ATTITUDE</b>		
3.1	<b>INTRODUCTION</b>	47
3.2	<b>STATISTICAL CONCEPTS USED IN RESEARCH REPORTS</b>	48
3.2.1	The correlation coefficient	48
3.2.1.1	The effects of curvilinearity	49
3.2.1.2	Sampling effects	50
3.2.1.3	Effects of normality	50
3.2.2	Meta-analysis	51
3.2.3	Effect sizes	51
3.3	<b>PSYCHOLOGICAL FACTORS RELATED TO SCIENCE ACHIEVEMENT AND ATTITUDE</b>	53
3.3.1	Orientation	53
3.3.2	The student's ability	53
3.3.3	The student's gender and race	55

3.3.3.1	Gender and race differences in science achievement	55
3.3.3.2	Gender and race differences in attitude towards science	57
3.3.3.3	Summary	59
3.3.4	Self-concept	59
3.3.5	Motivation	61
3.3.6	Subject preference, intentions for further study and career aspirations	63
3.3.7	Attitude towards science	65
3.3.8	Summary	67
3.4	SOCIAL FACTORS RELATED TO SCIENCE ACHIEVEMENT AND ATTITUDE	67
3.4.1	Orientation	67
3.4.2	The family	68
3.4.2.1	The home (family) environment	68
3.4.2.2	Parental socioeconomic status	69
3.4.2.3	Parenting styles	70
3.4.2.4	Parental beliefs	70
3.4.2.5	Summary	71
3.4.3	The school	71
3.4.3.1	The school and science achievement	71
3.4.3.2	The school and attitude towards science	74
3.4.3.3	Summary	75
3.5	CONCLUSION	76

## CHAPTER 4

### THE METHODOLOGICAL APPROACH TO THE STUDY OF SCIENCE ACHIEVEMENT AND ATTITUDE

4.1	INTRODUCTION	78
4.2	THINKING IN TERMS OF MODELS	79
4.3	STRUCTURAL EQUATION MODELLING	81

4.3.1	Causality	81
4.3.2	Analysis of non-experimental data	82
4.3.3	The measurement model	82
4.3.4	The structural equation model	85
4.4	REVIEW OF CAUSAL MODELS IN SCIENCE ACHIEVEMENT AND ATTITUDE	89
4.4.1	The home variables-science achievement path	92
4.4.2	The home-personal-ability-achievement path	93
4.4.3	The home variables-attitude towards science path	95
4.4.4	The personal variables-attitude towards science path	96
4.4.5	The personal variables-achievement path	98
4.4.6	The school-achievement path	99
4.4.7	The school-attitude towards science path	101
4.4.8	The attitude towards science-achievement path	103
4.5	THE PSYCHOLOGICAL AND SOCIAL SEM OF SCIENCE ACHIEVEMENT AND ATTITUDE	104
4.6	CONCLUSION	106

## CHAPTER 5

### THE EMPIRICAL INVESTIGATION: PLANNING, METHOD, EXECUTION AND RESULTS

5.1	INTRODUCTION	108
5.2	OBJECTIVES OF THE EMPIRICAL INVESTIGATION	108
5.3	PLANNING OF THE EMPIRICAL INVESTIGATION	109
5.3.1	The research group	109
5.3.2	Permission to use the schools for the investigation	111
5.3.3	Instruments	111
5.3.3.1	Operational variables of the home latent factor	112
	(a) Socioeconomic background	112
	(b) Parental involvement and attitude	112
5.3.3.2	Operational variables of the personal latent factor	113

(a)	Motivation to learn physical science	113
(b)	Physical science self-concept	113
5.3.3.3	Operational variables of the school latent factor	114
(a)	Teacher characteristics	114
(b)	Instructional time	114
(c)	School environment	114
5.3.3.4	Operational variables of the attitude towards physical science latent factor	115
(a)	General attitude towards physical science	115
(b)	Usefulness of physical science	115
(c)	Attitude towards physical science careers and courses	115
(d)	Attitude towards practical work in physical science	115
5.3.3.5	Operational variables of the ability latent factor	115
5.3.3.6	The achievement factor	116
5.3.3.7	Construction of items	116
5.3.4	The questionnaire	116
5.3.4.1	The properties of an effective questionnaire	117
5.3.4.2	Format of the questionnaire	117
5.3.4.3	Instructions for the completion of the questionnaire	120
5.3.4.4	Preliminary evaluation of the questionnaire	120
5.4	METHOD	121
5.4.1	Statistical techniques	121
5.4.1.1	Item analysis	121
5.4.1.2	Factor analysis	121
5.4.1.3	Testing of hypotheses	122
5.4.2	Completion and treatment of data	122

<b>5.5 RESULTS</b>	<b>123</b>
5.5.1 Descriptive statistics	123
5.5.2 Preliminary tests of measurement models	123
5.5.3 Estimation of the global measurement model	134
5.5.4 Estimation of the structural model	136
5.5.5 Effects on physical science achievement	140
5.5.5.1 Direct effects	140
5.5.5.2 Indirect and total effects	142
5.5.6 Effects on physical science attitude	142
5.5.7 Effects of gender on physical science achievement and attitude	143
<b>5.6 REMARKS</b>	<b>144</b>

## **CHAPTER 6**

### **FINDINGS, RECOMMENDATIONS AND CONCLUDING REMARKS**

<b>6.1 INTRODUCTION</b>	<b>145</b>
<b>6.2 FINDINGS AND CONCLUSIONS FROM THE LITERATURE STUDY</b>	<b>146</b>
6.2.1 Objectives of the literature study	146
6.2.2 Physical science education in South Africa	146
6.2.2.1 The value and role of science education	146
6.2.2.2 The quality of science education	147
6.2.2.3 The crisis in science education	147
6.2.3 Determinants of science achievement and attitude: theoretical approach	148
6.2.3.1 Psychological factors related to science achievement and attitude	148
(a) The student's ability	148
(b) The student's gender	148
(c) Self-concept	148
(d) Motivation	148

(e)	Attitude towards science	149
(f)	Subject preference, intentions for further study and career aspirations	149
6.2.3.2	Social factors related to science achievement and attitude	149
(a)	Parental socioeconomic status	149
(b)	The home environment	149
(c)	The school and science achievement	150
(d)	The school and attitude towards science	150
6.2.4	Determinants of science achievement and attitude: the methodological approach	150
6.3	<b>FINDINGS AND CONCLUSIONS FROM THE EMPIRICAL STUDY</b>	151
6.3.1	The objectives of the empirical investigation	151
6.3.2	Physical science achievement and attitude of urban black students	152
6.3.3	The factorial structure of the measurement model	152
6.3.4	Correlations amongst the latent factors	153
6.3.5	Estimation of the structural model	153
6.4	<b>RECOMMENDATIONS AND IMPLICATIONS</b>	155
6.4.1	Significant other - student relationships	155
6.4.1.1	Parent - student relationships	155
6.4.1.2	Teacher - student relationships	156
6.4.2	Quality of science education	157
6.4.3	Affective factors in science education	160
6.5	<b>LIMITATIONS OF THIS STUDY</b>	161
6.6	<b>SUGGESTIONS FOR FUTURE RESEARCH</b>	163
6.7	<b>CLOSING REMARKS</b>	163

**LIST OF ACRONYMS**

ANC	:	African National Congress
SEM	:	Structural Equation Model
STS	:	Science, Technology, and Society
DET	:	Department of Education and Training
SEP	:	Science Education Project
NGO	:	Non-Government Organisation
SAT	:	Scholastic Aptitude Test
NCHE	:	National Commission on Higher Education
RSA	:	Republic of South Africa
DNE	:	Department of National Education
NEPI	:	National Education Policy Investigation
CHED	:	Committee of Heads of Education Departments
JMB	:	Joint Matriculation Board
PTD	:	Primary Teachers' Diploma
STD	:	Senior Teachers' Diploma
SSTD	:	Senior Secondary Teachers' Diploma
SED	:	Secondary Education Diploma
HED	:	Higher Education Diploma
LISREL	:	Linear Structural Relationships
SES	:	Socio-Economic Status
GFI	:	Goodness of Fit Index
AGFI	:	Adjusted Goodness of Fit Index
ELRC	:	Education Labour Relations Council
SAQA	:	South African Qualifications Authority
NQF	:	National Qualifications Authority
ETQA	:	Education and Training Quality Assurance
INSET	:	In-Service Education and Training
CPD	:	Continuous Professional Development
SACE	:	South African Council of Educators



## LIST OF FIGURES

Figure 2.1	Retention rates in white schools	27
Figure 2.2	Retention rates in black schools	28
Figure 3.1	A hypothetical association between two variables	49
Figure 4.1	A simple arrow diagram indicating how education expenditure might affect student performance	79
Figure 4.2	A more complex arrow diagram indicating how education expenditures and family environment might affect student performance	80
Figure 4.3	The congeneric measurement model	84
Figure 4.4	A path diagram for a hypothetical model	87
Figure 4.5	Path diagram for performance in science	89
Figure 4.6	The structural equation model of academic achievement	91
Figure 4.7	The theoretical SEM of science achievement and attitude (psychological and social factors)	105
Figure 5.1	A conceptual model showing psychological and social factors related to physical science achievement and attitude	118
Figure 5.2	Measurement model of the home factor	127
Figure 5.3	Measurement model of the ability factor	128
Figure 5.4	Measurement model of the attitude factor	129
Figure 5.5	Measurement model of the motivation factor	130
Figure 5.6	Measurement model of the self-concept factor	131
Figure 5.7	Measurement model of the teacher characteristics factor	132
Figure 5.8	Measurement model of the school environment factor	133
Figure 5.9	Theoretical structural model ( $M_t$ )	137
Figure 5.10	Constrained structural model ( $M_c$ )	139

## LIST OF TABLES

Table 2.1	Senior certificate matriculation results, 1989	18
Table 2.2	School science and mathematics subjects and availability of choice	29
Table 2.3	Typical subject combination for a senior secondary level science stream in black schools	30
Table 2.4	A typical timetable for a senior secondary school class	31
Table 2.5	Qualifications of black school teachers in 1991	35
Table 4.1	Summary of the relationship between home variables and science achievement	93
Table 4.2	Summary of the relationship between home variables and ability variables	94
Table 4.3	Summary of the relationship between home variables and attitude toward science	96
Table 4.4	Summary of the relationship between personal variables and attitude towards science	97
Table 4.5	Summary of the relationship between personal variables and science achievement	99
Table 4.6	Summary of the relationship between school variables and science achievement	100
Table 4.7	Summary of the relationship between school variables and attitude toward science	102
Table 4.8	Summary of the relationship between attitude towards science and science achievement	103
Table 5.1	Distribution of subjects according to school and grade level	109
Table 5.2	Distribution of the subjects according to grade level and gender	109
Table 5.3	Age distribution of the subjects	110
Table 5.4	Distribution of subjects according to ethnicity	110
Table 5.5	Format of the items used in the questionnaire	119
Table 5.6	Descriptive statistics of observable variables	124
Table 5.7	Correlations among observed variables	125
Table 5.8	Confirmatory factor analysis for measurement model evaluation: model fits and loadings for the completely standardised solution	135
Table 5.9	Correlations between the latent factors	136
Table 5.10	Values of standardised parameter estimates and test statistics (t) for the theoretical model	138
Table 5.11	Values of standardised parameter estimates and test statistics (t) for the unconstrained model	141
Table 5.12	Direct, indirect and total effects on physical science achievement	142

Table 5.13	Direct, indirect and total effects on physical science attitude	143
Table 6.1	Goodness-of-fit indices of models tested	154

## CHAPTER 1

### INTRODUCTORY ORIENTATION AND STATEMENT OF THE PROBLEM

#### 1.1 INTRODUCTION

It is generally accepted that physical science teaching is important for technological development. The understanding of scientific principles has always been considered necessary for understanding and mastery of Technology. Nowadays, technological development is increasingly dependent upon scientific understanding. As such formal qualifications that advance technological development require knowledge of school physical science. For example, school physical science is a prerequisite in professional qualifications such as engineering, medicine and other sciences. Technical subjects also rely heavily on physical science knowledge. In other words, students who want to pursue careers in the technical fields at technical colleges need to have some knowledge of school physical science. In this regard school physical science opens the door to a diverse number of careers which an individual can follow.

This is important for all concerned in the education of children to note since there is a dire need in the economy for a skilled work force in the areas of Science and Technology. It is also important to note that the majority of unemployed people are neither skilled nor have formal knowledge in these fields.

Another aspect in the case for school physical science is that the problem solving methods acquired whilst studying the subject, if properly taught, can be applied in many situations outside formal education. That is, knowledge gained from physical science can be used by individuals in improving their own lives and also in coping with an increasingly technological world. In this information technology revolution we are experiencing, individuals need to know how to analyse, process and interpret information. All these skills form part of the process nature of school physical science. A detailed discussion of the importance of science (physical science) education is presented in chapter two.

The problem, however, is that few students opt to study physical science at senior secondary and tertiary level. This is further complicated by the fact that most physical science students perform poorly in the matriculation examination, particularly black students. As such very few students are able to take science subjects at tertiary level. The effect this has on technological development and on economic development in general, is immense. There is thus a need for mechanisms to enhance physical science achievement and of making the subject popular amongst students. This study was therefore initiated to investigate psychological and social factors influencing physical science achievement and attitude. The study was limited to black students in urban areas of the Gauteng province, South Africa.

## 1.2 PROBLEM ANALYSIS

### 1.2.1 AWARENESS OF THE PROBLEM

The onset of South Africa's transition to democracy in and around 1990 saw an expansion of the schooling system, especially in the black community. From an analysis of demographic trends, Christie (1992:40-41) postulates that the expansion will continue for several years to come. The National Commission on Higher Education (NCHE 1996:61), predicts that secondary school pupils will rise from 3,5 million to 5,5 million over the next decade.

From a literacy point of view the increase in student numbers is welcome. The problem, however, is that a large number of matriculants do not possess the necessary scientific and technical skills required to sustain a growing economy. According to the Carnegie Commission on Science, Technology, and Government (1991:15), a nation's ability to compete technologically requires not only an adequate supply of scientific and technical professionals but a work force able to solve problems and use the tools of a knowledge-intensive economy. Consequently, all young people must be given an opportunity to become competent in mathematics and science.

An analysis carried out by the NCHE (1996:34) indicates that South Africa's output (number of graduates) in science, engineering and technology is low by international standards. Blacks were found to be conspicuously under-represented, with not less than 80% of the personnel in science, engineering and technology being white. The apartheid schooling system, avers the commission, effectively restricted black students from entering higher education and particularly disciplines in the natural sciences. This is evidenced by the fact that one black school pupil to every sixty white school pupils obtains a matriculation exemption in physical science and mathematics. Unfortunately the situation still prevails in the post-apartheid dispensation. For example, an analysis of the 1995 matric results shows the following pass figures:

House of Assembly	- 96%
House of Delegates	- 93%
House of Representatives	- 87%
Department of Education and Training (DET)	-48%

When we consider that approximately 70% of matric students come from the erstwhile DET, a department with predominantly black students, and that only a small fraction of the meagre 48% pass rate acquired a matriculation exemption, let alone in physical science and mathematics, a grossly inadequate human resource picture emerges (Mabandla 1995:6).

Given such a state of affairs, considerable research is sought that will identify factors that could possibly enhance black students' achievement in science, especially those that are alterable by policy intervention. Programmes that will not only draw large numbers of students but that will also increase the level of achievement of students in the sciences are urgently required. This is critical for the development of the South African economy.

A wide spectrum of factors which influence physical science achievement and attitude have been identified in the literature. Which factors, however, could possibly enhance physical science achievement and attitude and thus enhance the popularity of physical science as a school subject among black secondary school students? To date, there has been no attempt to investigate the mutual influence of psychological and social factors on science achievement and attitude among black South African students. Research studies in this field, for example Schibeci and Riley (1986), Tamir (1989), Rennie and Punch (1991), Reynolds and Walberg (1992) and House (1993) are based on foreign education systems which have different socio-cultural environments. Consequently, a theoretical framework is required that will direct research investigations for the South African education system in the field of science achievement and attitude. It is within this context that this study was initiated.

### **1.2.2 DEMARCATION OF STUDY**

Science achievement and attitude are influenced by a multiplicity of factors. These factors interact with each other and jointly influence science achievement and attitude. One such set of factors is "political factors". The influence of politics on the South African education system is however extensively documented (Alexander 1990; Dostal 1990; Samuel 1990; Moller 1991; Christie 1992; Southern African conference on relevant education 1992; Mashile 1995; NCHE 1996). The problems directly associated with apartheid education (for example lack of physical facilities, socio-economic status of schools and/or students, financing of education, quality of teachers, and the like) are rooted in the education system and forms part of its socio-cultural environment. In other words, an analysis of social factors influencing science achievement and attitude incorporates the effects of political factors. Consequently, current problems arising from the old dispensation will be mentioned only to give clarity to the situation or problem being described. The focus of this study will be on identifying psychological and social factors that are related to physical science achievement and attitude.

### **1.2.3 PRELIMINARY REVIEW OF LITERATURE**

Physical science and Biology make up the subject General Science in South African schools. The latter is compulsory for all students in standards six and seven (grades eight and nine, respectively). At the end of standard seven, pupils are required to make a choice. They can choose to take physical science and mathematics or to take either commercial subjects or human science subjects.

It is during these junior secondary school years (standards five to seven), that attitudes are formed that influence physical science course selections in senior secondary school (standards eight to ten) and tertiary institutions (Tocci & Engelhard 1991:280). Course selections will eventually affect career selections. If few students select physical science and mathematics at school, the country will produce few tertiary education graduates in the essential fields of natural sciences, engineering and computer sciences. Affective factors (attitude) therefore play a crucial role in developing a disposition to study and take physical science in higher standards and at tertiary institutions.

People's attitudes are influenced by direct experiences with the attitude object (for example science achievement) and by interactions with significant others (Tocci & Engelhard 1991:280). We can then deduce that the child's cognitive ability in physical science, his affective experiences with the subject and teachers, his encouragement from parents and friends, *etcetera*, will influence his attitude towards the subject and consequently his choice of physical science in standard eight and higher. In other words, psychological as well as social factors have an influence on students' attitudes toward physical science.

On the other hand, educational productivity research, the study of the factors that affect student achievement, has been and will continue to be a major focus of research in science education (Menis & Fraser 1992:131). This is because influences on student achievement are many and varied. Research studies indicate that psychological factors (student learning, attitudes, *etcetera*) as well as social factors (family, socio-economic status, *etcetera*) have an influence on science achievement (Schibeci & Riley 1986:177; House 1993:155).

From the preceding paragraphs it appears that attitudes toward science and science achievement are influenced by almost similar psychological and social factors. This makes sense if one recognizes that attitudes toward science and science achievement are both learning outcomes. The two phenomena can as a result be studied concurrently in order to identify their interactional effects. To accomplish this goal, the results of the literature study were developed into a theoretical structural equation model.

The theoretical structural equation model specify the relationships between the independent variables (that is, psychological and social factors identified in the literature study) and the dependent variables (physical science achievement and attitude). The model also makes explicit the relationships among the independent variables. Each relationship in the model represent a hypothesis that is tested by estimating the magnitude of that relationship.

To develop the theoretically constructed model into a valid theory, the assertions of the theoretical structural equation model were tested by data obtained from secondary school students. A statistical tool used to test the theoretical structural equation model is called Structural Equation Modelling (SEM). According to Reynolds and Walberg (1991:98), structural equation modelling is necessary and is

recommended for testing theories and models since it provides for reverse and joint effects; it takes account of measurement error, relationships among predictor variables and unequal interval scaling of independent and dependent variables. Computer software packages (LISREL IV to VII) have been developed and are available for use in structural equation modelling. LISREL is an acronym for Linear Structural Relationships. A discussion of structural equation modelling and LISREL is given in chapters four and five.

### **1.3 AIMS OF THE RESEARCH**

The aim underlying this study is the identification of psychological and social factors influencing physical science achievement and attitude of black secondary school students in South Africa. It encompasses the building up of a model that can be used with some confidence to show the effects of each factor on physical science achievement and attitude. It also implies the need to identify and evaluate instruments that could possibly be used, or modified and developed for use, in future research into physical science achievement and attitude of South African black secondary school students. Lastly, it encompasses the need for developing mechanisms of enhancing physical science achievement and attitudes toward physical science of black secondary school students.

### **1.4 STATEMENT OF THE PROBLEM**

From the analysis of the problem and the aims of this investigation, the following research questions are posited:

- Which psychological and social factors are related to physical science achievement and attitude of black secondary school students?
- Does the theoretical model proposed for the structure of psychological and social factors influencing science achievement and attitude fits empirical data obtained from secondary school students?

### **1.5 RESEARCH DESIGN**

To fulfil the aims of this study, a literature review on psychological and social factors influencing science achievement and attitude was undertaken. The outcome was used to build a theoretical structural equation model depicting the spatial relationships among the factors. Measuring instruments appropriate to the theoretical structural equation model were developed and administered to secondary school children in the black townships of Johannesburg, Gauteng. The townships are metropolitan in



nature. There are approximately sixty five schools in the region hence participant schools and students were determined randomly. With the aid of SEM, the theoretical structural equation model was tested using empirical data collected from standard seven and eight physical science students.

The rationale for testing standard seven and eight students centres around the following. Firstly, it is at this stage where standard seven students have to choose to continue studying physical science or to discontinue their studies in this field. Their attitudes toward physical science, then, influence their choice of the subject in standard eight. Secondly, standard eight students who chose to continue studying physical science usually continue with the subject up to standard ten. Their experiences of the subject are thus pivotal for further studies in this field.

A plausible, revised structural equation model that best describes the data was estimated for use in future research investigations. Finally, mechanisms that could enhance physical science achievement and attitude amongst urban secondary school students were discussed.

## **1.6 EXPLANATION OF CORE CONCEPTS**

In the light of the problem formulated and the aims of this study, it is necessary to analyse some terms and concepts for the purposes of clarity and to avoid ambiguity in communication.

### **1.6.1 PHYSICAL SCIENCE**

Physical science is defined in the Encyclopaedia Britannica (Goetz 1986:841) as the systematic study of the inorganic world. Physical science is ordinarily thought of as consisting of four broad areas: astronomy, physics, chemistry and the earth sciences. Each of these is in turn divided into fields and sub-fields. The school subject physical science, however, consists only of physics and chemistry.

Physics is the basic physical science. It deals with the structure and behaviour of individual atoms and their components, as well as with the different forces of nature and their relationships. It also is concerned with the physical properties of matter and with such phenomena as electricity and magnetism. Its goal is the formulation of comprehensive principles that summarize disparate phenomena in the most general way possible and that are expressed with economy and precision in the language of mathematics. The principal subject areas of physics are mechanics, gravitation, thermodynamics and heat, electricity and magnetism, optics, atomic and chemical physics, condensed-matter physics, nuclear physics, particle physics, quantum mechanics, relativistic mechanics, conservation laws and symmetry, and fundamental fields and forces.

School physics, however, excludes subject areas such as quantum mechanics, relativistic mechanics and symmetry. The other subject areas are taught at a fairly elementary level.

Chemistry focuses on the properties and reactions of molecules. Broadly speaking, it tends to concentrate on the specific properties of different elements and compounds, as opposed to physics which is chiefly concerned with the general properties of matter as a whole. The principal divisions of chemistry are analytical chemistry, inorganic chemistry, organic chemistry, biochemistry, polymer chemistry, physical chemistry and industrial chemistry. Biochemistry, polymer chemistry and industrial chemistry are excluded in school chemistry syllabuses.

### **1.6.2 PHYSICAL SCIENCE ACHIEVEMENT**

The term achievement is used here to denote the degree of success, accomplishment or attainment by students in the school subject of physical science. It reflects the intellectual and physical activity, effort, skill and perseverance expended by students in the pursuit of their desired goals or desired levels of performance in this subject. Since examination results (half yearly and end of year) are held in high regard by most students, they will be used as indicators of students' achievement in physical science.

### **1.6.3 ATTITUDE TOWARDS PHYSICAL SCIENCE**

Attitude is a complex psychological concept that is not directly observable. Numerous definitions have been advanced (Mashile 1995:56-60) but one that has scope for psychological and social attributes is that of Anderson (1985:354). He states that "attitude can be considered a moderately intense emotion that prepares or predisposes an individual to respond consistently in a favourable or unfavourable manner when confronted with a particular object."

Attitude towards physical science is therefore the psychological inclination or tendency of a student to react to all aspects of the subject, including science instruction, science careers, interest in science outside lessons and social implications of science.

### **1.6.4 SECONDARY SCHOOL STUDENTS**

After primary school years the child, according to Van den Aardweg and Van den Aardweg (1993:212), enters the secondary school. Theoretically, the Junior Secondary School usually runs from standard five to standard seven and the Senior Secondary School from standard eight to standard ten. In practice, however, the secondary school caters for standards six to ten. The children in secondary school are approximately between thirteen and eighteen years of age. In black schools, however, the upper limit

can be considerably higher. It is possible to find students in the age group of twenty five years to thirty years in any of the secondary school standards.

Secondary school students are often regarded as adolescents. "The term 'adolescence' derives from the Latin verb *adolescere*, meaning 'to grow up' or 'to grow to adulthood', thus referring to a development phase in the human life cycle that intervenes between childhood and adulthood" (Gouws & Kruger 1994:3). During this period the adolescent strives towards achieving the attitudes and beliefs, as well as developing skills, needed for survival and for effective participation in society. As noted earlier, some of the black secondary school students have already passed the stage of adolescence and can actually be referred to rather as youth.

### **1.6.5 FACTORS (PSYCHOLOGICAL AND SOCIAL)**

The Oxford dictionary (Bradford 1989:266) explains a factor as a circumstance contributing to a result. The Heritage dictionary (Morris 1973:469) describes a factor as something that actively contributes to an accomplishment, result or process. These explanations indicate that a factor has an influencing nature. That is, the process, result or accomplishment under investigation is influenced by one or more factors. Intelligence, for example, influence scholastic achievement and hence it is said to be a factor related to scholastic achievement.

The processes investigated in this study are physical science achievement and attitude. The study aims at identifying psychological and social factors related to these processes. By psychological factors is meant all factors that are of a psychological nature, for example personal characteristics, motivation, intelligence, gender, ethnicity, and the like. By social factors is meant all factors that contribute to the socialization of an individual, for example, the family, the school, peer group, formal organizations, and the like.

## **1.7 THE RESEARCH PROGRAMME**

This study comprises the following chapters:

### *Chapter 1*

This chapter deals with an introductory orientation to the investigation. The research problem and its importance, the aims and design of the research, and a preliminary literature review are also contained in this chapter.

## *Chapter 2*

Chapter two is devoted to physical science education in South African schools. The nature, role and value of physical science, the place of physical science in the national curriculum, and the state of physical science education in South Africa are investigated.

## *Chapter 3*

Chapter three focus on the review of the literature with regard to psychological and social factors related to science achievement and attitude. Previous research with a theoretical approach to the study of physical science achievement and attitude is reported in this chapter. This information is crucial and is needed in the construction of the theoretical structural equation model in chapter four.

## *Chapter 4*

This chapter focus on research using the methodological approach to the study of physical science achievement and attitude. A general discussion on the construction of structural equation models is followed by the construction of a psychological and social theoretical structural equation model of physical science achievement and attitude. The latter was tested empirically by using data obtained from black secondary school students. A *good fit* indicates the validity of the theoretical structural equation model.

## *Chapter 5*

Chapter five deals with the planning, method, execution and results of the empirical investigation. The instruments, subjects, statistical tools and procedures that are followed in this study are described in this chapter, followed by the results of the empirical investigation and an interpretation of the findings.

## *Chapter 6*

The most important findings and conclusions, recommendations, limitations of the study and suggestions for future research are presented in chapter six.

## CHAPTER 2

### PHYSICAL SCIENCE EDUCATION IN SOUTH AFRICA

All young people, including the non-university bound, can and should be competent in science and mathematics; in particular, efforts should be made to draw in women and black men. The fallacy that maths and science ability is innate, and that many or most young people cannot learn mathematics and science, though disproved by sound research, persists in the minds of both parents and educators. This perverse idea becomes self-fulfilling when poor academic performance is blamed on the children instead of their parents, their schools, and their communities. The result is the exclusion of a large proportion of children from the maths/science talent pool (Carnegie Commission on Science, Technology and Government 1991:24).

#### 2.1 INTRODUCTION

Family variables and non school factors have an influence on students' conceptualization of science and scientists. Students form opinions and learn about science and scientists from families and friends, from the media, and from places such as science museums. An analysis of factors influencing physical science education will therefore draw on these non school factors.

It is largely schools, however, through preparatory courses in physical science, teaching practices and certification that determine how many young people will prepare sufficiently well for science careers. Schools ought to provide the widest possible opportunities, and the best possible educational foundations for the study of physical science. This is important when viewed in the light that only a small minority of determined students can triumph over poor teaching and inadequate course offerings. How effective South African schools meet this obligation will be investigated in this study.

Of particular concern is the low participation rate in science courses of black students who, as such, represent a large reservoir of untapped talent. Blacks make up a large proportion of the school going population in South Africa, and therefore schools need to identify and motivate these youngsters to pursue studies and careers in science. Consequently, factors that draw black students away from science courses will also be investigated in this study.

Finally, several other issues of concern will be discussed, including the quality of science education, the value and role of science, and the crisis in South African science education.

Before giving an exposition on the above issues, the researcher wants to give the following note of caution. Most of the issues raised in this chapter may be described as the negative consequences of *segregated/apartheid education* in South Africa. Since the legacy of apartheid education is still manifest,

this investigation primarily seeks to address these issues. It is important, however, to note that this emphasis must not be taken to imply that the South African education system has no merits or positive characteristics. The aim of focussing on the negative aspects was to try to get to the core of possible causal factors, which could, once uncovered, guide policy makers in taking corrective steps. In concurrence with the NCHE (1996:28), an acknowledgement is made that South Africa has achieved by a large measure, the most developed and well-resourced system of education and training in Africa. Of importance is the fact that since 1990, South Africans have shown a willingness to confront social, economic and political deficiencies and embarked on a programme of reconstruction and development.

## **2.2 THE VALUE AND ROLE OF SCIENCE EDUCATION**

Science education is an important means to economic (Zymelman 1990:1), scientific and technological development (Ogunniyi 1995:95). Just before its independence in 1994, the importance of *science for all* gained momentum among South Africans. This is evident from the resolutions and communiques made at the end of conferences, workshops, symposia and commission reports since 1990 (CHED 1991a; CHED 1991b; NEPI 1992a, b, c; NCHE 1996; *etcetera*). Why was science education given this impetus? Several reasons have been advanced, including, among others, the contribution that science makes in society, the economy, and technological innovations. An exposition on these reasons is given in the following sections.

### **2.2.1 SCIENCE AND SOCIETY**

#### **2.2.1.1 SCIENCE LITERACY**

The importance of science education stems from its ability to inculcate *scientific literacy* to many people in a given society. According to Hodson and Reid (in Jenkins 1993:232), the principal aim of school science education should be the *scientific literacy* of all pupils, irrespective of their different interests, experiences and abilities. "The importance of a scientific and technologically literate population is being emphasized in all countries, since it is recognized that specialist scientists and technologists cannot operate without a knowledgeable supporting society" (Harlen 1993:126). Furthermore, scientific and technologically literate individuals play a crucial role in a democratic society (Cheek 1992:21).

#### **(a) DEFINITIONS OF SCIENCE LITERACY**

Defining scientific literacy, however, is not an easy task. Many definitions have been given throughout the centuries. Historically, science developed from a monolithic natural science, which subsumed all disciplines and specialities, to a highly specialized and complicated enterprise. With specialization, communication among scientists became much more of an esoteric process that was hidden from the

public. Scientists grouped themselves into *professional scientific societies* and the results of their research were conveyed through journals. The writing in these journals is technical, often mathematical, and aimed at an audience of specialists, rather than a general, educated public (Sapp 1992:23). The public was therefore divorced from science and its phenomena. This vacuum was naturally filled by misconceptions and superstitions about scientific and technological innovation. Such misconceptions, however, impede scientific and technological innovations. To correct this, efforts were made and are still being made to popularize science among the public, that is, to increase science literacy.

In a review of definitions of science literacy, Sapp (1992:25-27) notes the following:

- (i) Science literacy is much less a measure of technical knowledge than of science awareness. Some basic knowledge of fundamental scientific and technical concepts is characteristic of the scientifically literate person, but more vital is an awareness of how science affects our lives, an understanding of scientific methodology, and an ability to obtain and use information about science.
- (ii) Science literacy also has an essentially participative and democratic aspect. A scientifically literate person is one who is an active and effective citizen.
- (iii) Science literacy can be best defined by the attributes and attitudes of those who possess it. It is cultivated rather than learned.

Most definitions of science literacy are lengthy and multifaceted. According to Shortland (in Sapp 1992:26), science literacy has the following components:

- (i) An appreciation of the nature and aims of science and technology, including their historical origins and the epistemological and practical values that they embody.
- (ii) A knowledge of the way in which science and technology actually work, including the funding of research, the conventions of scientific practice, and the application of new discoveries.
- (iii) A grasp of how to interpret numerical data, especially relating to probability and statistics.
- (iv) A general grounding in selected areas of science, technology and society, including the role of scientists and technicians as experts in society.
- (v) An ability to update and acquire new scientific information in the future.

Splittgerber (in Cheek 1992:23), on the other hand, believes a scientifically literate person is one who:

- (i) knows how to find information on science-related social issues;
- (ii) is an expert in dissecting the technological, political, and economic aspects of Science, Technology, and Society (STS) issues; and
- (iii) has the ability to make wise decisions.

Sapp (1992) argues that science literacy is built on a foundation of information and is the result of successful, specialized information-seeking behaviour. Based on this premise he defines science literacy as "an active understanding of scientific methods and of the social and economic roles of science as they are conveyed through various media and is thus built on an ability to acquire, update, and use relevant information about science" (Sapp 1992:25).

It can be concluded, then, that a science literate person is one who can make significant contributions in societal issues such as public policy, decision-making, *et cetera*; and that a society with a limited number of such individuals is unlikely to be competitive in the high technological era of the twentieth century.

## **(b) THE PUBLIC UNDERSTANDING OF SCIENCE**

Science literacy has two distinct dimensions (Sapp 1992:21). The first relates to education, in which the concern is the crisis in science education (see section 2.4). The second dimension, which is discussed below, reflects the problems that occur when scientifically undereducated children become adults.

It is generally agreed that science and technology are important for society and thus need to be taught in public schools and other institutions of higher education. A characteristic view is that of Millar and Driver (1987:58) quoted below.

It is not only on aesthetic grounds that a case is made for giving pupils an understanding of the nature of the scientific enterprise. Just as personal knowledge in science empowers pupils to act in their everyday lives, so a critical appreciation of the way scientists work empowers them, as future citizens in a participatory democracy, to query, question and seek alternative views on scientific and technological decisions that affect their lives. Interpreted in this way, science in schools has an enabling rather than an alienating function and has a critical role to play in a liberal education.

Scientific literacy is therefore a major force in our everyday lives. It helps structure our personal and working relationships and offer new ways of understanding everyday reality. In this regard, many



governments, institutes and organizations have pleaded for scientific literacy for all members of society. In their 1985 report, for example, the British Royal Society (in Irwin 1995:12-13), suggests that:

Better public understanding of science can be a major element in promoting national prosperity, in raising the quality of public and private decision making and in enriching the life of the individual . . . Improving the public understanding of science is an investment in the future, not a luxury to be indulged in if and when resources allow.

The report goes on to cite a number of specific areas where an *improved understanding* of science would be of personal and national value:

- (i) in terms of *national prosperity*, a better informed citizenry could appreciate the opportunities offered by new technologies and could provide a better trained workforce;
- (ii) in terms of *economic performance*, wider scientific awareness would reduce hostility, or even indifference to science and technology and so aid in the rapid innovation of such product and process changes. There would also be a considerable competitive advantage if those in positions of responsibility were better informed;
- (iii) in terms of *public policy*, science and technology should be major considerations - for the Royal Society there is a strong case that these decisions would be improved by better understanding;
- (iv) in terms of *personal decisions*, for example regarding diet, smoking, vaccination safety - an uninformed public is very vulnerable to misleading ideas;
- (v) in terms of *everyday life*, a basic scientific literacy is needed just to understand what goes on around us (for example, how a ball point pen or a television functions);
- (vi) in terms of *risk and uncertainty* (for example, concerning nuclear power or seat-belt wear), it is important that the public have a better appreciation of the nature of risks and of how to interpret and balance them: once again it must be argued that better understanding fosters better public and personal decisions;
- (vii) in terms of *contemporary thought and culture*, any citizen without an understanding of science is cut off from the richness of this important area of human enquiry and discovery.

Cheek (1992) also argues that twentieth century life is deeply influenced by science and technology.

Many citizens are ill-prepared to exercise citizenship rights when facing complex social issues involving science and technology. Educating students about these complex issues and their underlying scientific and technological principles is vital to the future of

our society. Helping them both understand and think through the implications of the social nature and culture of science and technology is essential to a well-rounded education as we enter the twenty-first century (Cheek 1992:1).

There is thus a need for greater efforts to be made by scientists and citizens in the dissemination of technical information. As noted earlier, the twentieth century public is faced with several issues that have scientific and technological aspects, for example, acid rain, the solid waste crisis, global warming, ozone layer depletion, information technologies, abortion, immunization and the like. A scientifically illiterate public will not help much in making meaningful decisions concerning these issues.

The scientific illiteracy of the public pose a serious problem for a democracy where each citizen is expected to exercise his or her right to vote and express opinions about matters of public concern. A scientifically literate citizen, for example, will make a responsible contribution to the debate of the dumping of nuclear wastes by foreign countries on South African soil; he or she can evaluate the danger posed to our environment by storing Iran's oil next to our sea *vis-a-vis* economic advantages of the endeavour; *etcetera*.

Furthermore, science literacy is important in that technological innovations will not be treated with suspicion, but will be used to enhance people's standard of living. For example, many black senior citizens prefer to wait for hours in long queues for their monthly pension payouts instead of making use of banking facilities. Besides being a costly venture for the state, a number of pensioners lost their lives in these queues due to severe weather conditions. Scientific literacy will help, particularly in the black population, in areas such as health awareness, energy consumption, environmental pollution and the like.

It can be concluded, therefore, that science literacy should be a national priority. That there is a need for active and organized efforts from scientists and educators to promote science education and public understanding of science. Consequently, there is a need for programmes that will foster an awareness and appreciation of science and scientists particularly among school pupils. This is important if we consider that for most people, science education begins and ends in school mathematics and physical science classes. Next, the researcher gives an exposition on the role that institutions of learning (schools, universities) play in promoting science education and public understanding of science.

### **(c) CLARIFICATION OF CONTROVERSIAL ISSUES**

Before discussing the role of schools and tertiary institutions in society, the following clarification is crucial. While the researcher holds the view that innovations in the fields of science and technology can make the world a better place in which to live, such innovations are not viewed in the narrow sense as *magic, saviour and hope* (Cheek 1992:34). Science and technology, on their own, cannot increase the

standard of living of members in any particular country. Referring to developing countries, Lord Blackett (in Jones 1971:4) argues that "unless the social and political structure of the country is such as to put economic growth on high priority, neither education, nor management skills, nor capital, nor science and technology, nor all together, will raise the living standards of the mass of the population."

In addition, the researcher's plea of *promoting science education and public understanding of science* should also not be regarded as assuming the *enlightenment* view of society as propounded in Irwin's (1995) dialectical theory. Irwin (1995:31) depicts a polarization between *enlightenment* and *critical* views of the relationship between science and the public. The enlightenment approach emphasizes the positive contribution of science to everyday life and defines the problem as how to carry (or push) the public towards *scientific enlightenment* (p.31). Irwin give examples (dispute over the use of 2,4,5-T herbicide, controversies about the mad cows disease, information concerning major hazards) where public outcry and resistance to issues that affect them have been silenced by a scientific answer. In this regard, any problematic relationship between science and citizens is viewed as a consequence of either public ignorance or public irrationality (p.14).

The critical approach, on the other hand, is wary of the enlightenment ideology and stresses the negative consequences of much of contemporary science for everyday life (p.31). Information technology, for example, while offering vastly improved communication systems, greater efficiency, easy access to databases and knowledge systems, the possibilities of more leisure time, *et cetera*, it also offers the routinization of clerical tasks, unemployment, the centralization of power and the potential (through advanced security systems and databases) for loss of freedom and autonomy (p.3). This is just one kind of impact considered in the *critical approach* as part of the disenchantment produced by scientific rationality. Others include: biotechnology (test-tube babies), environmental issues (fast cars, energy-consuming domestic technologies, new products), new manufacturing systems, satellite broadcasting, nuclear power, and the like.

Problems such as these are regrettable but are useful in shaping scientific accountability and in enhancing educational reforms. Consequently, new fields of study evolve which aims at providing a holistic study of science related issues. In the United States of America, for example, several schools, colleges and universities offer a subject called Science, Technology, and Science (STS). STS education emphasizes complex thinking and decision making leading to a product (tangible or intellectual) and/or responsible social action. STS courses attempt to address most of the issues that are objectionable in the enlightenment approach.

As far as school science education is concerned, some major paradigm shifts in curriculum developments have occurred during the 1980s and early 1990s. As such, the researcher subscribes to the following issues that are increasingly seen as important for science education:

- addressing real-life situations;
- relating science to wider societal and technological issues;
- developing scientific literacy in the context of active and responsible citizenship;
- promoting science as a cultural phenomenon;
- ensuring that science is more person oriented;
- starting from and building on children's existing knowledge and experience;
- using problem-solving activities to develop creativity and promote decision-making and social skills; and
- enhancing each student's self-image and self-worth (Hodson 1993:685).

These changes in emphasis have particular relevance to the objections posed by Irwin. Hopefully, such changes in emphasis will result in better decision making by future scientists who are products of the new curricula.

### **2.2.1.2 THE ROLE OF INSTITUTIONS OF LEARNING**

#### **(a) ORIENTATION**

In this section, the role that schools play in educating members of the society will be described. Although the aim is to indicate the relationship between school science education and the society, the former cannot be analysed in isolation from the total national school system. In other words, the same problems that beset the national school system find their way into science education.

#### **(b) PRACTICES IN THE OLD SOUTH AFRICA**

Schools are societal institutions that are called on to perform several functions. According to Herman (1995:261):

Schools and universities world-wide are required to fulfil a variety of functions, one of which is to serve as selection and certification agencies, making sure that individuals are suited to, and competent for, their social and occupational roles. They also contribute to personal development, to giving everybody a fair chance and are supposed to contribute to greater social equality.

Schools and universities play a crucial role in the personal development of members of a society. Societies, particularly as the state, have regarded the education system as an important vehicle for advancing, among others, the standard of living of its members. Consequently, the nature of schools in multiracial countries usually varies according to which societal group is in power. This is true of South Africa where "education has been part of the arena of debate for fundamental societal change from the apartheid order to a just, non-racial democratic state" (Herman 1995:261). Schooling and selection for

higher education, which was skewed towards whites, are being challenged to meet goals of equity and development of the hugely disadvantaged black majority of the population. There is a demand that education in the new South Africa should meet the six criteria of equity, non-sexism, non-racism, a unitary system in education and training, democracy and general redress (Donn 1995:203).

According to Levine (in Herman 1995:261), education in a given society is intimately related to the society's status mobility system, methods of self-advancement in a hierarchy of social goods, particularly in the occupational ladder of modern industrial societies. Schooling is seen as culturally organised formulae for preparing children to participate in the status mobility system of their society, including teaching and learning of rules of behaviour for achievement, instrumental competencies and actual behaviours required to advance in the status mobility system. Schools certify young adults for eligibility to compete for different levels of jobs and salaries. That is, school credentials serves as a culturally institutionalised device for job placement and remuneration.

In the South African context, Bantu Education was instituted in 1953 for advancing the social status of whites relative to blacks. This education policy was aimed at denying blacks access to adequate schooling opportunities while providing whites with quality education. Because formal education is a major producer of upward social and economic mobility (Herman 1995:262), the South African society was eventually stratified into different socioeconomic levels according to race. On average, whites were in the high socioeconomic levels accompanied by a high status and blacks were in the low socioeconomic, low-class level. In pursuit of social upliftment, black politicians tried to change the education system. Moves were made to strive for equity in education and children were encouraged, particularly in the 1980s, to attend school. This resulted in increased enrolments in black schools. In 1989, for example, a crisis emerged due to overcrowding in black secondary schools. In particular, the number of black matriculants increased more than their white counterparts although blacks were experiencing high failure rates (Table 2.1).

**Table 2.1 Senior Certificate matriculation results, 1989**

	ENTRIES	MATRIC PASSES	SC PASSES	TOTAL PASSES	FAILURES
BLACK	209,319	21,357 10.0%	66,153 31.6%	87,510 41.8%	121,809 58.2%
COLOURED	22,666	4044 17.8%	12,431 54.8%	16,475 72.7%	6191 27.3%
INDIAN	14,191	5889 41.5%	7393 52.1%	13,282 93.6%	909 6.4%
WHITE	70,666	29,933 42.4%	37,892 53.6%	67,825 96.0%	2841 4.0%

Source: Herman (1995:266).

However, substantial inequalities in social and economic circumstances persisted. According to Levin (in Herman 1995:263), South Africa is experiencing similar dilemmas of comprehensive secondary school reforms as in Western Europe. The common thread is capitalism. According to Levin, the schooling systems of capitalist countries serve dual functions. On the one hand, they must contribute to reproducing wage labour for the systems of monopoly capitalism that dominate the economies, on the other, they must represent the primary agent for providing equality and mobility to the vast majority of the populations of countries. But, there is a basic incompatibility between these two roles. The reproduction needs of capitalist production require highly unequal educational outcomes while the ideology of the educational system inspire expectations and policies of greater equality, and schooling expansion to satisfy the aspirations for social mobility. As long as the structural inequalities of capitalist production and their associated inequalities in adult status persist, the total system of schooling must contrive to reproduce those inequalities. This means that greater equality in educational treatment at the secondary and post-secondary levels must necessarily be compensated by increasing inequalities in the translation of education into occupational positions in the labour market, if the capitalist workforce is to be reproduced. The unequal preparation and allocation of workers for the work hierarchy will require compensating inequalities at some higher level if egalitarian educational reforms are introduced at a lower level.

As such, formal education does not necessarily promote opportunity for the poor (blacks). Farrel (in Herman 1995:262) claims that even if the children of the poor achieve a relatively high level of education, which is itself unlikely, this will not ordinarily produce in the labour market, or in their adult lives generally, the same benefits as those received by the children of the rich. Farrel forwards three reasons to support his argument:

- (i) The labour market and political system can be manipulated by the well-to-do to maintain advantages for their offspring.
- (ii) As educational systems have expanded more rapidly than the modern sectors of the economy there is increasing *educated unemployment*, which has a greater negative effect upon the children of the poor than upon those of the rich.
- (iii) As the educational system expands rapidly, educational qualifications become devalued. Jobs that a few years ago required only a primary school certificate may now require a secondary school diploma or more.

(c) **PRACTICES IN THE NEW SOUTH AFRICA**

The above analysis clearly portrays a bleak future for the poor and the disadvantaged. How is this situation solved by South Africans? Clearly, there is no one simple answer to this question. To this end, the following realities deserve to be mentioned.

- (i) Affirmative action programmes are implemented in South African institutes and organisations as a measure of ensuring that the well-to-do do not maintain undue advantages for their offspring. This is necessary if one considers that *job reservations* made it impossible for blacks in the apartheid era to work in certain occupations (judiciary, management, *et cetera*). Although the success rate and adequacy of affirmative action (as far as maintaining achieved standards and enhancing competency) is yet to be determined, it nevertheless provides hope for blacks who have achieved some form of education.
- (ii) School qualifications are losing value due to an expansion of the education system. In their final report, the NCHE (1996:52) reports that education levels greatly affect employability in South Africa. For example, in 1971, close to 43% of South Africa's formally employed were in the lowest skill level corresponding to less than seven years of schooling and only 11,8% were in the highest level corresponding to degrees and diplomas. By 1994, just under 25% of the formally employed were in the lowest skill level, and around 20% were in the highest level. As such, employability is increased by having a post-Standard 10 certificate or a university degree: the largest numbers of unemployed are African women with less than 10 years of education, followed by matriculants with no further training or no previous employment. More years of schooling not only improve the earning power of the worker but also translate into a higher probability of finding a job. Those graduates with degrees and diplomas preparing them to work in finance, mining, medicine, law or sophisticated educational services as professionals, technicians or managers are already finding well-paid jobs. It is noteworthy that educational attainment up to matric makes little difference in terms of obtaining employment, but having a post-secondary school qualification is an entirely different matter.
- (iii) Although the problem of *educated unemployment* is not yet experienced in South Africa, it nevertheless seems inevitable in the light of the NCHE's (1996:77) proposal for massification of the higher education system. "Mass access to higher education is likely to create unforeseen problems which may not be in the interest of either the students, the university or society-at-large" (Herman 1995:263). In the advent of massification of higher education, the structure of admission to higher education should be reviewed. Two options are available. Option one: increase total enrolments leaving the same structure of enrolments by field of study. According to Zymelman (1990:25), this option is doomed to failure for two reasons: budgetary constraints

and poor employment prospects for the vast majority of graduates from fields other than science and engineering. Option two: change the enrolment structure to favour science and engineering. This is a more realistic option because the share of science and engineering can be increased without impinging too much on the other fields in an expanding higher education system (Zymelman 1990:26). Here again, the effects of greater participation in higher education are yet to be seen.

- (iv) In an expanding education system, however, graduates who will be first to experience unemployment will be those in non-science and non-professional fields. Besides the personal advantage of finding employment, science graduates will be of benefit to the society in that they will improve the country's economic development.

### **2.2.1.3 SUMMARY**

The literature study has shown that science plays an important role in society. This is evidenced by the essential contribution that scientific literate people make in daily social issues. Through wise decisions made by scientifically literate people, societal practices and institutions will develop for the better. Scientific literacy is not only of benefit to the society, it also endows individuals to make informed decisions on matters of health, safety, the environment, and the like. In short, scientific literacy encourages citizens to participate fully in any democracy.

The literature study has also shown that schools are well placed to invoke the interest of pupils towards science. They are, however, limited in this regard due to negative intervention from outside, particularly the manipulative intervention of the state. Such intervention might be detrimental to school education so that schooling is not seen as a likely route to employment or success. Philanthropic intervention by the state, however, is likely to cultivate interest in science education and this will be of benefit to the entire society.

### **2.2.2 SCIENCE AND THE ECONOMY**

The South African economy has been based on the export of gold for many years. According to Donn (1995:208), the *gold factor* saw the emergence of an apparently stable economy during the 1960s and 1970s when the price of gold boomed. To make gold profitable, however, wages had to be kept down and a highly skilled workforce was not necessary. By the late 1970s a period of economic crisis had begun. The crisis was caused by excessive concentration of economic activities on mineral exports; dependence on foreign technology; the preponderance of an inefficient, capital-intensive, import-substituting manufacturing sector; and the poor performance of manufacturers in world markets (NEPI



1992a:9). This period was also characterised by political confrontation, social unrest, sanctions and international isolation.

After independence in 1994, the government of national unity was faced with a challenge of making the economy to grow. The whole process of reconstruction and development hinged on the ability of the economy to grow. According to Bawa (1994:1), the South African economy should develop appropriate labour-based industrial activities that will overcome unemployment, while on the other hand, interface with the global economy that is dominated by information technologies to be competitive internationally. To compete in the world market, South Africa must develop a technologically-skilled workforce (Donn 1995:208; NEPI 1992a:25) and produce an increasing number of skilled professionals and knowledge workers with world-class skills to strengthen its enterprises (NCHE 1996:91).

The low number of South African graduates in science and technology, however, does not meet the needs of industrial restructuring and certain high-tech national development strategies (Bawa 1994:1). Will this inability to produce native born scientists and engineers affect our nation's economic growth? In an analysis of America's situation, Cheek (1992:9-10) argues that the lack of scientists and engineers can be circumvented by importing scientists from abroad, and as such is no cause for alarm. He argues that although American school children's achievement in science is low compared to other countries (Menis & Fraser 1992:131), American companies (using products of its educational system) have produced technologies that are of world-class status. Such successes, avers Cheek, should give us pause before quickly ascribing a lack of economic competitiveness to school education. Furthermore, Jones (1971:12) points out that for developed countries, it is not necessary, nor normally practicable, to rely entirely on the country's own scientific output. The results of scientific research are available internationally through publications. Most technological innovations are also available in the marketplace in the shape of new machines or materials, or through the purchase of patents and licences.

What, then, is the case for producing indigenous scientists and engineers, bearing in mind that unit costs in their training are usually higher than in the rest of secondary and tertiary education? Zymelman (1990:1-2), using economic theory, points out that technical change is a major factor in economic growth. Technical change, in real life, is a result of a confluence of many factors: scientific and technical knowledge, better organization and management, more skilful and effective labour, as well as proper economic and social environments. In this way scientific knowledge is viewed as a necessary ingredient for, and not a cause of, economic growth. Furthermore, Zymelman (1990:2-3) argues for the case for developing an indigenous science establishment on the following grounds:

- There is a minimum threshold of scientific knowledge required for the proficient performance of technicians and professionals (doctors, engineers, agriculturists, *et cetera*) in the economy. This threshold is rising continuously with the expansion of scientific knowledge and improvement

of technology. To impart this knowledge it is necessary to have a functioning teaching scientific community that is able to progress in science.

- While technological knowledge can be acquired from abroad, to facilitate the transfer it is important to have individuals that can understand, assimilate, and, if necessary, transform and adapt this knowledge to local conditions. This, again, requires a minimum quantum of people with a solid scientific background.
- A modern technological society requires more than the ability to perform skilfully; it requires a positive attitude to modernization. Science, by its questioning nature, influences the way man looks at the universe. This positive general attitude towards science can be fostered in the population at large only by a local scientific effort.
- To keep the morale of those engaged in science teaching, be it for developing technology, skills or attitudes, it is crucial to develop and maintain scientific activities and link the local scientists to the international scientific community.

It is evident from Zymelman's argument that the development of an indigenous science establishment is imperative. This has implications for school science education. It implies that more students should be prepared for tertiary science studies and their level of achievement in the sciences should be increased. As such science courses must be made attractive to students and must be integrated into all levels of the national school curriculum to give substance to a *science and mathematics for all* policy (ANC 1995:89). An increased scientific sector will thus be realised and this will have consequences for economic development.

### 2.2.3 SCIENCE AND TECHNOLOGY

Economic development in Sub-Saharan African countries depends foremost on the ability of their societies to establish technological progress as an ongoing process. This ability requires the capacity to choose, acquire, adapt, generate, and apply technologies. Scientific knowledge is a basic ingredient that helps develop this capacity (Wyss in Zymelman 1990:v).

It is noteworthy that Wyss regards scientific knowledge as an ingredient, and not a prerequisite for, technological development. There has been much debate about the relationship between science and technology. This is precipitated by the fact that science and technology are usually mentioned together. We need, however, to distinguish between them for conceptual clarity.

Several working definitions have been provided by people who are active in this field. There is, however, no complete consensus about the nature of science and technology due to competing values,

differential knowledge and varied life experiences (Cheek 1992:32). In a review of definitions of science and technology, Cheek (1992:32-35) mentions the following definitions as important.

Aikenhead's definitions:

*technology*: (1) applies scientific and other domains of knowledge/resources, (2) to practical problems that arise from human purposes, (3) guided and constrained by organizational systems, people, hardware and nature.

*science*: is a social institution possessing disciplined processes that utilize knowledge and technique to achieve conceptual, material and social goals.

Aikenhead defines science as a social institution and focuses his definition on the epistemology of science. His definition is based on the theory of Science, Technology and Society.

Bybee's definitions:

*technology*: the application of scientific knowledge to solve practical problems to achieve human goals. A body of knowledge, developed by a culture, that provides methods or means to control the environment, extract resources, produce goods and services and improve the quality of life.

*science*: a systematic, objective search for understandings of the natural and human world. A body of knowledge, formed through continuous inquiry. Science is characterized by use of an empirical approach, statements of generality (laws, principles, theories) and testing to confirm, refute, or modify knowledge about natural phenomena.

Bybee's definition of technology as the *application of scientific knowledge* raises some problems. Historically, technology developed in many instances without the back-up of science, but in the end scientific advances found their way into technology (Zymelman 1990:1). For example, the British Navy successfully treated scurvy by lemon or lime juice over 130 years before ascorbic acid was identified and understood to be the key ingredient preventing this dreaded disease.

The boundaries between modern science and technology, however, are far from being clear. According to Zymelman (1990:1), science and technology exist in a symbiotic relationship: technology utilizes the advances of science to produce new and better products, while science progresses because of the validation or rejection of theories through experimentation done with instruments created with the available technology. He hastens to indicate that it does not mean that either science or technology cannot progress without advances in the other. There are many instances where modern technologies

were developed without the necessary scientific understanding. The development of the atomic bomb by the Manhattan Project, avers Zymelman, is one good example where pioneer technologies and techniques far outstripped attendant scientific understandings. The relationship between science and technology, however, is lately becoming closer and, increasingly, advances in technology depend more on basic scientific knowledge (Zymelman 1990:1).

Technologically, South Africa is experiencing a revolution and careers become increasingly dependent upon sophisticated technological skills (Wilkinson, Reuter & Kriel 1987:47). Under the apartheid regime, however, the majority of South Africans were denied access to science and technology, both in the educational sphere and in terms of the knowledge of the wider social applications of technology (Donn 1995:203). It is not surprising then that South Africa has an unfavourable position with regard to technical personnel compared to the rest of the world. According to Wilkinson *et al.* (1987:47), only 1,7% of the technical personnel (per thousand of the population) are scientists or engineers. The corresponding figure for technicians is 0,4%. These figures are far below the world averages of 7,1% and 12,2% respectively.

South Africa is also lagging behind in international terms with respect to the training of engineers at universities. Cooper (1995:247) estimates that South Africa produces 35 graduating engineers per million of population, compared to Japan's 500 and Australia's 220 per million. And South Korea, with a population nearly equal to South Africa's, produced around 27 000 engineering graduates annually to South Africa's 1500 in the late 1980s. Technikons, which were established as *institutes of technology*, are also producing few graduates in science and technology. In an investigation of Technikons in South Africa, Cooper (1995) found a disturbing situation. The total number of students enrolled in science and technology in the 15 technikons was a staggering 32% (15% engineering + 17% other sciences) for 1991. Few black students were enrolled in these fields (23%) as compared to commerce/management fields (30%). Donn (1995:223) reports that in 1994, 85% of the graduates from the post-secondary education sector in the sciences and engineering were white. This is consonant with the 85% of the science and technology personnel in South Africa which is white.

Cooper (1995:248) also indicates that there is a shift away from science and technology enrolments at both universities and technikons. Such findings have prompted the new government of national unity to investigate and launch technology as a school subject. The impact this will have on the national curriculum and science education in particular, has yet not been determined.

To sum up, it was shown that scientific knowledge and technological developments evolved into a closely knit, interwoven relationship. With increasing dependence of technological developments on scientific knowledge, science education becomes a necessity for national development. The low participation rate of South Africans, particularly blacks, in science courses thus poses a serious threat

to national development. More focus must be placed, therefore, on science education in the National Education System.

## **2.3 SCIENCE IN THE EDUCATION SYSTEM**

### **2.3.1 ORIENTATION**

According to the new act, which is yet to be realised, it is compulsory for children to attend school for a minimum of nine years or up to the age of fifteen (School Bills Act of 1996). This translates to a compulsory education of seven years of primary education and two years of secondary education. As stated earlier, this has yet to be realised since, for example, there are yet no examinations (that could lead to a certificate) at the end of the compulsory school phase. Furthermore, the compulsory school period is not free and parents have to pay for compulsory school fees levied by governing bodies. Also, post-compulsory schooling (standard eight to ten) occurs in the same premises used for compulsory secondary education. As nothing further can be said about the new schooling dispensation, the researcher will focus on the pre-1996 dispensation.

### **2.3.2 EDUCATION UNDER THE OLD ACT**

#### **2.3.2.1 STRUCTURE OF THE SCHOOL SYSTEM**

The South African education system was based on a seven-year primary education, five years secondary education (two years of junior secondary school, three years of senior secondary school), and three years of university education. School education therefore spanned over twelve years.

The school system was very examination-orientated, with an annual promotional examination at the end of the school year. In addition, one or two more examinations were written in all examination subjects during the academic year. Promotion was not automatic but depended upon success in final examinations. As a result examinations had a powerful influence on parents, teachers and pupils and formed part of the hidden curriculum (Herman 1995:265). It also influenced other aspects such as retention rates. Figures 2.1 and 2.2 show the inadequate retention rates in black schools as compared to white schools. These figures clearly show that only a few black students were able to complete standard ten. A pass at standard ten is a necessary requirement for further studies at technikons and universities.

**Figure 2.1 Retention rates in white schools.**

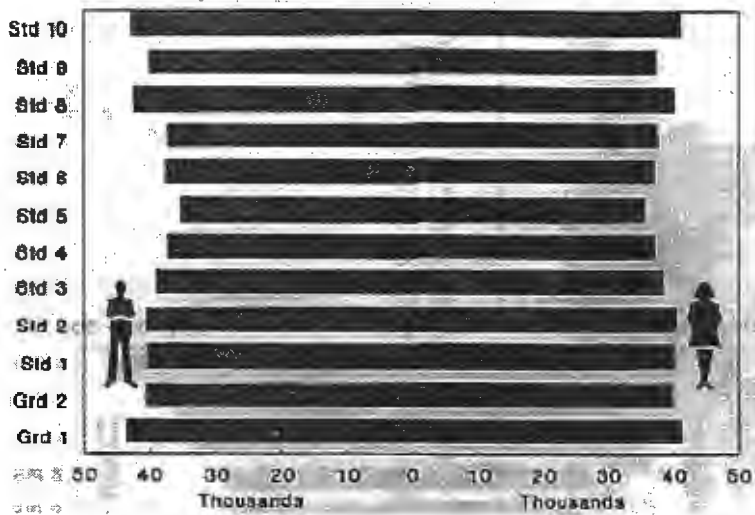

Enrolled white pupils in primary and secondary education (technical colleges included) in the RSA according to level of education and sex for 1992. (Source: DNE 1993)

**Figure 2.2 Retention rates in black schools.**

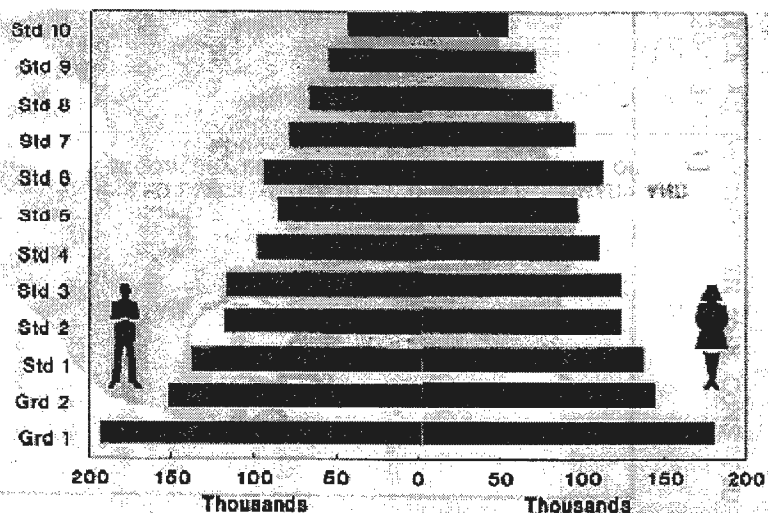

Enrolled black pupils (excluding self-governing territories and TBVC states) in primary and secondary education (technical colleges included) according to level of education and sex for 1992. (Source: DNE 1993)

After a minimum of twelve years of schooling, the school-leaving examination (Senior Certificate) was written. According to Herman (1995:265), the examination in the pre-1994 era was conducted by nine examining authorities each for its own constituency and controlled by a statutory body, the Joint Matriculation Board (JMB). The various departments of education (19) and most universities had representation on the JMB. Each examining authority conducted its own examination and the final marks were adjusted if necessary to bring them in line with national norms approved by the JMB.

The senior Certificate examination was a six or seven subject examination at Higher or Standard Grade. Each candidate was required to pass at least five subjects, one of which had to be a First Language on the Higher Grade. Candidates were given an aggregate score, the average of the scores of the individual subjects. To be eligible for undergraduate studies at any university, a candidate had to obtain Matriculation Exemption, subject to additional entrance requirements which individual universities may set. For Matriculation Exemption to be obtained, at least two other subjects apart from the First Language, had to be passed on the Higher Grade. In addition, the candidate had to fulfil other requirements of subject choices and pass marks.

### 2.3.2.2 THE SCIENCE CURRICULUM

Concerning the science curriculum, Table 2.2 shows the subjects offered and the subject choices in primary and secondary schools.

**Table 2.2 School science and mathematics subjects and availability of choice**

GRADE	SUBJECT	CHOICE
1-4	Environmental study, mathematics	No
5-9 (standard 3-7)	General science, mathematics	No
10-12 (standard 8-10)	Physical science, biology, mathematics	Yes

Source: Adapted from Kahn (1994:26).

Table 2.3 shows a typical *sciences stream* curriculum at senior secondary level in black schools.



**Table 2.3 Typical subject combination for a senior secondary level science stream in black schools**

Subject	Choice	LEVEL(Higher or Lower Grade)	No. of periods/week
English (2nd) Language	NO	HG	8
Afrikaans (2nd) Language	YES	HG	8
African (1st)language	NO	HG	8
Mathematics	NO	HG or SG	8
Physical Science	NO	HG or SG	8
Biology	YES	HG or SG	8
Non-Examinable Subject 1	NO	N/A	1
Non-Examinable Subject 2	NO	N/A	1

Non-Examinable Subjects include Guidance, Physical Training, Religious education, and the like.

A closer look at table 2.3 indicates that the time allocated to teach physical science is the same as in all other subjects; that is, the same time is allocated for teaching a practical subject and a special language course for communication (the third language). This is an unfavourable situation since more time is needed to teach physical science. For each standard (six to ten) there is an official *work-programme* that must be followed by every subject teacher. The work-programme stipulates which sections of the syllabus must be taught at a certain time in the school calendar. Part of the evaluation of teachers involves ascertaining whether they keep up with the work-programme or not. Consequently, teachers do not have time to teach inquiry and investigative skills.

Some schools have a flexible curriculum which allows students to choose other subjects (usually Geography or Commercial subjects) in the place of Biology and/or Afrikaans. A typical school day begins at eight 'o'clock (08H00) in the morning and ends at half past two (14H30) in the afternoon. It is divided into ten to eleven periods with each period lasting from thirty to thirty-five minutes. Classes are held five days a week from Monday to Friday. Students stay in the same room throughout the day. The exception is during choice subjects and African language periods where they mix with children from other classes. Each teacher will come to the students' room at the time scheduled for that teacher's subject. Newer high schools may have a special laboratory room. On a day when there is a laboratory

activity scheduled in a science course, the class may go to the laboratory room for that day only. In most instances, these laboratory rooms are converted into regular classes due to lack of space that is caused by overcrowding. Table 2.4 presents a typical timetable of a single week of courses for students in a senior secondary school class.

**Table 2.4 A typical timetable for a senior secondary school class**

P	Monday	Tuesday	Wednesday	Thursday	Friday
1	Maths	P.Science	English	P.Science	Maths
2	Maths	P.Science	English	P.Science	P.Science
3	P.Science	English	Maths	English	P.Science
4	English	English	Afr.Lang	Afrikaans	Afr.Lang
5	English	Biology	Guidance	Maths	Afr.Lang
6	Afr.Lang	Afr.Lang	P.Science	Maths	Afrikaans
7	Afr.Lang	Afr.Lang	Biology	Biology	Afrikaans
8	Biology	Maths	Biology	Biology	Biology
9	Afrikaans	Maths	Afrikaans	R.E.	Biology
10	Afrikaans	Afrikaans	Afrikaans	Afr.Lang	English

P = periods are 30 - 35 minutes in length.  
RE = Religious Education.

### 2.3.2.3 DEFICIENCIES IN THE SCIENCE CURRICULUM

Several problems were inherent in this science curriculum. Firstly, the emphasis of an inflexible work programme which teachers had to follow created problems for the teaching of physical science at lower standards. The components of general science are biology and physical science and the DET work programme for general science suggested that teachers must teach the biology component of general science before the physical science component. Due to general problems facing many schools (teaching starting late in the first quarter, disruptions, teachers' absenteeism, and the like) the physical science component was left either out or merely summarised for examination purposes. Also, since the common occurrence in black schools was to allocate general science to one teacher (who, in most cases, was actually a "biology teacher"), physical science in junior secondary schools was not properly attended to. The effect of this neglect, amongst others, became evident in senior secondary level where, in 1991 for example, few students chose physical science (16.4%) as compared to the massive 83.5%

enrolment in biology (Van der Linde, Van der Wal & Wilkinson 1994:49). In this regard the curriculum did not promote science.

Secondly, gender differences in science enrolments were also evident. According to Kahn (1994:25), the standard eight subject enrolments revealed that African males and females were more or less equally represented in physical science. The skewed proportions held true even when allowance was made for the 20 percent greater school enrolment of African females compared with males. This translated to a lower total enrolment of females as compared to males. Besides South Africa, other countries also experienced the same problem of low female enrolments in school science courses (Greenfield 1996:901; Cheek 1992:10).

Thirdly, the language of instruction for the majority of black students was problematic. In black schools, the home language is the medium of instruction up to standard two. From standard three, most schools opt for English as the medium of instruction. However, important scientific concepts are taught in the early standards (four to six) during which the students do not have complete command of the English language. Consequently, they cannot cope with the scientific language and thus regard science as a difficult subject.

Fourth, the aims and syllabuses of physical science did not have many aspects that are necessary for scientific literacy in school leavers. This is evident when the aims in the official syllabus document are analysed. The aims are listed below.

- (i) To provide pupils with the necessary subject knowledge and comprehension, that is, knowledge of the subject as science and as technology.
- (ii) To develop in pupils the necessary skills, techniques and methods of science, such as handling of certain apparatus, the techniques of measuring, *et cetera*.
- (iii) To develop in pupils the desirable scientific attitudes, such as interest in natural phenomena, desire for knowledge, critical thinking, *et cetera*.
- (iv) To introduce pupils to the scientific explanation of phenomena.
- (v) To introduce pupils to the use of scientific language and terminology.
- (vi) To introduce pupils to the applications of science in industry and in everyday life.

- (vii) To help pupils obtain perspective in life. For example, to develop a reverence for the Creator and an esteem for the wonders of the created universe through contact with the subject matter.

Aim (vi), for example, does not emphasise South African industries and hence teachers did not include this important aspect of scientific literacy. Other shortcomings of the syllabuses are given by Gray (1989:7):

- There was no mention of economically important industries such as ISCOR, SASOL and ALUSAF.
- There was no reference to the particle accelerator in the Cape.
- There was no reference to the mining industry.
- There was little mention of alternating current electricity or the electrolytic process.
- The absence of all but brief mentions of *science in South Africa* cannot be regarded as improving the local image of the scientific professions.

Finally, the content approach (that is, stipulating the content and amount of content that must be covered in a given time period) lend itself to rote teaching and learning. As such investigative approaches were not used (Kahn 1994:26). Moreover, applied science, technology and the social and ethical aspects of science were excluded from the classroom. Worse still, a pass in school science did not necessarily translate into successful science studies at technikons or universities (Sander 1988:361; De Vetta 1993:19). This scenario indicates that there is a crisis in the provision of science education for a large population of school going children in South Africa.

## 2.4 THE CRISIS IN SCIENCE EDUCATION

An analysis of the crisis in science education cannot be made in isolation but should be seen as emanating from the broad crisis in South African education. Several aspects (poor teacher training, high failure rates, low participation rates in science, *et cetera*) of the crisis have already been mentioned above. The white paper on education (RSA 1996:29) sums the previous and present realities in South African education as follows:

The former racially and ethnically organised departments of education embodied substantial inequalities in per capita spending, the largest disparities being accounted for by "the skewed distribution of teacher qualifications, inappropriate linking of salary levels to qualifications, and disparities in learner/teacher ratios." Taken together with the inequitable distribution of education facilities and learning resources, these disparities have resulted in both unequal

access to education and unequal learning outcomes. Spending disparities reflect the racial hierarchy of the old dispensation.

We can therefore expect that science education in black schools will be in the same extent of crisis, perhaps even more, as depicted above. Several factors have been singled out as contributing to the apparent crisis, namely, shortage of well-trained and motivated teachers, curriculum changes which have not been implemented as planned, rapid increase in enrolments at secondary level, a lack of resources, poor teaching habits, lack of coordination between stakeholders and insufficient planning (Van der Linde, Van der Wal & Wilkinson 1994:49). The contribution of these factors towards the crisis is described in the following sections.

## **2.4.1 TEACHER AND TEACHING RELATED PROBLEMS**

### **2.4.1.1 PRESERVICE EDUCATION OF TEACHERS**

According to the constitution of 1983 (Act 110 of 1983) and the National Policy for General Education Affairs (Act 76 of 1984), teacher education prior to 1994 was an *own affair* (NEPI 1992c:4). In accordance with the *own affairs* policy, the bulk of black teachers was trained in colleges administered by the former DET. In 1990, for example, 48 975 students were enrolled in seventy-two colleges of education (Masitsa 1995:73-74). The DET determined the enrolment of students, the appointment of the teaching staff and the curriculum followed in these colleges. Teachers and college lecturers were classified as civil service educators and had a civil servant relationship with the state. The implication is that these colleges of education were severely constrained in their capacity for autonomous professional activity (NEPI 1992c:25).

Low admission requirements characterized teacher training in DET colleges since its inception. Until the early 1980s, possession of a standard eight certificate was the minimum requirement for entry into a teacher training college. Teachers were consequently underqualified and often had to teach beyond the limits of their training. A common occurrence was for the school staff members who studied a particular subject, say physical science, to the highest level as a school subject to be designated as "science teacher" (Khan 1994:27). Such teachers obviously did not possess the professional and academic training in subjects that they taught at school. Admission criteria were subsequently changed in the late 1980s and a senior certificate became a prerequisite. The duration of the training also changed from two to three years (matric + three years). In contrast, the norm within white education was matriculation plus four years. However, access to these colleges became difficult for many aspirants who lacked a matriculation certificate. The statistics for 1991 (Table 2.5) show that 57.1% of black teachers in the DET system fell below the M + three qualification. At primary school level this rises to 74.9% (NEPI 1992c:23).

**Table 2.5 Qualifications of black school teachers in 1991 (Adapted from NEPI 1992c:24).**

DET				Self governing national states		
Primary	Secondary	Total	Teachers	Primary	Secondary	Total
			Unqualified with:			
2 769	18	2 787	Std 8 or lower	2 061	6	2 067
9	13	22	Technical	4	13	17
2 821	342	3 163	Matric or Snr Cert.	8 852	2 545	11 397
19	232	251	Degree	24	359	383
5 618	605	6 223	Sub-total	10 941	2 923	13 864
			Qualified with:			
648	11	1 659	Std 6	888	1	889
9 045	377	9 422	Std 8	7 678	116	7 794
5	3	8	Technical	9	5	14
16 208	4 008	20 216	Std 10 + less than 3-year training	19 092	3 721	22 813
7 600	7 525	15 125	Std 10 + 3-year training	3 295	5 400	8 695
1 166	1 697	2 863	Std 10 + 4-year training	10 746	10 351	21 07
414	3 052	3 466	Degree	483	4 652	5 135
36 086	16 673	52 759	Sub-total	42 191	24 246	66 437
41 704	17 278	58 982	TOTAL	53 132	27 169	80 301

Even then, admission to teacher colleges was not based on a high level of scholastic achievement. Students who would not receive admission to universities qualified for admission at the colleges. "Therefore, whether they planned to become teachers or not, most pupils with school-leaving certificates who wished to acquire a post secondary education had virtually only one option to follow, namely to enrol at a college of education - a situation encouraged by low admission requirements" (Masitsa 1995:75). This, together with the inadequate distribution of these colleges, resulted in a situation where a regional disparity in teacher supply occurred. According to the NEPI (1992c:11) investigation, regions like QwaQwa, Lebowa, Ciskei, Venda, Bophutatswana, and large parts of the DET system were faced with an oversupply of teachers whereas others like Transkei, Gazankulu, Kangwane, KwaNdebele, and

especially KwaZulu, had considerable shortages. The quality of teachers produced by these colleges was generally poor and had the potential of drawing in candidates who, as shown above, are unmotivated and uninterested to follow the profession. In one investigation, it was found that in-service teachers of mathematics achieved an average of 36,79% in the subject that they taught at school (Masitsa 1995:77). Clearly, the products of the colleges of education under the auspices of the DET were not up to standard.

According to Kahn (1994:28), the problem was further exacerbated by the ethos of these colleges which were essentially schools rather than tertiary institutions. Staff members of these colleges did not generally meet the criteria laid down for appointment, and had inappropriate teaching experience (NEPI 1992c:29). The courses offered at these colleges stressed content and consequently the emphasis fell on rote memorization of facts. The NEPI (1992c) report gives a detailed exposition of the widespread dissatisfaction concerning several aspects of the DET colleges of education.

Besides DET colleges, preservice teacher training was also offered at universities and technikons. Few students, however, chose this option probably because it would be much easier to obtain teaching qualifications through the colleges of education. Due to the difficulty of finding exact figures from the authorities, the numbers of teachers who received their initial training at universities or technikons are, to my knowledge, not known. A picture thereof, however, can be gleaned from a study carried out by Wilkinson *et al.* (1987). From a total of two hundred and thirty-seven (237) physical science teachers investigated, only 9,6% possessed a university degree. This unsatisfactory situation needs to be reviewed and decisive action must be taken.

The proposals of the NCHE (1996:156-157) will certainly help in alleviating this problem. The proposal is that colleges of education should be incorporated and administered by universities and technikons and that college teacher training programmes converted to university or technikon training programmes. Initially, this arrangement may yield few science teachers than required but it will gradually improve since the school system is undergoing major changes. The maintenance of the status quo will certainly not be of any benefit, in the short or long term. It will only succeed in producing more of the same kind, that is, more inadequately trained science teachers.

#### **2.4.1.2 PHYSICAL SCIENCE TEACHING**

There have been a low percentage of students offering science as a subject during preservice training (NEPI 1992c:20-21). Although the reasons for this are complex, the small number of students taking science at school level and the low pass rate in physical science are primary contributory factors. In 1992, for example, only 1908 matric pupils in the DET attained a higher grade in Physical Science while only 23 attained a C grade or better at standard grade level. Given such low numbers, very few Primary

Teachers Diploma (PTD) and Secondary Teachers Diploma (STD) students at college were able to take science and mathematics as their major subjects. Furthermore, only six of the colleges controlled by the DET offered physical science as a subject (Kahn 1994:27). We can therefore conclude that black students did not have easy access to science and mathematics. Without intervention, this *self-consistent loop of mediocrity* (Kahn 1994:27) will continue to operate.

Wilkinson *et al.* (1987) investigated the problems experienced by teachers of physical science in the erstwhile dependant and independent states: Kwazulu, Lebowa, Qwaqwa, Gazankulu, Kangwane and Ciskei. Their results show that in 1986, 65,2% of the teaching corps in these areas had three years of physical science teaching experience, 69% had a standard 10 certificate, only 23,6% had professional teaching certificates that permit them to teach on the senior secondary level (SSTC, HED and SED) and 34,1% had no professional teacher certificate. These statistics show that most of the teachers are ill-equipped for their teaching task.

From an analysis of the factors that teachers claim to be problems, Wilkinson *et al.* (1987) found that the problems stem from inadequate teacher training. Even though a large number of schools lack laboratories and equipment (53,5% of the respondents have laboratories although amenities and equipment are lacking), teacher training colleges did not adjust their courses to overcome these deficiencies. In practice, teachers were forced to improvise although they had no sufficient training in this regard. Teacher training colleges were also found lacking as far as equipping trainee teachers in several didactic aspects: solving problems the teacher may encounter in the classroom, laboratory organization, laboratory practices and evaluation of available textbooks, amongst others. MacDonald and Rogan (1990:122) report that teachers involved in the Science Education Project (SEP) initially relied heavily on the expository method. There was little or no use of hypothesis or speculation questions, statements or activities chiefly because they were trained by expositors themselves. Other confounding issues included the lack of well-written textbooks, the lack of technological equipment (video and television monitors, computers, *etcetera*), lack of support systems (libraries, subject advisors, remedial centres), *etcetera*. Taken together, these factors rendered physical science teaching at black schools a difficult task. The best that was offered was teacher dominated lectures and rote learning.

#### **2.4.2 IMPLEMENTATION OF CURRICULA**

As stated previously, few black teachers had the necessary competence to teach physical science in schools. Support systems were therefore imperative in the implementation of curricula. To this end the DET made use of subject advisory services. Subject advisors were charged to render specialized subject advisory services to teachers in the employ of the department. According to Masitsa (1995:80-81), subject advisors were concerned with the standard and quality of education at every level, the upgrading of the content and methodology, as well as the planning of the curriculum. Their support



included supplementing the teachers' knowledge, assisting teachers with the interpretation of the syllabuses, updating their teaching methods, establishing standards of teaching and examinations, evaluating teachers' and pupils' performance, identifying problems and assisting in solving them, and providing teachers with regular motivation in pursuit of good quality education. In short, they were to provide guidance and assistance for the subject teacher to enable them to convey to their pupils the best possible subject matter by means of the most effective and up to date subject methods.

The subject advisors were further charged with the task of upgrading the matriculation examination results. This necessitated assisting teachers on how to improve the pupils' performance. They had to give teachers guidelines on how to make pupils achieve and maintain continuous academic progress. They were to hold regular subject courses or meetings at the teachers' centres, schools, area offices, *etcetera*.

The subject advisory services encountered several stumbling blocks which rendered them ineffective and virtually nonexistent, particularly in urban areas. Firstly, subject advisors were stationed at regional and area offices of the DET. Due to their association with the authority structures of the DET, they were often barred from entering certain schools by students and teachers during industrial actions. Secondly, the task facing the subject advisors, in spite of industrial actions, was often beyond their physical means, with some circuits covering large areas due to shortages of staff (Khan 1994:27). Thirdly, most subject advisors were whites and were therefore treated with suspicion and sometimes outright rejection.

In an attempt to move beyond the self-fulfilling prophesy of educational failure, non-governmental organisations (NGOs) stepped into this gap. With regards to science education, the Science Education Project (SEP) was launched in Ciskei in 1976. It soon spread to Transkei, Transvaal, KwaZulu, Bophuthatswana, Eastern Cape, Western Cape and Bloemfontein. According to Donn (1995:205):

SEP reached 120 000 teachers in 15 000 schools. The intention was to improve the quality of teaching and promote science education in black schools by equipping schools with low cost science kits; changing teaching strategies away from rote-learning to an inquiry-based approach; and producing tested supplementary material (teacher guides and pupil work sheets). It was hoped that the science kits would allow a teacher to move from one classroom to another, so that whilst still using printed matter, both teacher and pupils would have access to the subject matter of science.

The central thrust of the SEP was teacher in-service training, and continuous school visits by SEP implementers. However, an appreciable proportion of in-service training courses fail to relate to the subject matter that is taught at any given time in schools (Gray 1989:5). Topic-specific courses often either precede or postdate the classroom programme by a long time period. This was evident in SEP programmes especially where a single SEP implementer had to cover many schools in his or her region.

In addition, the nature of the crisis in science education was so vast that no NGO in this field could claim to have reached the entire teacher cadre in its field of interest (Khan 1994:27).

Cooperation from stakeholders is imperative for successful implementation of NGOs' programmes. Some of the problems encountered by SEP were mistrust and suspicion from the stakeholders. This is highlighted in MacDonald and Rogan's (1990:130) observation that "until there is an honest and open attempt by South Africans to restructure the education system, much of the work done by SEP and other curriculum projects in the country will be limited in its impact."

### 2.4.3 INCREASED ENROLMENTS AT SECONDARY SCHOOLS

The intake of secondary school going pupils in black schools was sturdy up to the early seventies. During the sixties the policy of the government was that more secondary schools should be built in the homelands than in the urban areas (Masitsa 1995:50). This resulted in a backlog in the number of secondary schools in urban areas. The expansion of secondary school pupils in the eighties culminated in a crisis and the whole country experienced a staggering shortage of secondary schools. In 1989 there were 488 015 secondary school pupils in the DET. If this figure is compared with the 122 489 secondary school pupils in 1970, the outcome was an average annual growth of 18 276 pupils. In 1990 there were 568 920 secondary school pupils whereas in 1991 this number rose to 647 949 pupils. This represented an increase of 79 029 pupils in a year (Masitsa 1995:51).

The expansion in the number of pupils presented tremendous challenges to the DET in terms of the provision of education, particularly in the light of textbooks, prescribed books, stationary and teachers. Great shortages of these basic necessities were experienced in many schools. The existing facilities were also placed under great pressure. School administrators had to obviate this pressure by starting a platoon system (two groups of students attending classes in shifts) or forming big classes. In this regard laboratories, libraries, and other specialised classes were converted into ordinary classrooms. The practical approach to the teaching of science was therefore sacrificed. The abolition of influx control also aggravated overcrowding in that pupils left rural schools and started attending urban schools. Also, the high standard ten failure rates in the eighties, and the ensuing return of pupils to school who by right should have long left school, led to an excessive demand for accommodation in secondary schools.

To sum up, a considerable number of schools were characterized by lack of discipline, disorder and lawlessness. Scarce commodities like textbooks, laboratory equipment, electricity, *et cetera* were lost and damaged during unrest periods. The DET was then placed in a difficult position of having to provide more classrooms and also replace broken down facilities.

In conclusion, one could say that the acute shortage of secondary school buildings which resulted in schools being overcrowded had grave consequences for science education in black schools. Facilities in these schools were poor: inadequate buildings and science rooms or laboratories, textbooks were in short supply, and equipment was often lacking.

#### **2.4.4 SCHOOL ADMINISTRATION**

School administration in DET schools was vested entirely upon the principal. The other stakeholders (deputy principal, heads of departments, teachers, parents, students) were marginalised and their contribution was insignificant. As an example, the management councils (the equivalent of governing bodies in white schools) were charged by the DET to help in school administration. The principal acted as an *ex officio* member of the management council. Once elected (sometimes handpicked by the principal), the members would serve for years without reelection. The duties they expended (especially the chairperson) were to sign teachers' leave forms and forms of newly appointed teachers who were already hired by the principal, giving a speech in the odd parents' meeting, and some other trivial duties. In most cases, they would not be concerned with important day to day issues that affect the running of the school such as the timely beginning of teaching when schools reopen, the quality of teaching at the school, discipline of children, involving parents in school activities, and the like. Even the school finances were usually administered by the school (usually the principal) with little or no help from management councils. Consequently, schools were run without proper budgets being put forward for scrutiny by other stakeholders. Parents and teachers were not given proper financial statements and school funds were spent on an ad-hoc basis. This caused confusion and anger particularly amongst science teachers whose requests for replacing consumable materials were met with statements like *the school has no money*. Staff morale was therefore sacrificed.

The successful administration of a school therefore depended on the leadership quality of the principal. Successful schools were characterised by dynamic school principals capable of maintaining discipline and order, perhaps backed up by religious or ideological breaks with the numbing strictures of departmental regularities. It may well be, argues the NEPI (1992d:25) report, that poor school administration, from the organization of timetables to the review and promotion of teachers, was the single most important cause of inferior schooling in South Africa.

#### **2.4.5 INSUFFICIENT PLANNING**

The inadequacy of black schooling has many dimensions, qualitative and quantitative. An area where this was most apparent was in the provision of science and technology education. The following inadequacies, which could be ascribed to poor planning by the former government and education authorities, characterised the school system:

- (a) Nineteen racially defined government departments were responsible for their own research and development with no coherence within the system, particularly in science and technology. "In addition to departmental fragmentation, there [were] differing financing arrangements and regulations affecting various classes of education institution: departmental, state-aided, and private schools; ... " (NEPI 1992c:13). Financing nineteen departments each with its own bureaucracy was definitely not cost effective. It also gave room for bias in financing, culminating in differential financing of the education of whites, indians, coloureds and blacks.
- (b) There was no universal science and technology education at school level. Early differentiation (at standard seven) forced a Social Science - Natural Science lopsidedness. Consequently, few students chose natural sciences. This is in spite of the fact that industrial restructuring requires substantial, universal science and technology education at school level (Bawa 1994:3).
- (c) The science and technology system had no formal connections with organs of civil society. Consequently, the school science curricula were highly abstract because they were prescribed by the needs of university degrees. This is evidenced by a lack of a technology component in school courses (Bawa 1994:3).
- (d) The nature of learning/teaching at school level in the absence of proper and sufficient teacher education became heavily-dependent on rote-learning and other forms of "banking" (Bawa 1994:3).
- (e) An absence of an acceptable labour-relations policy for teachers created a volatile situation. Teachers would engage in mass actions (boycotts, chalk-downs, marches) for issues relating to the recognition of their trade union, the high number of periods they were expected to teach, and other problems relating to conditions of service (long probation periods, temporary posts, harassment by principals). Such mass actions further aggravated the culture of teaching in black schools and contributed to the falling social status of teaching as a profession and vocation (Gray 1989:10).
- (f) The lack of a structured programme for in-service training did not address the plight of unqualified and underqualified teachers. Consequently, low retention rates and massive failures characterised the education system.
- (g) Rural and farm schools, which formed a large proportion of the school-going population, were grossly neglected. Adequate funds were not channelled to these institutions and in some cases the provision of education was left at the hands of civilians (farmers). In most cases, children in these regions had no access to secondary education. According to the NEPI report

(1992c:28), over three-quarters of all Black matriculation students attended homeland schools. Mathematics and Science enrolments in these regions, however, lagged considerably behind those in urban areas. The quality of facilities and instruction in the sciences was particularly weak in these rural homelands, which were often inaccessible and increasingly ignored by policy-makers and officials.

## **2.5 BARRIERS TO PARTICIPATION BY BLACKS**

It is apparent from the foregoing that blacks are under represented in the science fields. The major cause for the low participation by blacks was ascribed to racial bias in the apartheid philosophy. Besides political factors, what was the primary factor(s) that have created and sustained this under representation in science fields by blacks? Several key variables pertaining to this question have been identified (Hill, Pettus & Hedin 1990:291-296) and are discussed below.

### **2.5.1 INTEREST AND ENROLMENTS**

A likely factor affecting the pursuit of studies in the sciences is the extent to which students actually like the subjects. According to Hill *et al.* (1990:291), it is not surprising that students who have a high level of interest in mathematics and science are more likely to pursue majors and continue with careers in those fields than are students who have lower interest levels. From studies undertaken abroad, Hill *et al.* report that race differences play a role as far as students' interest in, and affinity for, mathematics and science are concerned. In these studies blacks expressed lower levels of interest and affinity for mathematics and science than whites. The same results were found in South Africa. South African studies, however, reveal that the decline in the number of physical science students is due to the neglect of conditions which stimulate students' interest in science (Humphrey & Taole in Van der Linde *et al.* 1994:49).

It is to be expected, therefore, that the lack of interest will lead to lower enrolments of blacks in mathematics and science. The ripple effect will thus be evident in higher levels where few blacks will be found in the science fields. In the South African context, it has been shown in previous sections that blacks are under represented in science and engineering, accounting for less than 20 percent of the post secondary student population in these fields. In this regard, it can be averred that school enrolments in mathematics and science serves as a filter for tertiary studies in the sciences.

### **2.5.2 ACHIEVEMENT AND ANXIETY**

Academic ability and mastery that students exhibit have been found to influence students' enrolment in post compulsory school mathematics and science courses (Austin & Panos in Hill *et al.* 1990:292).

Investigations on the under representation of blacks (minorities) in America, as reported by Hill *et al.*, found the following:

- Under representation is partially mediated by differences in levels of developed abilities and achievement needed in the sciences.
- Black students score lower on mathematics and science achievement tests and have lower performance scores than do whites on the mathematics portion of the Scholastic Aptitude Test (SAT).
- Black students tend to have lower grades in high school mathematics and science than do whites and are over represented among students taking remedial high school mathematics courses.

Similar results have been found in South Africa. In their analysis of the crisis in science education in developing countries, Van der Linde *et al.* (1994:49) note the following:

- The pass rates are extremely low and there is a growing unpopularity of the sciences. This is not due to just one factor, but to a combination of factors which are in one way or the other associated with poor staffing and inadequate facilities in secondary schools.
- Students' mathematical background is poor and the subject matter is presented in a dull and uninteresting manner.
- Students regard physical science as a difficult subject which require mathematical knowledge and a difficult *scientific language*. As a result, standard seven students did not intend to choose physical science in their standard eight years.

There are indications that science anxiety is related to factors such as science achievement and student attitudes towards science (Chiarelott & Czerniak 1987:202). There are also reports that black students exhibit significantly higher mathematics and science anxiety than their white counterparts (Hill *et al.* 1990:292). Bearing in mind that science anxiety results in low achievement scores, this fact of higher science and mathematics anxiety among blacks could represent a serious confounding factor when interpreting achievement test data.

### 2.5.3 PERSONAL FACTORS

Interest in science careers has been closely associated with personality characteristics (Hill *et al.* 1990:292). White male science students and scientists were found to be reserved, sober, practical, authoritarian, conservative, and male sex-role oriented. Most blacks, however, differ significantly from the basic personality of white males. Since science-oriented careers are dominated by whites, such personality differences could be instrumental in the lack of participation by blacks in science courses and science careers.

Another personality factor that influence interest in science is the self-concept. Jacobowitz (in Hill *et al.* 1990:293), for example, found that the self-concept is a better predictor of science career preference than any variable other than gender. The self-concept, according to Gouws and Kruger (1994:93), influences students' social relationships, progress at school, performance in all areas, and career expectations and success. It is a frame of reference that gives meaning to perceptions and orientation to behaviour, and influences the child's level of aspiration (Searles 1963:35). As shown in previous sections, most black students regard science as a difficult subject. To pursue further studies in science, black students will need to have a particularly high level of educational and occupational aspiration. Such educational and occupational expectations have been shown to be dependent on the socioeconomic status of the family (Clifton 1978:66), with students from low socioeconomic status families having less expectations than children from high socioeconomic status families. In this regard, socioeconomic status, and not race, seems to be a critical factor as far as participation in science careers is concerned. Evidence to this effect is provided by Pearson (in Hill *et al.* 1990:294) who found that even among black scientists, the majority had their origins in families where the parents were professionals. It becomes evident, then, that the low socioeconomic status of black students represents a serious confounding factor in access to science education and science careers.

### 2.5.4 ROLE MODELS

Role models are important in enhancing participation in the natural and technical sciences. According to Hill *et al.* (1990:294), students who are exposed to, and interact with, professional scientists are reportedly eager to pursue science-related careers than students who lack such role models. These authors analysed the number of black science and engineering students produced in American universities. They found that the majority came from historically black institutions in which lecturers were mostly black. These black scientists and engineers provide visible role models for students.

As indicated earlier, there is a lack of black role models in the South African education system (from primary to tertiary level). Historically black universities are also staffed by few black professional scientists. Furthermore, all of the historically black universities do not have an engineering programme

in their curriculum. The latter are provided for in most historically white institutions which are obviously staffed by whites. It is imperative, therefore, that historically black institutions should develop engineering programmes.

Implicit in this deliberation is the fact that school teachers who are properly qualified in teaching science could act as worthy role models and as such enhance students' interest in choosing science subjects. This is hard to find especially when one considers that teaching as a profession has lost its social status. Black teachers, in particular, are not held in high esteem by both parents and students. Improving the image and social status of science teachers should be treated as a priority by all who are interested in the education of South African children.

### **2.5.5 EARLY CAREER ASPIRATIONS**

By the time students reach junior secondary school, they have already developed preferences for or against science careers. In other words, they have already formed attitudes concerning science related careers. Factors shaping such attitudes include level of aspiration, socioeconomic status, the affinity of students for mathematics and science hobbies during childhood, informal interactions with parents and older siblings (for example participating in mathematics games), and participation in school mathematics and science clubs.

It is evident that junior secondary students had already established some form of career related stereotyping. Corrective measures that will influence students' choice of a career must therefore be implemented at that early age.

## **2.6 CONCLUSION**

This chapter has shed light on physical science education in South Africa. Firstly, a case was made for science education in the curriculum. In this regard the study showed that science education is an important aspect in the education of children. As such it forms an integral part of the basic education that children receive, internationally. The literature study undertaken here has shown that school science education is important for an individual child's development. It affords the child the ability to understand basic technologies (electricity, television) and scientific phenomena (pollution, chemical hazards); that is, it makes individuals to be scientifically literate.

Science education has also been shown to benefit society in that it trains individuals to be worthy citizens who can make informed decisions on matters with a scientific or technological nature. Such active participation has been shown to be beneficial to societies founded on democratic principles.



The economic development of a country also stands to benefit from science education. The literature study has shown that technical change enhances economic growth and that scientific knowledge plays a pivotal role in technical change. Scientific knowledge is thus a necessary ingredient in economic development.

In addition, this study has shown that scientific knowledge helps in developing and maintaining modern technological innovations. Although technological innovations have historically occurred independently of scientific knowledge, modern technological innovations rely more and more on scientific knowledge. School science education is thus well positioned to fostering basic scientific literacy needed for individuals to function in a highly technocratic society.

Next, the place that sciences occupy in the South African education system was analysed. It was found that all students are supposed to study science up to standard seven. Thereafter, they may choose to continue studying science up to standard ten or they may drop it off their curriculum. In this regard, few students chose to study science after standard seven. This unfortunate situation has a snowball effect in that only few matriculants take science courses at tertiary level. Consequently, South Africa produces far fewer graduates in science and engineering as compared to other developing countries. It was shown that the low numbers of scientists and engineers impact negatively on national development.

The reasons for the low enrolment in school science are many and varied. An analysis of the South African situation, however, indicated that the bulk of the problems experienced were due, to a large extent, to segregated financing and control of schooling. The finances allocated to school education were consumed by a bureaucracy of nineteen independent departments. Consequently, resources necessary for teaching science were scarce and the default method of rote learning was of no interest to students. Adding salt to a wound, industrial actions by teachers and interruptions of schooling by pupils eroded the culture of teaching and learning. The meagre facilities which were available were often damaged and/or looted during disturbances at schools. This rendered education, particularly science education, into a crisis.

Further analysis of the crisis in science education indicated that several non-political factors contribute to low participation rates of blacks in science courses. These factors include the interest students display for science, low enrolment figures, differential academic ability amongst different races, levels of science anxiety, personal factors, career aspirations and availability of suitable role models.

In conclusion, this chapter has succeeded in proving that the situation that prevailed in many black secondary schools was not conducive to the learning of science. However, it also proved that science education, besides the problems that beset it, plays an important role in personal and national development and its worth cannot be overemphasised.

## CHAPTER 3

### THE THEORETICAL APPROACH TO THE STUDY OF SCIENCE ACHIEVEMENT AND ATTITUDE

#### 3.1 INTRODUCTION

Researchers in the field of academic outcomes, in particular science achievement and science attitude, usually follow one of two approaches in their investigations: a theoretical approach or a methodological exposition. The theoretical approach refers to studies that determine simple correlations, factor analyses, and the like. The methodological approach, on the other hand, endeavours to determine both the magnitude and direction of relationships, and makes use of complex structural equations that indicate both the direct and indirect effects among variables under investigation. In this study, the results of investigations using the two approaches are discussed since each will highlight important aspects related to science achievement and attitude. The focus of this chapter, however, is on research results using mainly the theoretical approach. The methodological approach is presented in chapter four.

The literature abounds with studies following the theoretical approach. In most cases, investigations are directed at determining the effect of one or more variables (for example, gender, ability, *et cetera*) on science achievement and/or attitude. The number of variables that have been reported as influencing science achievement and attitude are consequently large and requires a systematic way of classification.

Classifications provided in the literature, however, are not the same, differing from one author to the other (Castejon & Vera-Munoz 1996:21; Fraser, Walberg, Welch & Hattie 1987:165). This is indicative of the complex nature of determinants of science outcomes. To circumvent the classification problem, factors related to science achievement and attitude are classified in this thesis according to the title of the research, namely psychological factors and social factors.

Most investigations reported in this chapter focus on more than one variable in their design. As such the authors, besides reporting on a said relationship (say the relationship between home variables and achievement), also report on the effects of mediating variables (for example the effect of personal characteristics on the relationship between home variables and achievement). The insight gained from these interaction effects is crucial for a proper understanding of the phenomena under investigation, and forms an integral part of chapter four. The aim of this chapter, however, was to determine whether there are relationships between selected psychological and social factors and students' science outcomes. Concurrent discussion of interaction effects are, in most cases, not reported. Also, for the sake of brevity, protracted discussions on the mechanisms involved in the relationships investigated in this chapter are

avoided. This is purely for technical reasons as the large number of relationships investigated in this study would result in several volumes.

Before turning to the literature review, a few concepts used repeatedly in previous research are described. The aim is not to give a comprehensive explanation of these concepts, but to highlight critical issues that ought to be taken into cognisance in their interpretation.

## 3.2 STATISTICAL CONCEPTS USED IN RESEARCH REPORTS

### 3.2.1 THE CORRELATION COEFFICIENT

According to Anderson and Sclove (1978:183), the amount and direction of association between two numerical variables is called a correlation. The correlation coefficient is a descriptive statistic for bivariate numerical data.

Correlation studies abound in educational and psychological research. Different methods are used to calculate the correlation coefficient (represented by the symbol  $r$ ). For example,

$$r = \frac{\sum(x - \bar{x})(y - \bar{y})}{\sqrt{\sum(x - \bar{x})^2 \sum(y - \bar{y})^2}}$$

where  $\bar{x}$  and  $\bar{y}$  are the respective means of variables  $x$  and  $y$ ; and

$$r = \frac{\sigma(X, Y)}{\sigma_x \sigma_y}$$

where  $\sigma_x$  and  $\sigma_y$  are the standard deviations of  $X$  and  $Y$ , and  $\sigma(X, Y)$  is the covariance between the two variables.

One aspect that has made the correlation coefficient to be used extensively is that it is independent of the units of measures of the variables being correlated. In other words, the raw scores are standardised in the process of the calculation of the correlation coefficient (Pedhazur & Schmelkin 1991:370).

As a consequence of the standardisation of the raw scores, the maximum value of  $r$  is  $|1,00|$ ;  $r = +1,00$  means a perfect positive correlation;  $r = -1,00$  means a perfect negative correlation; and  $r = 0,00$  means no linear relation. The closer the correlation coefficient is to unity, the "stronger" the relation between the variables under consideration.

The interpretation of the correlation coefficient, however, is not that simple since there are difficulties in its application and interpretation. Aspects that are problematic in the interpretation of correlation coefficients are discussed below.

### 3.2.1.1 THE EFFECTS OF CURVILINEARITY

To illustrate the effects of curvilinearity, the following example from Pedhazur and Schmelkin (1991:37-38) is given. Consider figure 3.1 which shows a plot of the association between Anxiety (on the X-axis) and Problem Solving (on the Y-axis). If figure 3.1 (A) is to reflect the relationship between anxiety and problem solving, it would be concluded that increments in anxiety are associated with increments in problem solving! If, on the other hand, figure 3.1 (B) were to reflect the situation, then it would be concluded that increments in anxiety are associated with increments in problem solving up to an optimal point (about a medium level of anxiety), beyond which increments in anxiety are associated with decrements in problem solving. Using a Pearson correlation coefficient when data look like those in figure 3.1 (B) would result in a very low correlation coefficient, hence in an erroneous conclusion that anxiety and problem solving are not related. Clearly, the two variables are related, but the relation is not linear.

**Figure 3.1** A hypothetical association between two variables

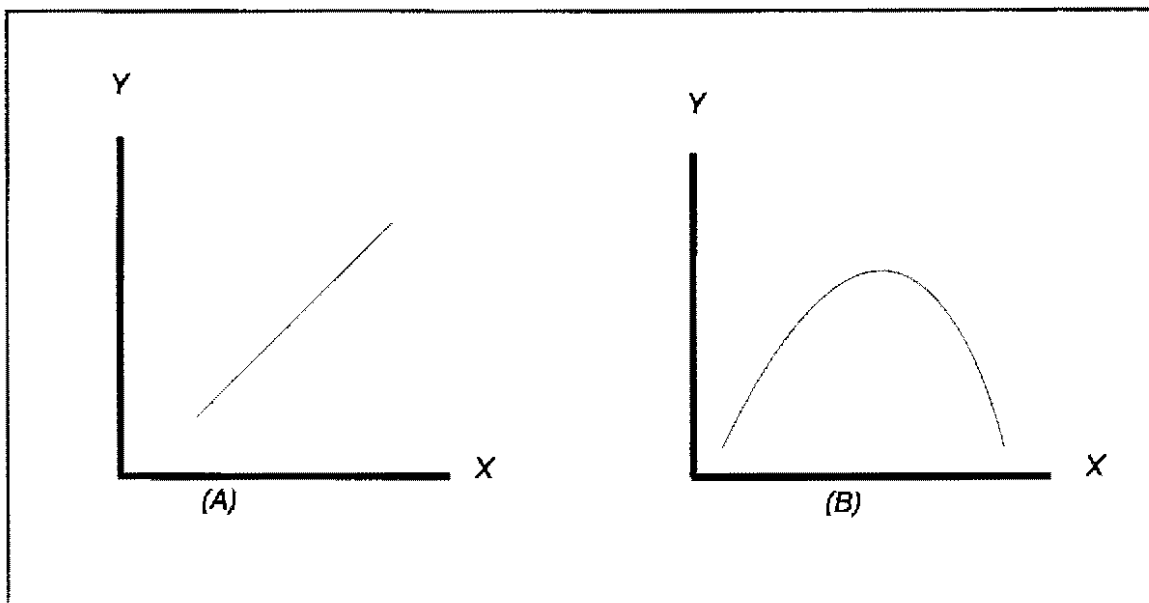

In many research reports, the test for linearity of the data is not reported. As such it becomes difficult to make judgements of whether a reported correlation is indeed low or whether the effects of curvilinearity are at play.

### **3.2.1.2 SAMPLING EFFECTS**

One of the most serious shortcomings of the correlation coefficient, according to Pedhazur and Schmelkin (1991:409), is that it is population specific. As such, the magnitude of the correlation coefficient is affected by the variability of the population from which the sample was drawn. Other things being equal, the more homogenous the population from which the sample under study was drawn, the lower the correlation coefficient.

The correlation coefficient, then, must be calculated only when data from a probability sample is available. In all other cases, the correlation coefficient should be used for descriptive purposes only in the group being studied (Pedhazur and Schmelkin 1991:409). Since some research studies make use of non probability samples (or the so-called convenience samples), their reported correlation coefficients may be low.

### **3.2.1.3 EFFECTS OF NORMALITY**

In the correlation model, both variables are random and assumed to follow a bivariate normal distribution (Pedhazur & Schmelkin 1991:409). The value of Pearson's product moment correlation coefficient ( $r$ ) is thus greatly influenced by extreme observations, and the test for significance is sensitive to deviations from normality (Freund & Wilson 1985:574). It often happens that low correlation coefficients are reported as statistically significant simply because of the large samples that were used.

To sum up, a correlation coefficient is a measure of the linear relationship between two continuous variables. The statistical theory used in the calculation of correlation coefficients dictates that certain conditions be met. Deviation from these conditions has the effect of lowering the magnitude of the correlation coefficient. Conditions that must be met in the calculation of the correlation coefficient are as follows.

- (1) Both variables must be continuous.
- (2) The sample must be selected randomly.
- (3) The variables must be linearly related.

Failure to adhere to these conditions has the effect of lowering the value of the correlation coefficient. Furthermore, failure to recognise that variables can be related exponentially (that is, not linearly) has often led to variables being regarded as not related or having a very low relationship.

When all the conditions surrounding the calculation of the correlation coefficient are taken into account, a question arises as to how the correlation coefficient should be interpreted. Before attempting to answer this question, a description of meta-analysis is provided.

### **3.2.2 META-ANALYSIS**

Educational and Psychological research usually follow one of two steps to the cumulation of knowledge:

- (1) the cumulation of results across studies to establish facts, and
- (2) the formation of theories to place the facts into a coherent and useful form.

Meta-analysis focuses on the first step - the resolution of the basic facts from a set of studies that all bear on the same relationship (Hunter, Schmidt & Jackson 1982:10-11).

According to Hedges and Olkin (1985:13), meta-analysis is the rubric used to describe quantitative methods for combining evidence across studies. It relies on "data" in the form of summary statistics derived from primary analyses of studies. By primary analysis is meant the original analysis of data in a research study.

In meta-analysis, the properties of primary research studies and their findings are recorded in quantitative terms and then subjected to numerous and diverse statistical methods (Glass, McGaw & Smith 1981:21). The end-product of such endeavours are then reported in terms of average or mean effect sizes as described below.

### **3.2.3 EFFECT SIZES**

Effect size refers to "the degree to which the phenomenon is present in the population, or the degree to which the null hypothesis is false" (Cohen 1988:9-10). A simpler definition of effect size is offered by Pedhazur and Schmelkin (1991:204). They aver that effect size refers to the magnitude of findings (for example, a correlation between two variables or the difference between two means). There exist different effect size indicators in the literature (Rosenthal 1984:38-39), each with its own merits. The most commonly used effect size indicators, however, are product moment correlations and standardised differences between means.

As shown earlier, the calculation of the correlation coefficient can be achieved through a number of ways using different formulae obtainable from any standard text of statistics. The calculation of the effect size in terms of standardised differences in means ( $\Delta$ ) can be achieved through the formula

$$\Delta = (\bar{X}(E) - \bar{X}(C))/S^*$$

In this formula:

$\bar{X}(E)$  = the mean of the experimental group;

$\bar{X}(C)$  = the mean of the control group; and

$S^*$  = the standard deviation of either the control group, the experimental group or a combination of the experimental and control group (the so-called pooled standard deviation).

Similar to the correlation coefficient,  $\Delta$  is a standardized score.

In meta-analysis, effect sizes ( $r$ 's or  $\Delta$ 's) of individual primary analyses are combined to give a final meta-analysis statistic. This final meta-analysis statistic is the average or mean of the effect sizes of primary analyses and is referred to as the mean/average correlation coefficient ( $\bar{r}$ ) or mean/average effect size ( $\bar{\Delta}$ ). In combining the results of primary analyses, several procedures that eliminate type II errors, sampling errors, and so forth, are followed (Rosenthal 1984, chapter 2). As such, the mean effect sizes reported in meta-analysis studies should not be interpreted as mere simple averages of the correlation coefficients or the standardised mean differences ( $\Delta$ ).

According to Hedges and Olkin (1985:76-77), an effect size ( $\Delta$ ) of 0,5 implies that the score of the average individual in the experimental group exceeds that of 69 percent of the individuals in the control group. Similarly an effect size of -0,5 implies that the score of the average individual in the experimental group exceeds that of only 31 percent of the individuals in the control group. Another interpretation is obtained by converting  $\Delta$  to an estimate of the correlation coefficient. When so converted, small correlation coefficients correspond to a substantial change in the success rates between the experimental and control groups. For example, a value of  $r = 0,32$  (accounting for "only" 10% of the variance), corresponds to a sizable increase in the success rate from 34 to 66 percent. Rosenthal (1984:129-132), a proponent of the above convention, argues that interpreting effect sizes in terms of the "success rate" they produce is more practical than other conventions which uses conventions of "high", "low", *et cetera*.

Commenting on the latter conventions, Pedhazur and Schmelkin (1991) offered the following caution.

The fact that an informed decision about effect size in socio behavioural research is frequently a very difficult, even unattainable, goal has prompted various authors to propose conventional effect sizes. As such, conventions for small, average, and large effect sizes for correlations, differences between means, and so forth, have been devised. ... This is an operation fraught with many dangers: the definitions are arbitrary, such qualitative concepts as "large" are sometimes understood as absolute, sometimes as relative; and thus they run the risk of being misunderstood. ... Proposals of conventional effect sizes tend to blur the distinction between magnitude of effect and its substantive importance. What is deemed "strong" or "large," say, tends also to be interpreted as "important" "meaningful." As such conventions of effect size have the unintended effect of deflecting researchers' attention from the need to come to grips with the problem of what is a meaningful effect size in a given context, for a given study (Pedhazur and Schmelkin 1991:204-205).

In view of the problems highlighted above, and bearing in mind the descriptive nature of this chapter, the judgement as to whether a particular correlation coefficient is low or high, important or not important, and so forth, are not entered into in this chapter. Such matters are dealt with in the chapters that follow. In this chapter, the focus was on determining, from previous research, the most important factors related to secondary school students' science outcomes. A description of the factors involved, their nature, and the order of magnitude found in the primary analyses are given.

### **3.3 PSYCHOLOGICAL FACTORS RELATED TO SCIENCE ACHIEVEMENT AND ATTITUDE**

#### **3.3.1 ORIENTATION**

Factors depicted as psychological include all aspects relating to the child's psyche. In other words, all variables that are personal in nature. Such factors are classified in the literature as student characteristics, self variables, personal factors, affect variables, and the like. Each of these broad categories are then sub-divided into a number of factors. From the literature consulted, the following factors featured the most: the student's ability, gender, race, self-concept, motivation, subject preference, intentions for further study, career aspirations, and attitude towards science. In the following sections, each of these factors are discussed.

#### **3.3.2 THE STUDENT'S ABILITY**

Van den Aardweg and Van den Aardweg (1993:5) defines ability as a physical or mental power or faculty which develops gradually over the years enabling an individual to deal effectively with his environment. A person's ability has, over the years, been equated to his or her intelligence. Intelligent individuals were viewed as having higher abilities than less intelligent individuals. As such, various theories of intelligence has evolved, ranging from conceptions that intelligence is what intelligence tests measure to views of intelligence as a multi-dimensional construct (Eggen & Kauchak 1997:106-117).



In the literature, several concepts are used almost synonymously with ability. For example, aptitude, formal or abstract thought, and so forth. Also, different forms of ability are distinguished, namely verbal ability, cognitive ability, psychomotor ability, and so forth.

Ability is thus a theoretical construct (latent variable) that could be measured by means of one or more observable variables (indicator variables). For a detailed description of latent and indicator variables, see chapter four.

Intuitively, it could be expected then that higher levels of cognitive ability should be associated with higher levels of achievement in science. Several studies confirm this association. Fleming and Malone (1983:483) reviewed the literature for studies of the relationship between students' abilities and their performance in science courses. In comparison to other factors such as socioeconomic status, gender and race, the results of their review (meta-analysis) revealed that general ability ( $\bar{r} = 0,43$ ), language ability ( $\bar{r} = 0,41$ ) and mathematics ability ( $\bar{r} = 0,42$ ) have the strongest positive relationship to performance on science achievement measures. In a similar meta-analysis study, Steinkamp and Maehr (1983:385) found that the correlations between achievement and cognitive ability were positive for boys ( $\bar{r} = 0,36$ ) and for girls ( $\bar{r} = 0,32$ ). Oliver and Simpson (1988:146) also referenced earlier studies bearing evidence that mathematics aptitude is related to science achievement. The relationship between students' ability and achievement in science is so great that the perception they hold with regard to their academic ability (that is, their self rating) could serve as the best single predictor of science achievement (House 1993:159).

The discourse above indicates that students' abilities (viewed as learned capabilities) play an important role in their achievement in science courses. There exist, however, another way of measuring ability that is based on the Piagetian phases of human development (Rutherford & Watson 1990:355; Menis & Fraser 1992:133). Secondary school students are expected, according to this model, to be at the formal operational level which is characterized by abstract formal reasoning. Accordingly, the modern physical science curriculum emphasises theoretical aspects which require abstract formal reasoning (for example, the mole concept, the proportion concept, Le Chatelier's principle, *et cetera*). This is in spite of the fact that approximately only fifteen to thirty percent of the upper secondary student population usually have a completely functional capacity in this level of thinking (Menis & Fraser 1992:133).

Researchers who use the Piagetian model usually measure students' abilities to perform various Piagetian tasks and then relate these scores to course achievement or other measures of student ability. The relationships that are reported in such investigations show correlations of about 0,47 (Fraser et al. 1987:178). The implication is that students who are able to think abstractly are better equipped to perform well in school physical science than their less endowed counterparts. In black education, cognitive deprivation, language inadequacies, and scholastic backlogs (Botha & Cilliers 1993:55) have

resulted in a large proportion of secondary school students who are incapable of formal operational thinking. As such, their performance in matriculation physical science is low when compared to white South African students.

Turning to the relationship between ability and attitudes toward science, inconsistent results were found in the literature. Oliver and Simpson (1988:151) reported that students who scored two letter grades higher in science than in mathematics expressed more positive attitudes toward science than students who performed the same or lower in science than in mathematics. Fleming and Malone (1983:483) reported a low mean correlation ( $\bar{r} = 0,15$ ) in measures of ability with students' attitudes toward science. On the other hand, Greenfield (1996:907-8) found no main effects in the perceptions students have about their personal ability and achievement in science. Simpson and Oliver (1990:7) argued that "average students" are often neglected when superior students or those in need of special help receives additional attention. As such the attitude towards science of the general (middle ability) group declined more rapidly than that of the advanced or basic groups.

To sum up, students' abilities are related to their performance in school physical science, irrespective of the manner in which such abilities are measured. That is, irrespective of whether ability is seen as learned capabilities or as the level of intellectual development according to the Piagetian model. Furthermore, the poor performance of black South African students in matriculation physical science could be attributed, among others, to their failure to develop abstract thinking skills. Finally, studies which investigated the influence of ability on attitude towards science yielded no clear-cut results. Of the studies that found a positive relationship, the reported correlation coefficients were very low.

### **3.3.3 THE STUDENT'S GENDER AND RACE**

Females and blacks are generally under represented in the sciences (Lees 1994:74; Tamir 1989:32; Jovanovic, Solano-Flores & Shavelson 1994:352; Greenfield 1996:901). The question could be asked whether the low participation rate of blacks and females in science is probably caused by their low achievement in the sciences or probably because they have negative attitudes toward science? In the following two subsections, the answers to these questions were sought by focussing on the effects of gender and race on the achievement of students in science and their attitudes toward science, science courses and science careers.

#### **3.3.3.1 GENDER AND RACE DIFFERENCES IN SCIENCE ACHIEVEMENT**

The observation that females and blacks are under represented in the sciences has led researchers to investigate whether there are differences in the achievement of boys and girls, and blacks and whites.

Some studies used standardised mean differences ( $\bar{\Delta}$ ) as a measure of the effect size whereas others made use of correlations ( $r$ ).

Studies that reported standardised mean differences, say for gender, mainly made use of the following conversion:

$$\bar{\Delta} = \text{mean of the boys minus the mean of the girls divided by the standard deviation of the girls.}$$

A positive value of  $\bar{\Delta}$  thus represented higher achievement (success rate) by boys and a negative value represented higher achievement (success rate) by girls.

Using the  $\bar{\Delta}$  statistic, effect sizes of 0.23, 0.16 and 0.16 were reported respectively by Lee and Burkam (1996:630), Becker (1989:156), and Fleming and Malone (1983:487). These studies indicate that males score higher than females on science achievement measures. Correlation studies also report higher achievement by boys than girls in physical science courses (Simpson & Oliver 1990:7; Schibeci & Riley 1986:183; Steinkamp & Maehr 1983:382). In other words, the boys-physical science achievement correlation is higher than the girls-physical science achievement correlation.

Turning to race, a standardised mean difference of 0.42 was reported by Fleming and Malone (1983:487), with blacks scoring lower than whites. The difference in the achievement of blacks and whites is thus quite larger than the difference in the achievement of boys and girls. In other words, differences in physical science achievement are more pronounced for race than for gender.

Similar results were found by Greenfield (1996:907-929). In her study on gender, ethnicity, science achievement and attitudes, she found that gender differences, although statistically supported, were quite small and varied with ethnicity, culture and time. Furthermore, ethnicity had a greater impact than gender on science achievement. Greenfield also found an ethnic difference in the perceptions students have concerning science and science careers. Specifically, Hawaiians were negative and Japanese students were positive. In addition, Hawaiians occupied not only the lower achieving academic strata but also the lower socioeconomic occupational strata. They are over represented in the service and blue-collar occupations and under represented in the professions and state government. These factors, avers Greenfield, influence students' attitudes toward school as well as their achievement in it. As an example, Hawaiians are reported to have the lowest attitudes and lowest achievements.

The Hawaiian context seems similar to the South African context. In South Africa blacks, in general, not only achieve lower than whites in science courses, but they also hold low socioeconomic jobs. For example, du Toit, Lachmann and Nel (1991:52) reports that grade nine to eleven Afrikaans speaking pupils received education of a high standard in chemistry and that the teachers were positive towards

chemistry. Consequently, the students sampled saw chemistry as an interesting subject. In contrast, black education, and science education in particular (see chapter two) have been reported to be of a low standard - a possible causal factor for the low socioeconomic status and occupational status of blacks.

Besides race and ethnicity, the relationship between gender and science achievement is also influenced by the content area. In a study investigating the effects of the home and the school on science achievement, Tamir (1989:36) found practically no difference in the achievement of boys and girls in biology and chemistry, although boys achieved considerably better than girls in physics. In another study, Tamir (1991:36) found that the functional knowledge of physics is influenced by gender whereas no effect was found on knowledge of biology. Steinkamp and Maehr (1983:382) also reported that boys outperform girls in physics more than in chemistry and biology. In a reanalysis of this meta-analysis study carried out by Steinkamp and Maehr, Becker (1989:162) concludes that "the preponderance of evidence in these studies suggests that gender differences in science relate to the subject matter that is being tested, ... the results suggest that physical and biological sciences and general science show the greatest discrepancies in achievement-test performance according to gender". Among others, the reason why girls achieve poorly in physical science tests could therefore be attributed to their under-performance in the physics section of the tests.

### 3.3.3.2 GENDER AND RACE DIFFERENCES IN ATTITUDE TOWARDS SCIENCE

In the case of attitude towards science, there appears to be a range of conflicting reports, especially when individual studies are examined. Studies that examine science in general, rather than a specific discipline, suggest that boys have more positive attitudes than girls. Using thirty one independent studies in a meta-analysis study, Weinburgh (1995:392) found that boys have a more positive attitude towards science than girls ( $\bar{\Delta} = 0,20$ ). MacMillan, Widaman, Balow, Hemsley & Little (1992:48) found that females expressed less favourable attitudes toward science than did males. Females, however, expressed more favourable attitudes toward reading. Simpson and Oliver (1990:7) found that males possessed significantly more positive attitudes toward science than females although the latter were significantly more motivated to achieve in science. In their meta-analysis, Fleming and Malone (1983:488) reports that males have more positive attitudes toward science than females ( $\Delta^- = 0,18$ ) at elementary and high school ( $\bar{\Delta} = 0,12$ ). During middle school level, however, girls outperform boys on science attitude measures ( $\bar{\Delta} = -0,11$ ).

This finding is in contrast to the finding of Steinkamp and Maehr (1983:383) who reports that junior high school boys' affect scores are more positive than junior high school girls' scores. Weinburgh (1995:388) cited several studies providing further evidence that boys exhibit more positive attitudes toward science than girls.

Studies that examine specific disciplines of science, on the other hand, indicate differential results. According to the meta-analysis results of Steinkamp and Maehr (1983:383), girls have more positive attitudes than boys in biology and chemistry but not in physics. Fleming and Malone (1983:490) reports that males' attitudes toward science are more positive than females' attitudes in general science classes ( $\bar{\Delta} = 0,37$ ). In chemistry and physical science, males' and females' attitudes seem about the same. Weinburgh (1995:392) reported that boys show more positive attitudes toward science than girls in general science ( $\bar{\Delta} = 0,34$ ), physics ( $\bar{\Delta} = 0,12$ ) and biology ( $\bar{\Delta} = 0,03$ ).

Rennie and Punch (1991:200) found no gender differences for the affective and achievement variables in a sample of grade eight Australian science students. Greenfield (1996:907) also found no gender differences in attitudes toward science whereas Steinkamp and Maehr (1983:383) argued that the influence of gender on affective variables is negligible.

In other studies, the authors examined gender differences on specific affective aspects. Handley and Morse (1984:606) is of the opinion that attitudes are related to gender role perceptions of male and female adolescents. Greenfield (1996:909-12) found that (1) boys expressed much more male-stereotyped views of science than girls, (2) boys expressed more physical science prior experiences with science activities than girls, and (3) girls enrolled more for advanced science and mathematics courses than boys. Banu (1986:197) also found that:

- (1) Nigerian male students enjoy science and science lessons more than female students;
- (2) female students show less positive attitudes towards social implications of science than do male students;
- (3) male students are more interested in pursuing careers in science than do female students; and
- (4) male students show more positive attitudes toward spending their leisure time working on science related activities than female students.

A surprising aspect of Banu's (1986:198) finding is that the sample he used (made up of black Nigerian children) expressed positive attitudes toward science. On a five-point scale the mean was 4.07. A similar finding was reported by MacMillan et al. (1992:48). Using a sample made up of Anglo American students and Black American students, they found that attitude scores of Black students were significantly higher than for Anglo students. In explaining this finding, the authors pointed out that the sampled Black children's achievement in science was comparable to that of Whites, hence their higher attitudes toward science. However, in South Africa, Maqsood and Khalique (1991:382) found that black children expressed positive attitudes towards mathematics (scoring 70% in an attitude towards mathematics test) even

though their achievement in mathematics was low (scoring only 44% in their end of the year promotional examination in mathematics). A favourable attitude, it seems, does not necessarily translate into higher achievement. Other variables (like ability, home and school climate, motivation, *et cetera*) are also necessary to effect high achievement.

### 3.3.3.3 SUMMARY

It has been shown that gender differences exist in science achievement. Such differences, however, are small in comparison to effects due to race or ethnicity. Also, such differences are not universal, but depend on other factors such as the particular science subject, race, socioeconomic status, time and the like. Of particular importance to this study is the finding that girls perform lower than boys in physics which (together with chemistry) forms the school subject physical science in South African schools.

Research findings reported in this section indicates that gender has an influence on attitudes toward science, with boys showing more positive attitudes than girls. The reported gender differences, however, are quite small. Few studies reported negligible or no gender differences. Conflicting results were found when attitudes toward specific subjects were examined. The reported findings seems to indicate that girls express more positive attitudes toward biology and chemistry whereas boys express more positive attitudes than girls in physics and general science. Also, black children tend to express more positive attitudes towards science than could be expected from their achievement results.

### 3.3.4 SELF-CONCEPT

Various definitions of self-concept are found in the literature. Gage and Berliner (1992:157) defines self-concept as "the totality of the perceptions that we have about ourselves - our attitude towards ourselves, the language we use to describe ourselves". The self-concept also determines an individual's relationships and generally directs the individual's experience of life events (Gouws & Kruger 1994:91). According to van den Aardweg and van den Aardweg (1993:193), the self-concept is made up of three mutually dependent components: identity, action, and self-esteem. Self-esteem, according to Ma and Kishor (1997:113), is a fragile and changing thing. It alternates from being an extremely personal phenomenon related to past happenings to being a present construct of social feedback from others. It is an outcome of action as well as the motivation for it (Solomon 1996:38). Castejon and Vera-Munoz (1996:22) view the self-concept as a multidimensional, independent variable that is related to both intelligence and motivation and that correlates significantly with academic achievement. Handley and Morse (1984:606) also argues that the self-concept correlates significantly with students' attitudes.

Recent research results in the field of self-concept indicate the following (Marsh & Yeung 1997:41; Ma & Kishor 1997:91-93):

- Self-concept possesses academic and nonacademic components and these need to be separated in any investigation. In other words, there is a difference between academic self-concept and general or global self-concept.
- Academic achievement is substantially related to academic self-concept but almost unrelated to global and nonacademic components of self-concept.
- Specific components of academic self-concept are distinct. For example, there is a science self-concept and an English self-concept.
- Academic achievement also displays domain specificity. In other words, academic achievement in one particular area should be highly correlated only with academic self-concept in that area. For example, mathematics achievement correlates substantially with mathematics self-concept, and correlates less with reading self-concept, but correlates very low with self-concept in nonacademic areas.
- Self-concept becomes increasingly multifaceted with age. That is, as students progress through their junior and senior high school years, their self-concept declines.

Marsh (1991:322), using data collected in the High School and Beyond Project, pointed out the importance of academic self-concept as both an outcome variable and a mediating variable. In particular, he argued that prior academic self-concept affects subsequent school grades beyond what can be explained by prior school grades and performance on standardized achievement tests. Part of his argument runs as follows. First, students who had part-time jobs during the last two years of high school were found to achieve poorly in comparison to students who had no part-time jobs. This is attributed to the negative effects that part-time employment has on academic self-concept. Second, students who participated in sport activities performed better due to the positive effects that participation in sports has on academic self-concept. Marsh is of the opinion that academic self-concept reflects in part an orientation or commitment to school. A student with a better academic self-concept is likely to achieve more positive academic outcomes than can be predicted by the student's ability and other background variables.

In a study investigating the influences of attitude towards science, achievement motivation, and science self-concept on achievement in science, Oliver and Simpson (1988: 150) found that science self-concept is an important predictor of achievement in unified science and chemistry taken by students in the 11th grade. In addition, students who scored two letter grades higher in science than in mathematics reported higher science self-concepts. Tamir (1991:30) also found a weak but consistent superiority in science achievement of students who hold a high self-concept as science achievers. Simpson and Oliver

(1990:5) demonstrated that the relationship between science self-concept and attitude towards science is strong. They showed that a combination of science self-concept, science anxiety and achievement motivation accounted for fifty five percent (55%) of the variance in attitude towards science.

Oliver and Simpson (1988:150) reported that mathematics achievement correlates strongly with science self-concept. This finding, they aver, is not surprising if one considers the degree of mathematics skill required in many physical science courses. It could be expected, then, that the self-concept-achievement relationship in mathematics should be similar to the self-concept-achievement relationship in physical science. Ma and Kishor (1997:99) investigated the relationship between self-concept in mathematics and achievement in mathematics in a meta-analytic review. They reported that the correlation between self-concept and achievement was statistically significant from zero ( $\bar{r} = 0,23$ ,  $p < 0,05$ ), was similar for male and female students, varied as a function of time, and the self-concept - achievement correlation for whites ( $\bar{r} = 0,44$ ) was stronger than the self-concept - achievement correlation for blacks ( $\bar{r} = 0,09$ ).

To sum up, academic self-concept, in particular science and mathematics self-concept, correlates positively with science achievement and attitudes. In other words, science self-concept accounts for an appreciable amount in the variance of science achievement and attitude measures. In addition, self-concept has an important mediating effect on the motivation of students, an aspect which is discussed in the next section.

### 3.3.5 MOTIVATION

Just like self-concept, the literature abounds with definitions or explanations of motivation. Two characteristic definitions are given below. According to Gage and Berliner (1992:326), "motivation is what moves us from boredom to interest. It is what energizes us and directs our activity.... Energy and direction are at the centre of the concept of motivation". In terms of learning, motivation could be seen as a student's tendency to find academic activities meaningful, worthwhile and academically beneficial (Caldwell & Ginther 1996:144).

Motivation correlates positively with academic achievement (Castejon & Vera-Munoz 1996:22), accounting for seven percent (7%) of the variance in a science cognitive test (Napier & Riley 1985:379). Simpson and Oliver (1990:13) found that motivation to achieve in science was consistently higher among girls and dropped both within each grade and across grades six to ten. By the tenth grade, motivation to achieve was near neutral. Achievement motivation is also an important predictor of achievement in chemistry for students in grade eleven and twelve (Oliver & Simpson 1988:150). Since motivation to learn can be influenced by the perception that students have about their own academic achievement, motivation is related to the self-concept which in turn is related to attitude towards science.



According to Solomon (1996:38), basic motivation theory assumes that students may perform for either intrinsic reward (internal satisfaction obtained from the task itself) or extrinsic reward. Extrinsic reward may vary from success in an examination to the offering of, say sweets, to small children when they get a sum right. Extrinsic reward, however, does not always produce an increased motivation in students. A student who is intrinsically motivated might find continuous extrinsic rewards repulsive and this might actually decrease his or her motivation.

Solomon (1996:38) further links intrinsic and extrinsic motivation to specific study strategies. Students who intend to gain real satisfaction from science (intrinsic reward) will strive to look for conceptual connections and meaning. Rote memorization, on the other hand, may help the student to gain external rewards in terms of passing, for example, a multiple-choice examination, but will not bring internal satisfaction in the subject. In a study investigating the learning strategies of first year chemistry students, Postma (1993:102-102) found a marked difference in the knowledge and use of learning strategies between high and low achievers in chemistry. Good learners were found to have a variety of learning strategies which they could use for attaining the learning goals.

Learners, however, can know everything about learning strategies but not use them, simply because they are not motivated or lack procedural or conditional knowledge of learning strategies (du Toit & Lachmann 1997:41). On the other hand, motivation causes the learner to concentrate on the learning task at hand and to persist in it. When exposed to suitable learning strategies, motivated students are willing to make use of such strategies (du Toit & Lachmann 1997:41). This has implications for academic achievement. For example, Reynolds and Walberg (1991:97) found that achievement is affected by concentration as a learning strategy while du Toit and Lachmann (1997:41) reported that various types of learning strategies correlate significantly with academic achievement. Since learning strategies can be taught it could be beneficial for the academic achievement of students if the instruction of learning strategies is included in the curriculum and instruction of physical science (Postma 1993:103).

According to research findings reported by Caldwell and Ginther (1996:144), the motivation to learn is governed by cognitive and affective components which guide and direct behaviour. Based on this framework, the motivation to learn can be described in terms of achievement goals. The latter are themselves divided into two contrasting constructs: performance goals and mastery goals. Individuals pursuing performance goals are concerned with receiving positive judgement of their ability. They tend to attribute success to factors outside of themselves and they believe they have no control over their performance and the events in their lives. This frequently leads to lowered motivation. Mastery-oriented students, on the other hand, pursue learning goals directed toward increasing their competence. They associate success with effort and attribute failure to lack of effort. They provide self-praise and encouragement and hence are highly motivated. In terms of control, these students see themselves as having a high level of control and hence are intrinsically motivated to learn.

Woolnough (1997:70-71) is also of the opinion that educators and researchers must concentrate more on the students, to find out what motivates them. He categorized students into four groups: achiever students; curious students; conscientious students; and sociable students. Each of these students are persuaded, respectively, by the motivational need to achieve, the need to satisfy curiosity, the need to discharge a duty, and the need to affiliate with other people. The achiever and conscientious students, for example, will need the satisfaction and security of having all their written work of a high standard, well presented and correct. Others, the curious students, will often want to play around with the apparatus, to shoot off on unintended tracks, and then not bother to write up their work satisfactorily. Students' motivation to study science are thus different and there is no one, single approach that will motivate all students. Based on these observations, Woolnough recommends two approaches that may be followed to meet individual students' needs and strengths.

The first approach uses a wide range of teaching and learning strategies in the hope that each student will find some opportunities and strategies to which they respond particularly well. The second approach sounds much like cooperative learning. It involves the setting of broad targets that are acceptable to all and to which all students are motivated to want to achieve. Then the students are provided with space and freedom to tackle those targets as they find best for themselves.

### **3.3.6 SUBJECT PREFERENCE, INTENTIONS FOR FURTHER STUDY AND CAREER ASPIRATIONS**

Course taking (enrollment in a choice subject), according to Lee and Burkam (1996:615), is the most common school related predictor of achievement in mathematics and science. The effect in science, however, is smaller than in mathematics. In a study investigating factors influencing the attitude of Afrikaans-speaking high school and university students towards chemistry, du Toit et al. (1992:263) found that twenty five percent (25%) of the students sampled were interested in chemistry as a career. The sample included students from standard seven up to chemistry I. An earlier study by the same authors, du Toit et al. (1991:52), revealed that 34% of grades nine to eleven students were interested in making chemistry a profession.

Research findings (Lee & Burkam 1996:616; Tamir 1987:92) has shown that intentions to study science further and electing a science related career are positively correlated with achievement. Deboer (1987:533) demonstrated that the intention to take more chemistry in subsequent years was directly related to students' expectations for success. Also, students who rated themselves high as far as their ability is concerned displayed higher expectations. Subject preference also influence student achievement in that particular subject. For example, Tamir (1991:27) found that students who prefer physics achieve high in physics and chemistry and those who prefer chemistry achieve high in chemistry.

He also found that students who aspire for further science study and for science careers exhibit substantially higher functional knowledge and understanding in all science areas.

Subject preference, intentions for further study of science courses and career aspirations, on the other hand, are influenced by a variety of factors. The first factor is previous science achievement. Tamir (1987:90) reports that students with higher achievement in the sciences tended to elect a future career in science, medicine, agriculture and technology more than low achievers. The latter preferred the humanities or administration. Also, students who achieved high in biology and chemistry tended to elect careers in science and medicine, while those who achieved high in physics elected careers in engineering and technology.

The second factor is the science self-concept. According to Simpson and Oliver (1990:13), science self-concept at the tenth grade level is a good predictor of both number and type of science courses a student will take during high school. In particular, students with lower attitudes do not appear to pursue additional courses in science.

Other factors include attitudes and aspirations, cultural values and parental influence and support. These factors have been shown to influence the career choice of blacks by Ascher (Germann 1994:750). In a study investigating factors affecting the attitudes of blacks and females toward the pursuit of science-related careers, Hill, Pettus and Hedin (1990:306-8) concluded that:

- (1) The critical variable for females is a lack of science career interest - a product of socialization. To overcome this barrier, existing sex stereotypes and the masculine image of science held by teachers, parents and students themselves need to be challenged.
- (2) Role models (that is, personal contact with a scientist) influence students' pursuit of careers in science and science-related fields.
- (3) Critical thinking ability is a major barrier for blacks in terms of participation in science courses. To overcome this barrier, enrichment programs and credit-bearing courses on critical thinking that emphasize process rather than content could be implemented in schools and universities.

Du Toit et al. (1992:261) argues that "the perceptions and attitudes developed during the chemistry course determine the degree of motivation with which students study and whether they will pursue chemistry as a career and occupation after their studies have been completed." According to Woolnough (1997:69) there are six factors that influence students' continued participation in science courses and careers. Since students are not the same, different factors tend to influence individual students differently. These factors can be grouped into two divisions, the out-of-school factors and the in-school

factors. The out-of-school factors relate to (1) job opportunities, job satisfaction and job status in science and technology, (2) ease of access and attractiveness of science and engineering courses in higher education, and (3) the home background of the students, the influence of their close relatives and their hobbies. In-school factors include (4) science teachers, (5) science curriculum, and (6) extra-curricular science activities.

### 3.3.7 ATTITUDE TOWARDS SCIENCE

Although attitude development is certainly secondary to academic achievement in the schools, it can be argued that attitude toward school subjects is itself an important and desirable educational outcome (Myers & Fouts 1992:929).

The significance of research into the affective domain (covering students' perceptions, attitudes, interests and motivation) gained momentum after Bloom published a book in 1976 with the title: *Human characteristics and school learning*. In this publication, Bloom (in Simpson & Oliver 1990:1) asserted that the affective variables accounted for twenty five percent (25%) of the variance in students' academic achievements. Since then, various reports appeared arguing that affective variables (attitudes) are important educational outcomes (Tocci & Engelhard 1991:280; Misiti, Shrigley & Hanson 1991:525; Oliver & Simpson 1988:154; Weinburgh 1995:387; Mordi 1991:39; MacMillan et al. 1992:40; Koballa 1992:63-64; Schibeci & Riley 1986:185).

Among others, the reasons forwarded for the study of attitudes are as follows. First, science attitudes, as shown below, are related to science achievement. Second, students with a positive attitude towards, say science, are more likely to pursue further studies and careers in science (see section 3.3.6). Also, for those students who do not intend to pursue higher education, they may learn science informally. This has important implications for the country as far as scientific literacy is concerned (see section 2.2.1.1). Third, attitude is often communicated to peers in a variety of ways throughout life. For example, in chapter two it was shown that black students regard science as a difficult subject, and as such only a few black students enroll for science past the compulsory level. Consequently, such negative attitudes lead to a lack of support for science and this impacts the country's development negatively. According to Simpson and Oliver (1990:7), friendships are important for students and as such group norms have the ability of accelerating either an upward or downward spiral of attitudes toward science.

There is thus sufficient evidence to support the significance of positive attitudes in education, particularly in science. Given the importance of attitudes as indicated above, do attitudes toward science correlate significantly with science achievement?

Several studies have investigated the relationship between attitudes toward science and science achievement. Tamir (1987:92), in a study investigating factors which affect science achievement of high

school seniors in Israel, found that students' attitudes toward science are positively correlated with achievement. Simpson and Oliver (1990:7-13) carried out a longitudinal study of major influences on attitude toward and achievement in science among adolescent students. The first wave of data (1980-1981) revealed that the combined effect of science self-concept, science anxiety, and attitude towards science accounted for as much as eleven percent of the variance in science achievement. Subsequent waves of data were collected and after ten years the authors observed that: "How students feel toward science and their ability to succeed in science at the tenth grade level is a strong predictor of subsequent science achievement in high school. Data from this longitudinal study support a stronger attitude-achievement relationship than do prior reports". Rennie and Punch (1991:206) found that students' perceptions of their past performance in science form the most important component variable of science-related affect associated with both previous and subsequent achievement. For example, the variance in subsequent achievement that could be explained for by affective factors in one school that they investigated ranged from twenty six percent (26%) to forty percent (40%).

A meta-analysis of studies of the relationship between science achievement and science attitude from kindergarten to college reported a mean correlation of 0,16 (Wilson 1983:641). Another meta-analysis (Steinkamp and Maehr 1983:385) reported mean correlations of 0,19 for males and 0,18 for females between affect and science achievement.

Other studies examined the relationship between attitude towards science and achievement in science by gender. In her literature review, Weinburgh (1995:388-9) cited two studies, one by Stoner and another by Cannon. The former found the attitude-achievement correlation to be stronger for girls than boys while the latter found the correlation to be higher for basic and advanced-performance girls and general performance boys. In her own meta-analytic investigation, Weinburgh (1995:392-3) reports mean correlations of 0,50 for boys and 0,55 for girls, indicating that for both boys and girls there is a strong, positive relationship between attitude towards science and achievement in science. The relationship is stronger for girls than boys. Weinburgh further determined the correlation between attitude and achievement for boys and girls as a function of science type (biology and physics). She found that for each discipline, the correlation is positive and slightly stronger for girls than boys. The correlation is also higher in biology than in physics but in each case, students with a more positive attitude towards the science type investigated showed greater achievement.

A closer look at the results of research reported above indicate that earlier studies tend to report lower correlations than recent studies. This could be attributed to the increased knowledge that is now available concerning theoretical and measurement issues in attitude research. Previously, researchers did not properly operationalize either or both attitude towards science and science achievement (Rennie & Punch 1991:194; Germann 1988:690). Of importance, however, is that there is a correlation between attitude towards science and science achievement, and that the correlation seems to be more stronger

between attitudes towards a particular subject (for example biology or physical science) and achievement in that subject, rather than in all science subjects.

Another aspect of the attitude-achievement relationship involves the direction of the relationship. This aspect will be investigated closely in chapter four but two opposing views are given below. A study by Rennie and Punch (1991:207) revealed that science-related affect (attitude) is more closely related to previous achievement than to subsequent achievement. In other words, there is a stronger influence by achievement on later affect than by affect on later achievement. Contrary to this, House (1993:159) reports that college students' initial attitudes are significant predictors of subsequent achievement in first year science.

### **3.3.8 SUMMARY**

In the sections discussed above, several psychological factors which influence science outcomes (that is, achievement and attitudes) were identified, namely ability, gender, race, and affective variables. The affective variables investigated included the self-concept, motivation, attitude, preferences and aspirations. Each of these factors were shown to influence science outcomes significantly.

The child's ability in physical science seems to have a higher influence on science achievement than the other factors when the correlation coefficient is used as a standard of comparison. Ability, however, is not a good predictor of science attitudes. Significant gender differences favouring males were found for both science achievement and science attitudes. The differences, however, were very small. Some authors even contend that such differences are negligible, requiring no further investigation.

Affective factors, on the other hand, influence science outcomes significantly even after the effects of ability have been eliminated. Although each affective variable influence science outcomes positively, their combined effect is even more pronounced. This finding is particularly important since it implies that affective factors, attitudes in particular, play a crucial role in the education of children. In other words, educators cannot afford to neglect children's attitudes in any educational programme. And since attitudes are influenced by significant others, the role of socializing agents (parents, siblings, teachers, friends) is important and also needs attention.

## **3.4 SOCIAL FACTORS INFLUENCING SCIENCE ACHIEVEMENT AND ATTITUDE**

### **3.4.1 ORIENTATION**

Factors depicted as social include those related to the child's socialization. Through socialization, the child learns the culture, attitude, norms and values of the group or society (Mashile 1995:14) and also

how to be engaged in social relations (Kuper & Kuper 1985:794). Persons, institutions and groups that are in continual contact with the child will therefore influence the child's socialization process. As such, the influence of the family and the school (as socialisation agents) on students' science achievement and science attitudes are presented in the following sections.

### **3.4.2 THE FAMILY**

The family plays an important role in determining the academic achievement (Castejon & Vera-Munoz 1996:22) and attitudes (Simpson & Oliver 1990:6) of children. Researchers have identified family variables that could possibly explain how the family influence certain aspects of the child's functioning. These family variables include family structure, parents' occupation and education, parental socioeconomic status, parenting styles, parental beliefs, parental involvement and support in school-related matters and the perceptions children themselves have about such involvement and support. Most researchers only ascribe a few of these variables as familial influence in their studies. Also, since most studies do not use the same set of family variables, their results often do not yield consistent results. In the following sections, studies that have included one or more of the familial variables indicated above have been included in the discussion.

#### **3.4.2.1 THE HOME (FAMILY) ENVIRONMENT**

Researchers (Tamir 1989:30; Welch, Anderson & Harris 1982:50) have shown that the relationship between the home and science achievement is depended on specific subjects. Areas such as reading are more related to the home environment whereas others such as science are more related to schooling. In this regard, Tamir (1989:33) reports that not a single home variable (parents' country of birth, parents' occupation, parents' education, family size, number of books at home) accounts for more than five percent of the variance in science achievement. A limitation of Tamir's study, however, is that it failed to include other important aspects of the family environment such as parenting styles, family interactions, perceptions children have concerning family support, and the like.

In other studies, however, Tamir (1987:92; 1991:27) found that home background exerts a significant but small influence on science achievement and that a science oriented home background affects positively functional knowledge and understanding in science courses. Fraser et al. (1987:170), in their meta-analysis study, referenced studies which found that measures of home and family conditions are related to science achievement. Ma and Kishor (1997:99) reported that students' perception of family support is related to achievement in mathematics. Perception of family support was defined as students' perceptions of parental attitudes and behaviours towards mathematics, including parents' assistance, expectation, and encouragement in their children's mathematics learning.

Similarly, Simpson and Oliver (1990:6) found that family support of science and attitude towards science of same sex parent accounted for thirty nine percent (39%) of the total variance in students' attitudes toward science. Simpson and Troots (1982:765) found that home commitment correlated strongly with students' science affective measures.

### 3.4.2.2 PARENTAL SOCIOECONOMIC STATUS

Several studies have repeatedly shown that parental socioeconomic status, as an aspect of the child's family background, is related to scholastic achievement (Mau 1997:272; Castejon & Vera-Munoz 1996:22; de Jong 1993:203; Anderson 1987:52; Gordon 1986:72-73). Hobbs (Caldwell & Ginther 1996:141) asserts that socioeconomic status is the single best predictor of academic achievement, with low socioeconomic status predicting low achievement. According to Brantlinger (1990:305), low-income students, compared to more affluent peers, have less positive school experiences and outcomes including intelligence and achievement test scores, grade point averages, class rank, and educational attainment. Also, students from a low socioeconomic background constitute the largest population of individuals considered to be at-risk of not graduating from high school (Caldwell & Ginther 1996:141). Banu (1986:197), on the other hand, found that parental literacy background exerts no effect on their children's academic achievement. In the Nigerian sample that Banu used, the literacy status of the family is related to the socioeconomic status of the family.

A similar pattern is found in the relationship between socioeconomic status and science achievement. From a synthesis of thirteen studies, Kremer and Walberg (1981:17-18) reported a positive relationship between parental socioeconomic status and science learning. Specifically, students from higher socioeconomic status homes scored higher on achievement measures of logical operations, science attitudes and interests, general cognitive learning in science, critical thinking and factual learning. In a meta-analysis carried out by Fleming and Malone (1983:486), socioeconomic status was found to have a mean positive correlation of 0,25 with measures of science achievement. This correlation, however, is forty percent smaller than the correlation of ability for the same performance measures. Crane (1996:309) also reported a low correlation between socioeconomic status and achievement in mathematics (a science related subject). The low correlation further decreased substantially when variables such as home environment were controlled.

Not only is there a difference in the achievement of high and low socioeconomic status students in science courses, but science itself is perceived by many researchers as occupying a higher status in comparison to other fields of study. Tamir (1989:32-33), for example, pointed out that if one accepts the commonly held position regarding indicators of socioeconomic and socio-cultural status, then it could be argued that non-science majors tend to occupy the lowest, whereas physics and chemistry majors occupy, on average, the highest socioeconomic status. Clark (1986:207) found that university students



who majored in natural sciences (mathematics, physics, chemistry and biology) were of a higher social class than students who majored in other subjects. "Paradigmatic science is an institutionalized, elite activity. It has a complex symbol system, extended training and induction periods, learned societies and a multitude of technical journals. It . . . has been controlled by white, middle-class Anglo-Saxon men" (Jeans 1994:91). As pointed out in chapter two, the participation rate of blacks in the sciences is low in comparison to the participation rate of whites. Such a situation is not healthy since it has a potential of reinforcing stereotypes that many educators are eagerly trying to correct. The situation also has implications for black children's motivation and self-concept towards science and science careers.

Other researchers, however, argue that it is actually what goes on in the family (that is, the family climate) that predicts students' achievement and not the child's socioeconomic status *per se* (Ma & Kishor 1997:92; de Jong 1993:203-4). Variables like parenting styles, parental support and encouragement for their child's schooling, intellectual stimulation, *et cetera*, play a major role in the achievement of all pupils, low socioeconomic status students included. In a study investigating differences in learning styles of low socioeconomic status for low and high achievers, Caldwell and Ginther (1996:144-145) found that the two groups of students (low socioeconomic status low and high achievers) differed only on variables associated with internal factors (that is, intrinsic motivation). Based on the results of their study, they put forward the hypothesis that "low socioeconomic background and low motivation interact in such a way that each compounds the effects of the other".

### 3.4.2.3 PARENTING STYLES

Another family variable that is an important factor in the achievement of science students is parenting style. Hein and Lewko (1994:274) reported that there is a positive relationship between authoritative parenting and academic achievement in science. Authoritative parenting is "characterised by parental responsiveness, encouragement, and open communication in addition to the establishment and firm enforcement of rules and standards" (Hein & Lewko 1994:263). These authors found that family-related measures that were specifically related to science and mathematics achievement were parental encouragement to pursue a career in the sciences, parental encouragement to excel in science and mathematics, "science sexism" in parental views, and perceived parental expertise in science and mathematics. Family structures, family values, and the cultural and physical settings of home life are thus important determinants of science achievement (Lees 1994:70).

### 3.4.2.4 PARENTAL BELIEFS

According to Jacobs (1991:518) there is a growing body of literature establishing the importance of parents' beliefs in influencing their children's achievement attitudes and academic performance. Jacobs referenced studies that demonstrated that parents' beliefs and expectations are related to the child's

self-perception of ability and achievement expectations. These studies further pointed out that parents' beliefs about children's abilities has an even greater influence on children's achievement attitudes than does previous performance. Similarly, Mau (1997:267) cites a number of studies that suggested that cultural upbringing is a strong factor contributing to the educational success of Asian students. According to Mau, Asian culture believes that a deficiency can be overcome with diligence. As such the value of hard work is prevalent in Asian families. Mau's study also demonstrated that Asian students spend a lot of time on homework and academic related activities. Finally, Asian students perceived significantly higher parental educational expectations.

What these studies imply is that parents who do not value education (for whatever reason) and who have no expectations on their children's scholastic achievements disadvantage the child. The child is robbed of a stimulating environment that is necessary for academic achievement.

#### **3.4.2.5 SUMMARY**

The family has been shown to influence science outcomes significantly. In particular, variables that constitute the family climate (interactions, discipline, perceptions) appears to influence students' science outcomes enormously. The magnitude of these variables is demonstrated by their moderating effect on parental socioeconomic status. In other words, family climate variables are able to compensate for the detrimental effects of low parental socioeconomic status.

In addition, it should be noted, for example, that the family-achievement relationship is not "acting" independently of other determinants of science achievement. Intuitively, it cannot be expected that all children from well structured families should achieve highly in science. In this regard Simpson and Oliver (1990:13) found in their ten year longitudinal study that the effect of family variables on science achievement is mediated heavily by self-related variables and that the latter are the major filters through which the relationship is formulated. School-related variables, in conjunction with family-related variables, also play a role in facilitating science achievement and in the next section a report of the role of the school in science achievement is provided.

### **3.4.3 THE SCHOOL**

#### **3.4.3.1 THE SCHOOL AND SCIENCE ACHIEVEMENT**

Children spend a lot of time at school and as such a relationship between school-related variables and scholastic achievement could be expected. In a study comparing educational inequality and academic achievement in England and France, Lees (1994:68) reported that the design of the education system and the particular institutions within them determines, to a great extent, the educational achievement of

students. In chapter two of this study, it was shown that the South African education system has a history which made a minority of schools exceptional in academic achievement whereas others, the majority, to have mediocre achievements. Black schools have had a relatively lower achievement history when compared to white schools. Black science students, in particular, have been shown to achieve lower than their white counterparts. In metropolitan areas, this state of affairs has resulted in large numbers of black children seeking accommodation at traditionally white schools. The perception (and in most cases the outcome) being that attending a white school will result in better achievement. In this sense, schools do make a difference as far as the academic achievement of children is concerned.

Although research on school determinants is a relatively recent field as far as academic achievement is concerned (Castejon & Vera-Munoz 1996:22), several studies have been conducted in this regard. In the literature, a distinction is made between school environment (climate) and classroom environment (climate). School environment is seen as the sum of the classroom environments within the school (Fraser 1986:9) or the socio-psychological environment of the school (Fraser et al. 1987:171). Biniaminov and Glasman (1983:251), in their literature review, reported that agreement has been only moderate that school variables do influence achievement. Also, few studies were found that incorporate school variables in conceptual (theoretical) models. The low number of research studies using the school as a unit of analysis, particularly at the secondary school level, could be attributed to complexities such as the large number of teaching staff, teachers' departmentalized schedules, staff decision-making, *et cetera*.

In a large scale study of grade eight students in American schools (N = 18719), Lee and Burkam (1996:638) reported that the school's socioeconomic status has a powerful effect on achievement in physical science. Other variables that they found to show some influence on science achievement were type of school (Catholic/Public), rural or suburban schools and geographical area of the school (South/West/Northeast). Fraser et al. (1987:170-175), on the other hand, found no clear-cut relationship between school climate and student achievement in science whereas Simpson and Oliver (1990:7) found a somewhat low relationship. Quantitatively, a combination of five school-related variables (number of hours devoted to science homework, obtaining high grades in science and mathematics, liking for science and mathematics) were found to account for only five percent of the variance in science achievement.

Staver and Walberg (1986:99) pointed out that it is not helpful to use the school as a unit of analysis since important variables developed through individuals' interactions and learning experiences in classes, instructional methods, and curricula could remain hidden. Their suggestion is that data must be analysed at the student level. In this vein they reported that "major differences in student achievement between private and public schools appear attributable to relatively fixed characteristics of students and

to their experiences beyond the school environment rather than to factors easily alterable by educators" (page 110).

Classroom environment, on the other hand, is defined by Myers and Fouts (1992:930) as a unique interactive combination of teacher behaviour, curriculum expectations, and pupil-to-pupil interactions. Fraser et al. (1987:177) views classroom environment as the socio-psychological environment in the classroom as perceived by the students. Unlike school environment, classroom environment has been shown to be positively related to science achievement (Fraser 1989:315; Fraser & Fisher 1982:514). Furthermore, students' cognitive outcomes can be improved by changing classroom environments in desired directions (Burden & Fraser 1993:239; Fraser, Malone & Neale 1989:196-199).

Haukoos and Penick (1987:739) studied the effect of interactions in the classroom on science achievement. Students were exposed to two different classroom climates. Discovery classroom climate students were encouraged in the laboratory to manipulate and explain (in whatever way they wished) both their actions on the materials and the results of these actions. Similarly, content was presented and discussed in a manner that elicited student ideas which were neither judged right nor wrong. Non-discovery classroom climate students were told what to do in the laboratory and how to do it, much as they were in content presentation, and results being praised or rejected depending on how well they matched with original directions. Such diverse classrooms did influence student achievement. A major advantage of the discovery classroom climate is its high level of students' individual control. In this regard, classrooms which allow for and encourage personal control were found to be more effective (Caldwell & Ginther 1996:145) than competitive and teacher centred classrooms. Flink, Boggiano and Barrett (1990:921) found that students who had more controlling teachers performed lower than students of less controlling teachers. Increasing students' Interactions in the classroom (for example, by allowing students to participate in setting goals for their own learning, employing cooperative group learning, and the like) therefore interacts directly and indirectly with students' academic achievement.

Intuitively, teacher characteristics (level of education, personality, attitudes, *et cetera*) could be expected to be positively related to students' scholastic achievements. Unqualified and under qualified teachers, teachers who are not committed to teach, rote teaching, and the like, are some of the problems attributed to high failure rates in black schools (see chapter two). Few studies, however, actually investigated such assertions empirically. From their meta-analysis of nineteen ( $n = 19$ ) studies, Sweitzer and Anderson (1983:456) found an effect size of 0,44 between initial training of teachers and subsequent student achievement, suggesting that initial teacher training does have an impact on students' achievement. A study by Druva and Anderson (1983:475) reported a low correlation among measures of teacher characteristics and student outcomes. Of the reported teacher characteristics (age, sex, amount of science study, experience, personality, attitudes), the teacher's training in the content of science has the

highest correlation with student achievement ( $r = 0,19$ ) and accounts for four percent of the variation in student achievement.

### 3.4.3.2 THE SCHOOL AND ATTITUDE TOWARDS SCIENCE

In section 3.4.3.1, it was argued that the effect of the school on students' science achievement is more than that of the home. It could be expected then, that students' attitudes toward science should be greatly influenced by school variables. Several studies confirm this assertion. In a study correlating a number of self, school and family variables with attitude towards science, Simpson and Oliver (1990:5) found that the school variables were the most strongly related to attitude towards science. The curriculum, class climate, friends, best friend, teacher and physical environment accounted for seventy three percent (73%) of the variance in attitude towards science. Mordi (1991:48), using a sample of Nigerian primary school children, found that a large proportion of the variance in students' attitudes toward science were accounted for by the teaching and learning variables (41%), students' variables (16%), and the school (11%). Home variables (1%) turned out not to be good predictors of students' attitudes toward science.

The strong effect of the school on attitude towards science is further demonstrated by the variation in attitudes caused by different schools and different school types. For example, tests carried out by Banu (1986:198) to measure the effects of school types on attitudes of students toward science indicated that (1) the individual schools have different effects on students' attitudes toward science; (2) students in the special science schools have more positive attitudes toward science than students from other schools; and (3) female students in single-sex schools show more positive attitudes toward science than female students in the mixed schools. Using data from a large scaled study called the High School and Beyond project, Coleman and associates (1981), cited by Oliver and Simpson (1988:145), found that different types of high schools and the age of the students were significant sources of variation with respect to the attitudes of students.

What goes on in the classroom (curriculum materials, instructional methods, interactions in the class) influence students' perceptions of the science classroom. The latter has been shown to correlate positively with achievement and attitude (Fraser & Fisher 1982:514). Du Toit et al. (1991:52) found that grade eleven students expressed relatively low interest in and poor attitude towards science when compared to grade ten students. In their explanation, the authors argue that this finding is possibly due to the negative effects of a highly theoretical and abstract syllabus content at grade eleven. Demonstrations that have a visual impact, however, could be used to cause a change in the attitudes of students. Hamrick and Harty (1987:22) investigated the effect of resequencing general science content (that is, content arranged into an interrelated pattern) on the attitudes toward science of grade six students. They found that students who had experienced resequenced content exhibited significantly

more positive attitudes toward science than the control group (that is, students whose content had not been resequenced).

In a study investigating science classroom environments, Myers and Fouts (1992:936) reported that:

- (1) "Positive attitudes toward science were found in classrooms which had high levels of involvement, high student-to-student affiliation, high teacher support, high order and organization, high teacher use of innovative teaching strategies, and low levels of teacher control."
- (2) Academic preparation in the specific field of science also influence classroom environment and students' attitudes toward science. Students of teachers who were academically trained in that specific subject were found to have more positive attitudes toward science.

Based on this and other findings, Myers and Fouts argue that teachers may improve their students' attitudes toward science by:

- (a) providing more hands-on activities;
- (b) providing more student-relevant topics that encourage student involvement;
- (c) using more cooperative learning activities to promote student-to-student interaction;
- (d) focussing on positive and supportive communication with every student;
- (e) providing an organized classroom setting; and
- (f) diversifying their teaching strategies.

#### **3.4.3.3 SUMMARY**

Three of the school related variables were found to significantly influence students' achievements in science positively. The variables are the socioeconomic status of the school, the classroom environment, and the initial training of teachers.

Also, school variables have been shown to influence students' attitudes toward science. The effect of school variables and self variables on students' attitudes toward science are more stronger than the effects of the home. In particular, school variables that have been shown to have an effect on students'

attitudes toward science could be grouped and classified as school type, classroom environment, curriculum materials, and teachers' academic preparedness.

### 3.5 CONCLUSION

The literature review undertaken in this study revealed several important determinants of students' science outcomes. These determinants were classified, for study purposes, into psychological factors and social factors.

Of the psychological factors investigated, the student's ability accounted for much of the variance in students' science achievement measures. This finding has several educational implications, particularly for black South African students. First, the implication is that poor achievement in physical science courses at an earlier level usually results in a chain-reaction of failure in subsequent physical science courses. Second, the resulting failures produce feelings of scholastic inadequacy in the students, thus hampering the development of a positive physical science self-concept. The latter has been shown to correlate significantly with science outcomes. Third, students with negative science self-concepts are usually not motivated to study science after the compulsory level, choosing instead to study perceived easier options, namely humanities. Finally, only a handful of students become scientifically literate and as such the country suffers tremendously in terms of economic development. One manifestation of which is the prevailing high crime rate.

A second psychological factor that was particularly relevant for the South African context is the child's race. The effects of race, for example, were shown to be higher than that of parental socioeconomic status and gender. Also, black students were shown to be achieving at lower levels than their white counterparts although their attitudes were not much different. The implication is that positive attitudes are not capable, on their own, to overcome the negative effects of variables such as educational neglect, lack of resources, and the like of which black children are experiencing. The finding that blacks are achieving far lower than whites further shows the importance of the present study. That is, to focus on factors influencing such low achievements of urban black students.

Due to the many problematic issues in black education, children's educational experiences are at most very negative. As such they possibly have negative academic self-concepts and low motivation. The effect is that they usually do not aspire for scientific careers since the latter requires knowledge of physical science, a subject considered very difficult. A major challenge in black education is thus to find mechanisms for enhancing children's affective lives at school since the latter accounts for a substantial amount of the variance in science achievement.

To enhance children's affective lives, conditions in the family and school must be conducive. The literature reviewed in this study has shown that what goes on in the family and schools influence children's science achievement and attitudes. In both social structures (the family and school), an atmosphere of mutual acceptance, love, and trust produces great results. Parents and teachers who are not domineering, who gives enough room for children's emancipation, and who cares for children and support them in their academic activities have been shown to enhance children's science outcomes.

The factors identified in this study, however, do not merely exert individual effects on science outcomes but act together to produce a compounded effect. For example, although low parental socioeconomic status is associated with low science achievement, students who are highly motivated and who are adequately stimulated in the family and the school may achieve highly in physical science. In this chapter, the emphasis was not much on the temporal and joint effects of the identified psychological and social factors but on their individual effects. The temporal and joint effects of the identified psychological and social factors are explored in the next chapter.



## CHAPTER 4

### THE METHODOLOGICAL APPROACH TO THE STUDY OF SCIENCE ACHIEVEMENT AND ATTITUDE

#### 4.1 INTRODUCTION

In the previous chapter, research studies that investigated determinants of science achievement and attitude were reported. The researchers in these investigations employed correlation studies, factor analyses, regression studies, and the like in their endeavour to interpret their results. Based on the results of such research efforts, a substantial amount of knowledge exist as to the determinants of science outcomes. This chapter, however, presents the results of investigations using the methodological approach.

Several names were found in the literature referring to the methodological approach, namely structural modelling, linear structural equation modelling, path analysis, analysis of covariance structures, analysis of moment structures, and causal modelling. According to Joreskog and Sorbom (1989:1), structural equation models (SEMs) have been applied successfully in many disciplines, including education. The method has been used successfully as far as scholastic achievement is concerned. Since this study investigates some aspects of scholastic achievement, structural equation models are employed to direct the research.

This chapter begins with background information regarding the rationale why most investigators make use of structural equation modelling in studying the determinants of science outcomes. In other words, the usefulness of thinking in terms of models is highlighted. Next, a brief introduction to the processes involved and the terminology used in the methodological approach (structural modelling) is presented. To reiterate, only an introduction is given since a complete discussion of this topic is beyond the scope of this work.

After the introduction, a synthesis of studies which employed the methodological approach in their investigations are presented. In the review, emphasis is placed on possible weaknesses of the design of the proposed models and on the results of research reported in chapter three. As such, a theoretically justified model is presented at the end of the chapter.

## 4.2 THINKING IN TERMS OF MODELS

This study purports to study the influence of psychological and social factors on science achievement and attitude by making use of a theoretically constructed model. Models have been used successfully in econometrics, sociometrics, psychometrics and other social sciences. Thinking in terms of models is useful and its merit is demonstrated by the following example (see Asher 1983:8-9).

Consider the case of a decision maker whose goal is to improve student performance on various standardized tests. Assume that the decision maker has one basic variable over which he or she has control: the amount of money to be spent on education. Such a variable might be labelled "manipulable" since its level can be varied by the conscious decision of actors within certain limits imposed by various external constraints. But rather than simply hypothesising that increased expenditures for education will improve student performance, one might ask the more relevant question: How is it that increased expenditures for education might translate into better student performance? That is, what are the ways in which increased expenditures actually produce improved student performance?

The decision maker might well recognize that options are available as how additional moneys might best be allocated to improve student performance. For example, should money be channelled into hiring more teachers so as to lower the pupil/teacher ratio, into attracting better teachers, or into improving facilities and developing (or expanding) innovative programmes? What might be the optimal mix of funding for these options? We might represent the decision maker's situation at this stage by the diagram in Figure 4.1.

**Figure 4.1 A simple arrow diagram indicating how education expenditure might affect student performance**

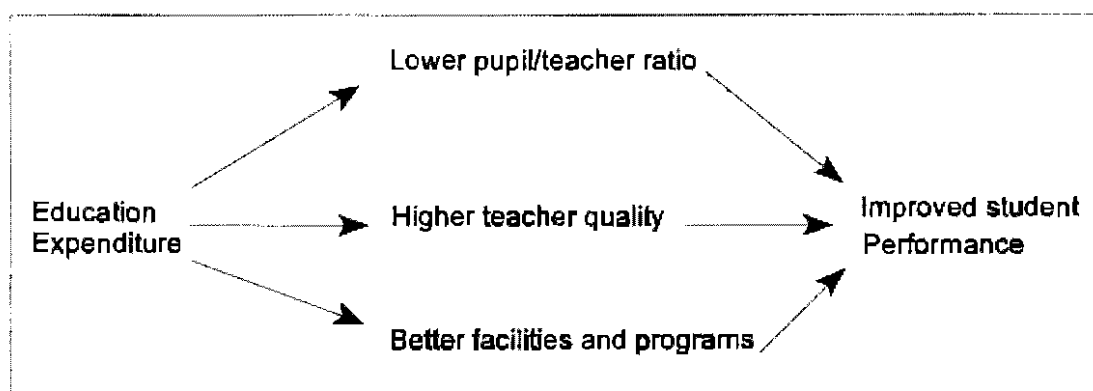

But there are additional variables that affect student performance that are not as directly under the control of the decision maker. These might include the supportiveness of the family environment toward educational achievement, the student's abilities, and the student's feelings toward the educational system. In addition, there might be interrelationships among the manipulable and non-manipulable variables. For example, perhaps more and better teachers, facilities, and programmes will influence the student's view of education. Hence, we might come up with the more complete model illustrated in Figure 4.2.

**Figure 4.2** A more complex arrow diagram indicating how education expenditures and family environment might affect student performance.

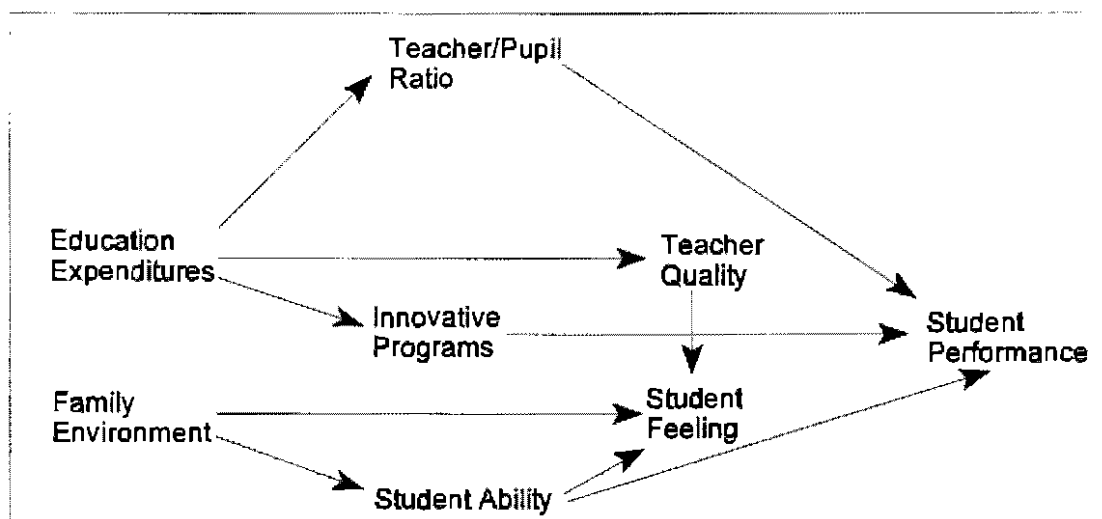

Note how the model not only specifies the relationships between the independent variables and the ultimate dependent variable of interest (student performance), but also makes explicit the relationships among the prior variables. Each included linkage implicitly represents a hypothesis that would be tested by estimating the magnitude of the relationship. While actual estimation of the linkages may or may not be possible, depending on whether satisfactory indicators can be constructed, appropriate data

collected, and the like, the point to be made here is that the kind of thinking illustrated by the example has greater promise of increasing our understanding of social and political phenomena than simply correlating variables in a relatively unthinking manner.

### 4.3 STRUCTURAL EQUATION MODELLING

Structural equation models, avers Joreskog and Sorbom (1989:1), have proven useful in solving many substantive research problems in the social and behavioural sciences. Also, because of their explanatory ability, structural equation models are nowadays the most used methods in research on the determinants of academic achievement (Adanez 1989; Marsh 1990; Caldas 1992; Castejon & Vera-Munoz 1996; Marsh & Yeung 1997) and science outcomes (Schibeci & Riley 1986; Schibeci 1989; Rennie & Punch 1991; Reynolds & Walberg 1991, 1992; Germann 1994; Lawrenz & Huffman 1996).

A detailed description of the conduct and historical development of structural equation modelling is beyond the scope of this thesis and is available elsewhere (Cuttance & Ecob 1987; Bollen 1989; Joreskog & Sorbom 1989; Pedhazur & Schmelkin 1991). In the following sections, only a brief description is provided of the main features of structural equation models.

#### 4.3.1 CAUSALITY

A structural equation model (SEM) is used to specify the phenomena under study in terms of putative cause-and-effect variables and their indicators (Joreskog & Sorbom 1989:1). In other words each equation in the model represents a causal link rather than a mere empirical association.

There has been heated debates in the literature surrounding "causality" in the social and behavioural sciences (Cliff 1983; Saris & Stronkhorst 1984; Freedman 1987; Pedhazur & Schmelkin 1991; and many others cited in these studies). As an example, philosophers contend that there is no way it can be proved that one phenomenon is the actual cause of another. As such causal theories can never be verified and therefore the causal approach should be abandoned. Saris and Stronkhorst (1984:2), on the other hand, argues that the situation with respect to causal theories is not different from the one encountered for any other kind of theory, namely that it is never possible to prove that a theory is correct, since there are always many different theories which can describe the same observations. The question that should be raised, however, is whether or not theories - including causal theories - can be rejected on the basis of observations? Inherent in the structural equation modelling process is the testing of the theoretically constructed models based on empirical observations.

Besides the philosophical debate around the concept "causality", there have been other debates concerning the methodology used in causal analyses, the appropriateness of statistical tools used, the

preciseness of measurements, and the like. For a discussion of these and related issues, the references provided above can be consulted.

#### **4.3.2 ANALYSIS OF NON-EXPERIMENTAL DATA**

In the natural sciences, analysis of variance is used to test hypotheses with respect to the causal effects of variables on each other (Saris & Stronkhorst 1984:v). Causality can thus be proved since rigorous experimentation under controlled conditions can be implemented. In non-experimental research, however, such controlled conditions do not exist. Causal inference is thus based on studies in which causal models and hypotheses are statistically evaluated. According to Joreskog and Sorbom (1989:1), causal relationships cannot be proved, they can only be established as more or less reasonable relative to alternative specifications.

As said earlier, the investigator in non-experimental research does not manipulate the variables in the study. According to Saris and Stronkhorst (1984:3), this has two consequences. First, it implies that one does not obtain evidence concerning the causal ordering of events. This is particularly true in investigations that utilize cross-sectional data. In such cases, the causal ordering of events should be settled in a different way and requires extra theoretical work since a sequence of events cannot be derived from the data. However, a theory may be posited in which a particular causal ordering exist and then such a theory can be tested with non-experimental data. Investigations that make use of longitudinal data, however, do not have the same difficulties in causal ordering as in studies using cross-sectional data.

A second consequence is that the subjects which are studied in non-experimental research may be different with respect to many characteristics, and not only in the isolated aspect for which an effect is sought. As such it is often not clear if a relationship found between the causal variable and the effect variable should be attributed to a causal effect or to the effect of other variables (partly or entirely). Such measurement related problems are discussed in the next section (4.3.3). In the meantime, it suffices to point out that social scientists circumvent the above mentioned problem by making use of "measurement models". Measurement models are constructed such that the problems raised above can be addressed.

#### **4.3.3 THE MEASUREMENT MODEL**

During model formulation (or formulation of theories) in the social and behavioural sciences, theoretical concepts or constructs which are not directly measurable or observable are often derived. Such unobservable constructs are called latent variables. According to Joreskog and Sorbom (1989:2), social scientists have to use latent variables since many of the concepts and constructs that they want to work with are not directly measurable, for example people's behaviour, attitudes, feelings and motivations.

Although latent variables cannot be measured directly, a number of indicator variables can be used to measure various aspects of these latent variables reasonably accurately. Each observable indicator has a relationship with the latent variable and in order to measure each latent variable correctly, a number of indicator variables are needed. In other words a single indicator variable often produces poor measurement of the latent variable (Pedhazur & Schmelkin 1991:58).

Another reason for using latent variables in the social sciences is that most measurements contain sizeable errors (observational errors). Errors of measurement arise because of imperfection in the various measurement instruments (questionnaires, tests, *etcetera*) that are used to measure such abstractions as people's behaviour, attitudes, feelings and motivations. Even if valid measurements of these variables could be constructed, it is usually impossible to obtain perfectly reliable variables.

The measurement of constructs or concepts in the social sciences is therefore a major problem. In order to minimize errors in the social scientific investigation, a measurement model is imperative.

The purpose of a measurement model is to describe how well the observed indicators serve as a measurement instrument for the construct or latent variables. The key concepts here are that of measurement and of reliability and validity. Measurement models often suggest ways in which the observed measurements can be improved (Joreskog & Sorbom 1989:76).

In the formulation of a measurement model, a disturbance term is usually incorporated. The disturbance term may represent the following (Saris & Stronkhorst 1984:33-34):

- (1) The effect of unknown variables. It often happens in the social sciences that the right questions have not been asked and as such the right variables have not been identified.
- (2) The effect of known but omitted variables. It sometimes happen in the social sciences that the number of, say, indicator variables for a particular latent variable are overwhelming. To maintain parsimony the scientist may therefore ignore less important variables. The effect of such a move is that an uncertainty in the relationship is generated.
- (3) The randomness of human behaviour. This is due to the element of unpredictability in human behaviour.
- (4) Measurement error. The care, precision and perfection used in measuring natural science variables is often not possible in the social sciences.

The presence of a disturbance term in the social science relationships imply that inferences cannot be deterministic. As such all the equations in the structural equation models are usually stochastic (Saris & Stronkhorst 1984:34). This reiterates the previously mentioned assertion of Joreskog and Sorbom that causal relationships cannot be proved. Instead, they can only be established as more or less reasonable

relative to alternative specifications. For illustrative purposes, a path diagram (causal diagram) of a measurement model is shown in figure 4.3.

**Figure 4.3 The Congeneric Measurement Model (after Joreskog & Sorbom 1989:77)**

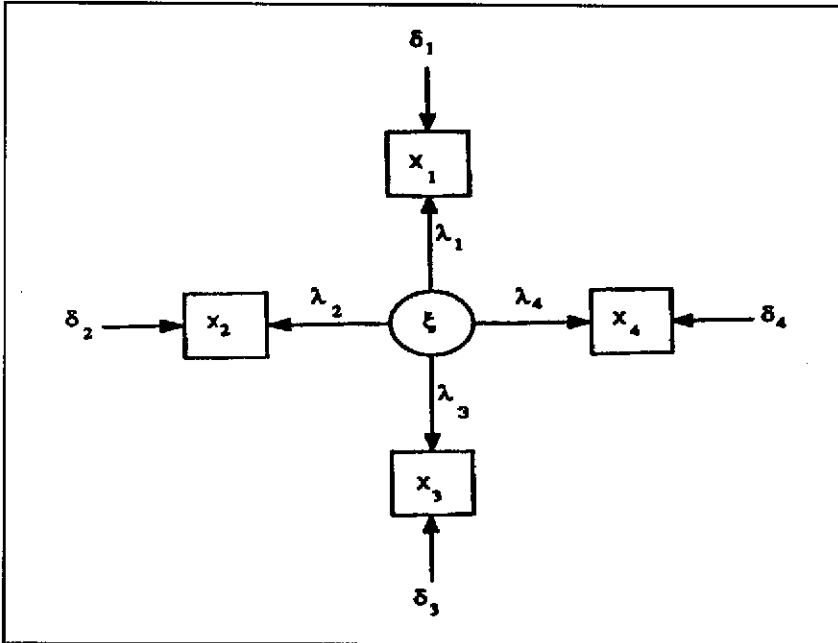

where

$x_1, x_2, x_3, x_4$  represent observed variables,

$\xi$  represent a latent variable,

$\delta_n$  ( $n=1,2,3,4$ ) represent the measurement errors in  $x_n$  ( $n=1,2,3,4$ ),

$\lambda_n$  represent the regression coefficients in the relationships between each of the observed measures  $x_n$  and  $\xi$ .

Arrows In this case the arrows do not represent direct causal influences in the usual sense, but portray the fact that if the latent variable were observed it would produce values of the observed variables  $X_n$ .

From figure 4.3, the four paths (arrows) can be represented by four equations:

$$x_1 = \lambda_1 \xi + \delta_1$$

$$x_2 = \lambda_2 \xi + \delta_2$$

$$x_3 = \lambda_3\xi + \delta_3$$

$$x_4 = \lambda_4\xi + \delta_4$$

This transition from path diagrams to equations is further explored in the next section (4.3.4).

#### 4.3.4 THE STRUCTURAL EQUATION MODEL

In the previous section (4.3.3) it was shown that the measurement model specifies how the latent variables or hypothetical constructs are measured in terms of the observed variables. The measurement model was also shown to describe the measurement properties (validities and reliabilities) of the observed variables.

The Structural Equation Model (SEM), on the other hand, originated from the merging of two approaches: multiple regression and factor analysis (Ecob & Cuttance 1987:9). The multiple regression approach expresses the relationship of a dependent variable to a number of regressor variables, the partial relationship with each variable being expressed by the regression coefficient corresponding to that variable. In contrast, the factor analysis approach finds a number of underlying or latent variables (factors) that account for the common relationship among a number of observed variables. Within the structural equation framework, the regression model is specified in the *structural model* and the factor analysis model is specified in the *measurement model*.

The SEM, however, is more than just the sum of the regression and factor analysis models. According to Goldberger (1973:2-6), a distinction can be made between the SEM and the regression model. Each equation in a structural equation model represents a causal link rather than a mere empirical association whereas each equation in a regression model represents the conditional mean of a dependent variable as a function of explanatory variables. This distinction renders conventional regression analysis an inadequate tool for estimating structural equation models. Specifically, there are three situations in which regression parameters fail to estimate the parameters of structural equation models:

- (1) When the observed variables contain measurement errors and the interesting relationship is among the true or disattenuated variables.
- (2) When there is interdependence or simultaneous causation among the observed response variables.
- (3) When important explanatory variables have not been observed (omitted variables).

The use of structural equation models therefore requires statistical tools that are based upon, but go well beyond, conventional regression analysis and analysis of variance (Joreskog & Sorbom 1989:1). Since 1973, however, computer programs were developed that not only provide efficient estimation procedures



for the causal effect but also test causal theories. Two such computer programs commonly used in the literature are the LISREL (Joreskog & Sorbom 1989) and the EQS (pronounced "x")(Bentler 1989) software packages.

"The structural equation model specifies the causal relationships among the latent variables and describes the causal effects and the amount of unexplained variance" (Joreskog & Sorbom 1989:2). Since most theories in the social sciences have more than one effect variable, there may be various causal links between the variables in the theory. Also, because each causal link can be represented with an equation, most social science models have several equations which are connected in a system (Saris & Stronkhorst 1984:62).

As one can easily get confused by the numerous equations in a structural equation model, it is often useful to draw a path diagram. When properly drawn, a path diagram not only communicates the basic conceptual ideas of the model but can represent the corresponding algebraic equations of the model and the assumptions about the error terms in these equations (Joreskog & Sorbom 1989:5). For illustrative purposes, a path diagram of a hypothetical model is shown in figure 4.4.

According to Joreskog and Sorbom (1989:5), the following conventions for path diagrams are assumed.

- (i) Observed variables such as  $x$ - and  $y$ -variables are enclosed in squares or rectangles. Latent variables such as  $\xi$ - and  $\eta$ -variables are enclosed in circles or ellipses. Error variables such as  $\delta$ -,  $\epsilon$ - and  $\zeta$ -variables are included in the path diagram but are not enclosed.
- (ii) A one-way arrow between two variables indicate a postulated direct influence of one variable on another. A two-way arrow between two variables indicates that these variables may be correlated without any assumed direct relationship.
- (iii) There is a fundamental distinction between independent variables ( $\xi$ -variables) and dependent variables ( $\eta$ -variables). Variation and covariation in the dependent variables is to be accounted for or explained by the independent variables. In the path diagram this corresponds to the statements
  - no one-way arrows can point to a  $\xi$ -variable
  - all one-way arrows pointing to an  $\eta$ -variable come from  $\xi$ - and  $\eta$ -variables.
- (iv) Coefficients are associated to each arrow as follows:
  - An arrow from  $\xi_i$  to  $x_j$  is denoted  $\lambda_{xi}^{(x)}$
  - An arrow from  $\eta_j$  to  $y_a$  is denoted  $\lambda_{\eta j}^{(y)}$
  - An arrow from  $\eta_h$  to  $\eta_j$  is denoted  $\beta_{jh}$
  - An arrow from  $\xi_i$  to  $\eta_j$  is denoted  $\gamma_{ji}$
  - An arrow from  $\xi_i$  to  $\xi_i$  is denoted  $\phi_i$
  - An arrow from  $\zeta_h$  to  $\zeta_j$  is denoted  $\psi_{jh}$

- An arrow from  $\delta_b$  to  $\delta_a$  is denoted  $\theta_{ab}^{(\delta)}$
- An arrow from  $\epsilon_d$  to  $\epsilon_c$  is denoted  $\theta_{cd}^{(\epsilon)}$

The last four arrows are always two-way arrows. Each coefficient has two subscripts, the first being the subscript of the variable where the arrow is pointing to and the second being the subscript of the variable where the arrow is coming from. For example,  $\gamma_{23}$  corresponds to the arrow from  $\xi_3$  to  $\eta_2$ . For two-way arrows the two subscripts may be interchanged so that  $\phi_{21} = \phi_{12}$  in figure 4.4. Arrows which have no coefficient in the path diagram are assumed to have a coefficient of one.

Figure 4.4 A Path Diagram for a Hypothetical Model (After Joreskog & Sorbom 1989:7)

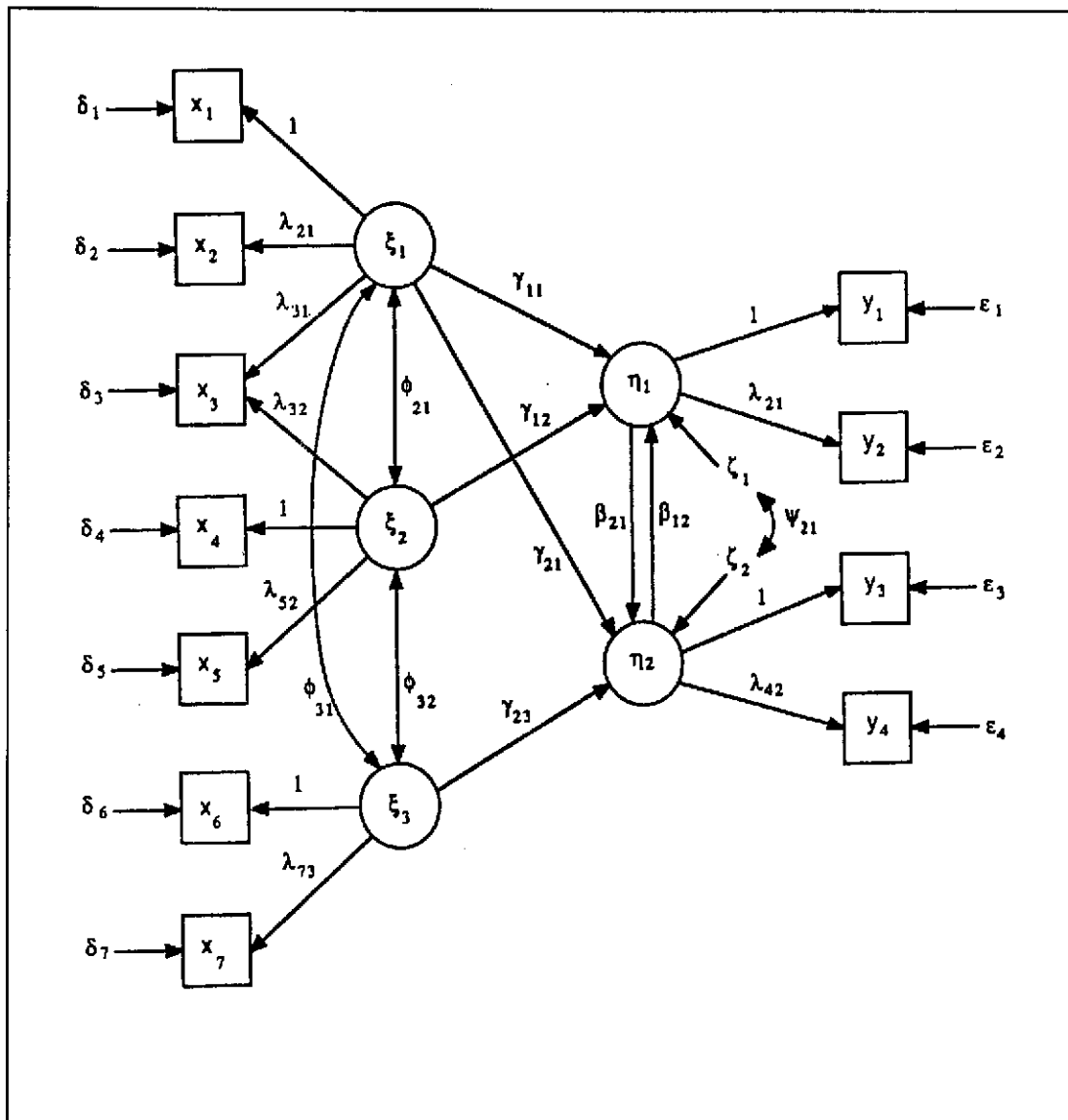

- (v) All direct influences of one variable on another must be included in the path diagram. Hence the non-existence of an arrow between two variables means that it is assumed that these two variables are not directly related. (They may still be indirectly related, however.)

If the above conventions for path diagrams are followed it is always possible to write the corresponding model equations by means of the following general rules:

- (vi) For each variable which has a one-way arrow pointing to it there will be one equation in which this variable is a left-hand variable.
- (vii) The right-hand side of each equation is the sum of a number of terms equal to the number of one-way arrows pointing to that variable and each term is the product of the coefficient associated with the arrow and the variable from which the arrow is coming.

Following the above rules, equations for the path diagram in figure 4.4 can be written. There are seven x-variables as indicators of three latent  $\xi$ -variables. Note that  $x_3$  is a complex variable measuring both  $\xi_1$  and  $\xi_2$ . There are two latent  $\eta$ -variables each with two y-indicators. The five latent variables are connected in a two-equation interdependent system. The model involves both errors in equations (the  $\zeta$ 's) and errors in variables (the  $\epsilon$ 's and  $\delta$ 's).

The *structural equations* are

$$\begin{aligned}\eta_1 &= \beta_{12}\eta_2 + \gamma_{11}\xi_1 + \gamma_{12}\xi_2 + \zeta_1 \\ \eta_2 &= \beta_{21}\eta_1 + \gamma_{21}\xi_1 + \gamma_{23}\xi_3 + \zeta_2\end{aligned}$$

The *measurement model equations* for y-variables are

$$\begin{aligned}y_1 &= \eta_1 + \epsilon_1 \\ y_2 &= \lambda_{21}\eta_1 + \epsilon_2 \\ y_3 &= \eta_2 + \epsilon_3 \\ y_4 &= \lambda_{42}\eta_2 + \epsilon_4\end{aligned}$$

and the *measurement model equations* for x-variables are

$$\begin{aligned}x_1 &= \xi_1 + \delta_1 \\ x_2 &= \lambda_{21}\xi_1 + \delta_2 \\ x_3 &= \lambda_{31}\xi_1 + \lambda_{32}\xi_2 + \delta_3 \\ x_4 &= \xi_2 + \delta_4 \\ x_5 &= \lambda_{52}\xi_2 + \delta_5 \\ x_6 &= \xi_3 + \delta_6 \\ x_7 &= \lambda_{73}\xi_3 + \delta_7\end{aligned}$$

In these equations, the second subscript on each coefficient is always equal to the subscript of the variable that follows the coefficient. This can serve as a check that everything is correct. The three sets of equations given above can also be written respectively in three matrix forms. As matrix algebra requires advanced mathematical knowledge, references to matrices will be avoided as far as possible.

Now that structural equation models have been briefly described, the theoretical model of this study can be constructed. First, however, is a review of studies that used structural equation models in their research designs and a summary of the major research findings using the theoretical approach.

#### 4.4 REVIEW OF CAUSAL MODELS IN SCIENCE ACHIEVEMENT AND ATTITUDE

One of the earliest models on science achievement and attitude was developed by Keeves (1974:20). In this causal model (figure 4.5), based on longitudinal data, children's final achievements in science were found to be caused by previous achievement in science, classroom structure, home attitudes, home processes and classroom interactions. Children's attitudes toward science were caused by peer group activities, previous attitudes, sex, classroom interactions and final achievement.

Figure 4.5 Path diagram for performance in science (after Keeves 1974:20)

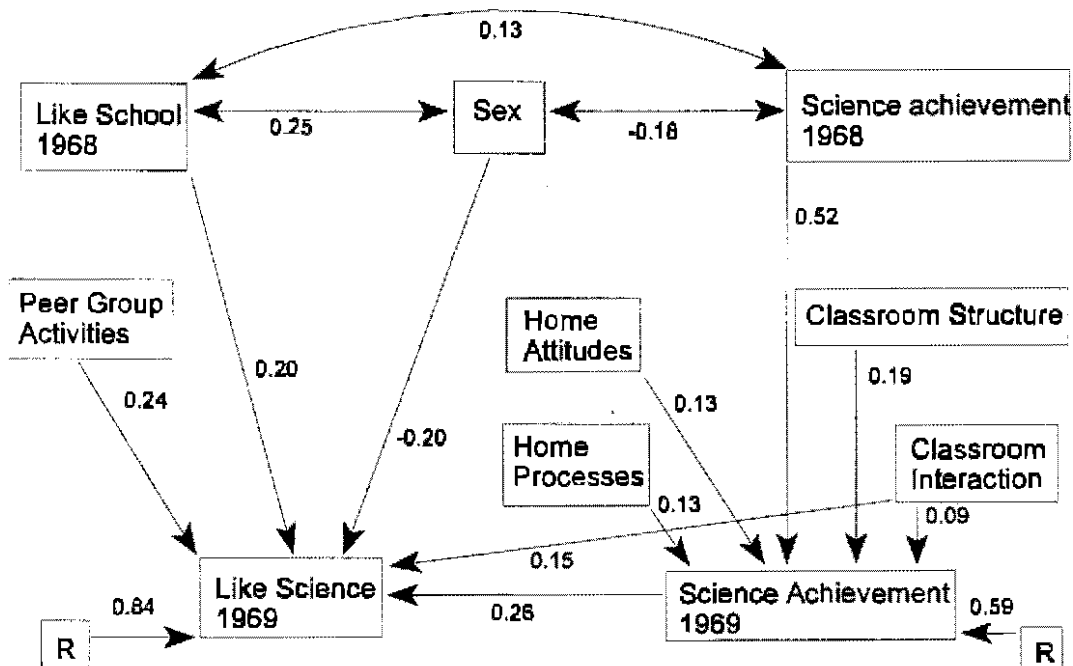

The latent variables classroom structure, home attitudes, home processes, classroom interactions, peer group activities and attitudes toward science were represented by the following indicator variables.

**Classroom structure:** teacher is a science specialist, number of science lectures attended by teacher, number of students in the class, number of periods per week in a laboratory, the average occupational status of the class.

**Home attitudes:** father's attitudes towards the child's present education, mother's attitudes towards the child's present education, father's ambitions for the child's future education and occupation, mother's ambitions for the child's future education and occupation, parents' hopes and aspirations for themselves.

**Home processes:** parents report of favourable relations between home and school, use of books and library facilities, provision of help with formal school work, arrangements made for tackling home assignments.

**Classroom interactions:** interaction between the teacher and the individual student and the number of praise statements entered in the student's workbook.

**Peer group activities:** participation in mathematics and science activities by the child's friends.

**Attitude towards science:** liking of school science.

Although this model identified three important determinants of science achievement (previous achievement, home variables and classroom variables), it failed to include the effects of affective variables (self-concept, motivation) in the causal model. The omission of these important variables are evident in the high amount of unexplained variance in science achievement. In addition, several design features were not adequately addressed by this model. For example, attitude towards science was measured by only one indicator variable - liking of science, hence increasing measurement error in the model.

Other studies (Biniaminov & Glasman 1983, Adanez 1989, Castejon & Vera-Munoz 1996), which were aimed at improving the amount of explainable variance, were subsequently undertaken. Of these studies, the study by Castejon and Vera-Munoz (see figure 4.6) explains a substantially high amount of variance in academic achievement (80%). The success of this study could be attributed, among others, to the inclusion of most important causes, the improved measurement of latent variables - each measured by several indicator variables, and the use of efficient computer programs in the analysis of data. Here also, the important determinants of academic achievement were found to be previous achievement, process variables of the school and personal variables (self-concept and motivation). The home variables had an indirect effect through previous achievement and personal variables. Individual variables (intellectual ability, previous achievement, self-concept, motivation) were found to be the main determinants of children's final achievement.

**Figure 4.6 The Structural Equation Model of Academic Achievement**  
(after Castejon & Vera-Munoz 1996:25)

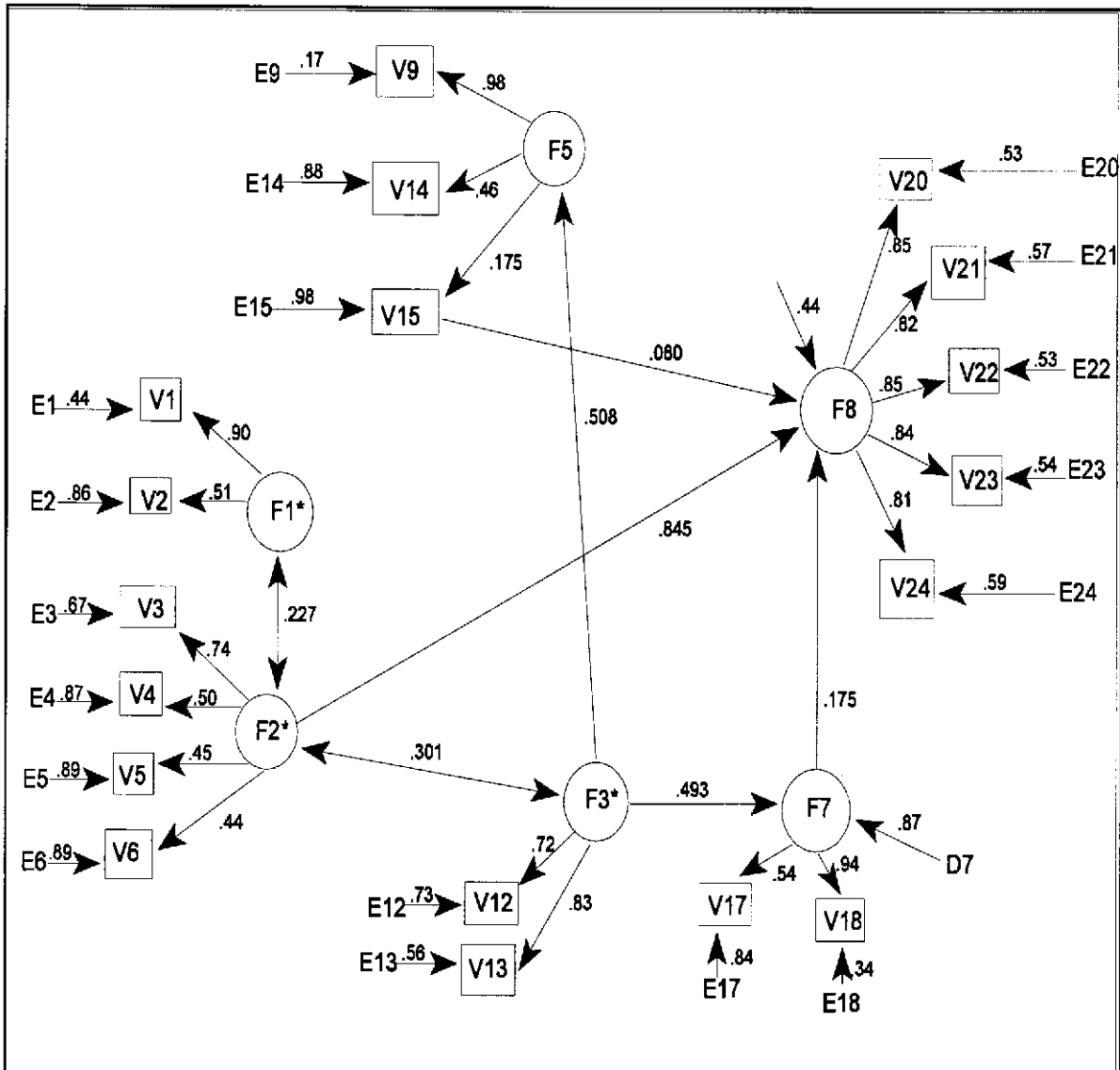

Observed variables: V1 = Parents' occupation; V2 = Socioeconomic level; V3 = Overall mark in EGB; V4 = Verbal aptitude; V5 = Numerical aptitude; V6 Reasoning; V9 = Perception of the instructional characteristics of the school; V12 = Initial self-concept; V13 = Initial motivation; V14 = Instructional factor; V15 = Regulative factor; V17 = Final self-concept; V18 = final motivation; V20 = final mark in Natural Science; V21 = final mark in Mathematics; V22 = final mark in Language; V23 = final mark in History; V24 = final mark in Foreign Language E = errors associated to the observed variables; F1 = Sociocultural latent variable; F2 = Intelligence and previous achievement; F3 = Initial personal latent variable; F5 = Instructional latent variable; F7 = Final personal latent variable; F8 = Final achievement latent variable; D5 = error of the F5 latent prediction variable; D7 = Prediction error of F7; D8 = Prediction error of F8 (final achievement); \* = Variances of the exogenous latent variables.

The influence of personal variables on academic achievement were further shown by Bandalos *et al* (1995) and Marsh and Yeung (1997). The former found that achievement in mathematics was caused by mathematics self-concept, attributions of failure and general test anxiety. Marsh and Yeung's model, on the other hand, provided support of a reciprocal effect between academic self-concept and academic achievement. In other words, prior academic achievement affects subsequent academic self-concept and prior academic self-concept affects subsequent academic achievement.

Similar developments occurred in the determination of variables that influence attitudes toward science. Since only a few models investigated all the determinants of science attitudes and achievement, and as such few models could actually be compared one with the other, a summary of important paths is discussed. In addition to studies that used structural equation modelling in their analysis of data, results of investigations discussed in chapter three will also be reported. The latter studies will serve as evidence to the effect that a *linear* relationship does exist or not.

#### 4.4.1 THE HOME VARIABLES - SCIENCE ACHIEVEMENT PATH

From an analysis of research results in the literature, the influence of the home have been operationalized in many ways. Consequently, the home (as a latent variable) has been represented by a number of indicator variables, namely parent education, parent occupation, parental socioeconomic status, parental involvement, family support of science, parents' attitudes toward science, parenting styles, parental beliefs and the like. On the other hand, science achievement have been represented by standardised achievement tests (SAT), school science achievement tests, science grade level (grade point average), tests of general science, biology, chemistry, physics and earth science, and tests that measure the scientific literacy level of students.

The relationship (correlation) between home variables and science achievement have been reported in chapter three and a summary thereof is presented in table 4.1. Table 4.1 seems to indicate that a linear relationship between home variables and science achievement does exist.

Causal studies support the inference that home variables influence science achievement. Home variables have been shown to have both direct and indirect effects on science achievement. Keeves (1974:20) found direct effects of home processes (0,13)<sup>1</sup> and home attitudes (0,13) on students' final science achievement. Schibeci and Riley (1986:185) found direct effects of the home environment variable (0,13) and parent education (0,22) on science achievement. The time spent by students doing homework had an indirect effect on science achievement through perceptions of instruction and attitude towards science. Both structural equation models of Reynolds and Walberg (1991:103; 1992:379) show

---

<sup>1</sup>Unless otherwise indicated, values in brackets are the path coefficients of Structural Equation Models (SEMs). These values differ from regression coefficients and/ or correlations.

indirect causal effects of the home environment variable on final science achievement. In both cases, the mediating variables are initial achievement and motivation.

Based on these results, the following hypothesis is postulated:

**HYPOTHESIS:** *HOME variables affect students' final achievement positively and directly.*

**Table 4.1 Summary of the relationship between home variables and science achievement**

AUTHOR	RELATIONSHIP	CORRELATION
Fleming & Malone 1983	SES (income) x science achievement	$\hat{r} = 0.25$
	SES (income) x high school science achievement	$\hat{r} = 0.30$
Staver & Walberg 1986	SES composite x science achievement	$r = 0.35$
	Home activities x science achievement	$r = 0.26$
	Parents' interest x science achievement	$r = 0.24$
	Homework x science achievement	$r = 0.21$
Schibeci & Riley 1986	Parents' education x science achievement	$r = 0.38$
	Home environment x science achievement	$r = 0.35$
Keeves 1974	Home environment indices x achievement	$r = 0.35$ to $0.55$
Simpson & Oliver 1990	Family support of science x semester grade	$r = 0.01$ to $0.05$
	Family support of science x standard achievement	$r = 0.10$
Tamir 1989	SES (composite) x science achievement	$r = 0.21$
Tamir 1987	Home variables (composite) x science achievement	$r = 0.13$ to $0.16$
Germann 1994	Parents' education x science process skills	$r = 0.37$

#### 4.4.2 THE HOME- PERSONAL- ABILITY - ACHIEVEMENT PATH

The latent PERSONAL variable is represented in the literature by the following indicator variables: (academic) self-concept, (achievement) motivation, gender and ethnicity (race). These indicator variables were described in chapter three but the relationships reported there were in regard to students' science achievement and attitudes. ABILITY, on the other hand, is represented in the literature as a students' mark (grade) in the last examination or test (prior achievement). Also, various cognitive tests have been used to indicate students' ability in physical science, namely mathematics ability, language ability and several tests using Piaget's developmental theory.



Reynolds and Walberg (1991:103; 1992:379) found in their SEMs that indicators of home environment influence students' motivation to learn (0,154 and 0,25 respectively). Motivation then influence final achievement through prior achievement. This result, they aver, is consistent with Fishbein and Ajzen's (1975) theory of social behaviour in which motivation influence achievement behaviour (prior achievement). Prior achievement, in turn, influence subsequent achievement. Rennie and Punch (1991:203) found that previous achievement accounted for around 35% of the variance in subsequent science achievement. Significant path coefficients were also found for the influence of previous achievement on subsequent achievement by Adanez (1989:346), Schibeci (1989:20), Keeves (1974:20), and Castejon & Vera-Munoz (1996:25).

Schibeci and Riley (1986:185) found that home variables influence achievement indirectly through motivation. These authors also found that motivation correlated with home environment ( $r = 0,17$ ) and parent education ( $r = 0,15$ ). Furthermore, the self-concept (self-confidence) correlated positively with the home environment ( $r = 0,15$ ) and parent education ( $r = 0,17$ ). Maqsd and Khaliq (1991:382) reported a correlation of 0,29 between the self-concept of boys and parental socioeconomic status whereas Welch, Anderson and Harris (1982:149) found a correlation of 0,18 between ethnicity and parent education.

The findings above indicates that home variables influence personal variables which in turn influence students' initial achievements. Home variables, however, also have a direct influence on students' abilities. Using SEMs, Reynolds and Walberg (1991, 1992) found path coefficients of 0,503 and 0,54, respectively, between home environment and initial achievement (ABILITY). A number of theoretical studies also reported significant correlations between home variables and children's abilities. These studies are summarised in table 4.2.

**Table 4.2 Summary of the relationship between home variables and ability variables**

AUTHOR(S)	RELATIONSHIP	CORRELATION (r)
Fleming & Malone 1983	SES x cognitive development	$\bar{r} = 0.28$
Germann 1994	Parents' education x cognitive development	0.47
	Parents' education x academic ability	0.42
Young et al 1996	Home environment x prior achievement	0.37
White 1982	Home atmosphere x cognitive skills	0.58

The findings above imply that home variables have a direct influence on personal and ability variables. Personal variables in turn influence ability variables directly. Also, ability variables influence students'

final achievement positively and directly. Since personal variables influence students' final achievement directly (see section 4.4.5), home variable have an indirect influence on final achievement through personal and ability variables. Based on these findings, the following hypothesis is postulated:

**HYPOTHESIS:** *HOME variables affect the PERSONAL and ABILITY variables positively and directly. In addition, HOME variables affect students' final achievement indirectly through motivation (PERSONAL variable) and initial achievement (ABILITY).*

#### **4.4.3 THE HOME VARIABLES - ATTITUDE TOWARDS SCIENCE PATH**

The latent variable ATTITUDE TOWARDS SCIENCE is represented in the literature by the following indicator variables: enjoyment of science, usefulness of science to student, students' perception of science as a male domain, students' interest in science, students' attitudes toward scientists and science careers, students' perceptions of parental attitudes toward science, students' expectations of doing well in science, and the like. Studies that investigated the linear relationship between home variables and students' attitudes toward science yielded mainly positive correlations (see table 4.3).

Studies that made use of SEMs also found significant path coefficients from home variables to attitude towards science. Germann (1994:773) found a path coefficient of 0.24 between parents' education and attitude towards science. Reynolds and Walberg (1992:379) reported a path value of 0.17 between home environment and students' initial attitudes toward science. Home environment variables also had an indirect effect on final attitudes through initial attitudes. Based on these findings the following hypothesis is postulated:

**HYPOTHESIS:** *HOME variables influence ATTITUDE TOWARDS SCIENCE directly and positively.*

**Table 4.3 Summary of the relationship between home variables and attitude towards science**

AUTHOR	RELATIONSHIP	CORRELATION (r)
Schibeci & Riley 1986	Home environment x usefulness of science	0.16
	Home environment x enjoyment of science	0.13
	Parent education x usefulness of science	0.10
	Parent education x enjoyment of science	0.13
Germann 1994	Parents' education x attitude towards science	0.20
Fleming & Malone 1983	SES (income) x science attitude	$\bar{r} = 0.03$
Haladyna et al 1982	SES x attitude towards science	-0.08 to 0.01
	Parental involvement x attitude towards science	0.07 to 0.25
	Parental concern x attitude towards science	-0.03 to 0.15
	Parental: school importance x attitude towards science	-0.02 to 0.12
Simpson & Oliver 1990	Family general x attitude towards science	0.130 to 0.157
	Family science x attitude towards science	0.483 to 0.540
	Father's attitude towards science (same gender) x attitude towards science	0.393 to 0.458
	Father's attitude towards science (opposite gender) x attitude towards science	0.340 to 0.412
	Mother's attitude towards science (same gender) x attitude towards science	0.381 to 0.420
	Mother's attitude towards science (opposite gender) x attitude towards science	0.339 to 0.409
Keeves 1974	Home structure x science attitude	0.20
	Home attitude x science attitude	0.19, 0.28
	Home process x science attitude	0.16, 0.25

#### 4.4.4 THE PERSONAL VARIABLES - ATTITUDE TOWARDS SCIENCE PATH

In chapter three it was shown that personal variables (gender, race, self-concept, motivation) are related to students' attitudes toward science. The results of theoretical research investigations in this domain are summarised in table 4.4.

**Table 4.4 Summary of the relationship between personal variables and attitude towards science**

AUTHOR	RELATIONSHIP	EFFECT SIZE
Weinburgh 1995	gender (M/F) x attitude towards science gender (M/F) x attitude toward biology gender (M/F) x attitude toward general science gender (M/F) x attitude toward physics	$\Delta = 0,20$ $\Delta = 0.03$ $\Delta = 0.34$ $\Delta = 0.12$
Young et al 1996	gender x science attitude academic motivation x science attitude	$\Delta = 0.17$ $\Delta = 0.22$
Fleming & Malone 1983	gender (M/F) x science attitude race (White/Black) x science attitude gender (M/F, primary school) x science attitude gender (M/F, high school) x science attitude gender (M/F, middle school) x science attitude gender (M/F) x attitude toward general science gender (M/F) x attitude toward chemistry gender (M/F) x attitude toward physical science	$\Delta = 0,08$ $\Delta = 0.10$ $\Delta = 0,18$ $\Delta = 0.12$ $\Delta = 0.11$ $\Delta = 0.37$ $\Delta = 0.02$ $\Delta = 0.09$
Steinkamp & Maehr 1983	gender (M/F) x attitude toward biology gender (M/F) x attitude toward chemistry gender (M/F) x attitude toward physics	$\bar{r} = -0.11$ $\bar{r} = -0.25$ $\bar{r} = -0.01$
Simpson & Oliver 1990	gender (M/F) x attitude towards science science self-concept x attitude towards science general self-concept x attitude towards science motivation x attitude towards science	$r = -0.053$ to $-0.059$ $r = 0.586$ to $0.594$ $r = 0.133$ to $0.151$ $r = 0.367$ to $0.390$
Germann 1994	gender x attitude towards science	$r = -0.14$
Napier & Riley 1985	science self-concept x science enjoyment science self-concept x usefulness of science student motivation x science enjoyment student motivation x usefulness of science	$r = 0.53$ $r = 0.38$ $r = 0.53$ $r = 0.51$

The direction of the personal-attitude relationship is provided in studies employing SEMs. Both Germann (1994:773) and Schibeci and Riley (1986:185) found a gender to attitude effect size of  $-0,11$ . Similarly, Keeves (1974:20) found a path coefficient of  $-0,20$  and Schibeci (1989:21) reported a path value of  $-0,17$ . Turning to other personal indicator variables, Adanez (1989:346) found that academic self-image influence attitude towards school ( $0,308$ ) whereas Bandalos *et al* (1995:619) found that mathematics self-concept influence students' perceived self-efficacy ( $0,583$ ) and test anxiety ( $-0,351$ ). Reynolds and Walberg (1992:379) found that motivation influences initial attitudes toward science ( $0,33$ ). Since a number of personal variables seem to influence students' attitudes toward science, the following hypothesis is postulated:

**HYPOTHESIS:** *PERSONAL variables influence students' ATTITUDES TOWARD SCHOOL directly.*

The sign of the above relationship is particularly difficult to hypothesise since the relationships with gender and anxiety are negative but the ones with self-concept and motivation are positive. Because the latter relationships seem to be stronger than the relationship with gender, a positive sign in the relationship between personal variables and attitude towards science can be expected. To further circumvent the sign of the path, separate SEMs can be constructed for boys and girls.

#### 4.4.5 THE PERSONAL VARIABLES - ACHIEVEMENT PATH

Personal variables (gender, race and ethnicity, self-concept and motivation) are related to students' initial and final achievement in science (see chapter 3). Table 4.5 illustrates this assertion.

In addition, there are studies showing that personal variables have a causal effect on science achievement. Schibeci and Riley's (1986:185) model show a path value of  $-0,22$  between gender and science achievement and a value of  $0,27$  between race and science achievement. Bandalos *et al* (1995:619) found that mathematics self-concept influences achievement directly and positively ( $0,405$ ). Motivation, on the other hand, influence achievement indirectly through instructional processes (Reynolds & Walberg 1991:103; 1992:379). From these studies it can be postulated that personal factors influence achievement directly. Here also, the sign caused by gender could be circumvented by constructing two models, one for each gender.

**HYPOTHESIS:** *PERSONAL variables influence students' SCIENCE ACHIEVEMENT directly.*

**Table 4.5 Summary of the relationship between personal variables and science achievement**

AUTHOR	RELATIONSHIP	EFFECT SIZE
Simpson & Oliver 1990	science self-concept x science achievement	$r = 0.235$
	achievement motivation x science achievement	$r = 0.116$
	gender x science achievement	$r = 0.101$
	race x science achievement	$r = -0.077$
Schibeci & Riley 1986	gender x science achievement	$r = -0.25$
	race x science achievement	$r = 0.30$
	self-confidence x science achievement	$r = 0.16$
	motivation x science achievement	$r = 0.31$
Fleming & Malone 1983	gender (M/F) x science achievement	$\Delta = 0.16$
	race (white/black) x science achievement	$\Delta = 0.41$
Tamir 1989	gender x science achievement	$r = -0.20$
	interest/motivation x science achievement	$r = 0.36$
Steinkamp & Maehr 1983	gender (M/F) x physics achievement	$\Delta = 0.25$
	gender (M/F) x chemistry achievement	$\Delta = 0.01$
	gender (M/F) x general science achievement	$\Delta = 0.19$
Lee & Burkam 1996	females x physical science achievement	$r = -0.225$
	blacks x physical science achievement	$r = -0.530$
Napier & Riley 1985	student motivation x science achievement	$r = 0.26$
	science self-concept x science achievement	$r = 0.17$
Young et al 1996	gender x science achievement	$r = 0.07$
	motivation x science achievement	$r = 0.06$
Germann 1994	gender x science process skills achievement	$r = -0.15$

#### 4.4.6 THE SCHOOL - ACHIEVEMENT PATH

School variables refers to variables such as instructional processes in the classroom, classroom climate, school climate, classroom interactions, teacher characteristics and the like. The influence of the school variables on students' achievement in science from a theoretical perspective was discussed in section 3.4.3.1 and a summary is provided in table 4.6.

**Table 4.6 Summary of the relationship between school variables and science achievement**

AUTHOR	RELATIONSHIP	EFFECT SIZE
Schibeci & Riley 1986	perception of teacher support x achievement	r = 0.11
	perception of teacher enthusiasm x achievement	r = 0.10
Reynolds & Walberg 1991	classroom environment x final achievement	r = 0.384
	classroom environment x initial achievement	r = 0.390
	instructional time x final achievement	r = 0.529
	instructional quality x final achievement	r = 0.295
Reynolds & Walberg 1992	classroom environment x final achievement	r = 0.335
	instructional time x final achievement	r = 0.297
	instructional quality x final achievement	r = 0.173
Lee & Burkam 1996	school SES x physical science achievement	$\Delta = 0.36$
Staver & Walberg 1986	school environment (order, misbehaviour, facilities, safety, lack of stress) x science achievement	r = -0.16 to 0.16
Welch et al 1982	school effects (semesters math courses completed) x mathematics achievement	r = 0.73
Druva & Anderson 1983	teacher characteristics x science achievement	r = 0.16 to 0.46
Simpson & Oliver 1990	class climate x science achievement	r = 0.11
	curriculum x science achievement	r = 0.071
	physical environment x science achievement	r = 0.016
	teacher x science achievement	r = 0.092
	school x science achievement	r = 0.124
Tamir 1989	school effects x science achievement	r = 0.48
Napier & Riley 1985	teacher support x science achievement	r = 0.15
	teacher enthusiasm x science achievement	r = 0.12
Young et al 1996	instructional quality x science achievement	r = 0.13
	class environment x science achievement	r = 0.28
	instructional time x science achievement	r = 0.19

Methodologically, there is evidence that school variables influence students' science achievement. Biniaminov and Clasman's (1983:261) model depicts school achievement in Israel as caused by teachers' teaching experience in the same school (0,339), level of disadvantaged students (-0,141) and

level of fiscal resources of the school (-0,441). Keeves (1974:20) found that classroom structure (0,19) and classroom interaction (0,09) influence students' final achievement in science. Castejon and Vera-Munoz (1996:25) found that the regulative factors of the school (0,080) influence academic achievement. Reynolds and Walberg (1991:103) reported an effect on achievement by both the classroom environment (indirect effect) and instructional quality (direct effect) variables. Finally, Schibeci and Riley (1986:185) found that students' perceptions of instruction had an indirect effect (through attitudes) on their science achievement scores.

The following hypothesis can thus be deduced from the findings above:

**HYPOTHESIS:** *SCHOOL variables have a direct and positive influence on students' SCIENCE ACHIEVEMENT.*

#### **4.4.7 THE SCHOOL- ATTITUDE TOWARDS SCIENCE PATH**

The school plays a central role in forming students' attitudes toward science (see section 3.4.3.2). Table 4.7 gives a summary of correlational studies in this regard. Although few studies investigated the causal relationship between school variables and attitude towards science, such a relationship is postulated in this study. Support to this hypothesis is derived from two studies which found significant school effects on students' attitudes toward science. First, Keeves (1974:20) found that interactions in the classroom influence students' final attitudes toward science. Second, Schibeci and Riley (1986:185) found a direct and positive effect of students' perceptions of instruction on their attitudes toward science (0.68). Consequently the following hypothesis is postulated.

**HYPOTHESIS:** *SCHOOL variables influence ATTITUDE TOWARDS SCIENCE directly and positively.*



**Table 4.7 Summary of the relationship between school variables and attitude towards science**

AUTHOR	RELATIONSHIP	CORRELATION
Schibeci & Riley 1986	teacher support x usefulness of science	0.44
	teacher support x enjoyment of science	0.51
	teacher enthusiasm x usefulness of science	0.40
	teacher enthusiasm x enjoyment of science	0.46
Reynolds & Walberg 1992	class environment x final attitude towards science	0.146
	instructional time x final attitude towards science	0.222
	instructional quality x final attitude towards science	0.057
	science	
Maqsd & Khalique 1991	school alienation x boys' mathematics attitude	-0.40
Simpson & Oliver 1990	class climate x attitude towards science	0.627 to 0.654
	other students x attitude towards science	0.148 to 0.163
	curriculum x attitude towards science	0.660 to 0.690
	physical environment x attitude towards science	0.437 to 0.472
	teacher x attitude towards science	0.483 to 0.525
	school x attitude towards science	0.336 to 0.375
Napier & Riley 1985	teacher support x science enjoyment	0.42
	teacher support x usefulness of class	0.37
	teacher enthusiasm x science enjoyment	0.46
	teacher enthusiasm x usefulness of class	0.38
Young et al 1996	instructional time x attitude towards science	0.15
	instructional quality x attitude towards science	0.05
	class environment x attitude towards science	0.11
Mordi 1991	teacher preparation x attitude towards science	0.53
	experimental work x attitude towards science	0.16
	use of library books x attitude towards science	0.12
	teacher knowledge x attitude towards science	0.20
	content decision making x attitude towards science	0.22

#### 4.4.8 THE ATTITUDE TOWARDS SCIENCE - ACHIEVEMENT PATH

In section 3.3.7, the relationship of science achievement and attitude toward science was discussed. Studies that reported effect sizes are shown in table 4.8. Analysis of table 4.8 shows that the correlations are low, varying from 0,2 to 0,3.

**Table 4.8 Summary of the relationship between attitude towards science and science achievement**

AUTHOR	RELATIONSHIP	EFFECT SIZE
Wilson 1983	attitude x science achievement	$\bar{r} = 0.16$
Steinkamp & Maehr 1983	boys' affect x science achievement	$\bar{r} = 0.19$
	girls' affect x science achievement	$\bar{r} = 0.18$
Weinburgh 1995	science attitude x science achievement (boys)	$\bar{r} = 0.50$
	science attitude x science achievement (girls)	$\bar{r} = 0.55$
	science attitude x science achievement (gender)	$\Delta = 0.2$
Rennie & Punch 1991	enjoy science x science achievement	$r = 0.27$
	usefulness of science x science achievement	$r = 0.17$
House 1993	perception of ability x science achievement	$r = 0.193$
Napier & Riley 1985	science enjoyment x science achievement	$r = 0.18$
	usefulness of class x science achievement	$r = 0.19$
Germann 1988	science attitude x science achievement	$r = 0.24, 0.31$
Reynolds & Walberg 1992	initial attitude x initial achievement	$r = 0.343$
	initial attitude x final achievement	$r = 0.314$
	final attitude x initial achievement	$r = 0.372$
	final attitude x final achievement	$r = 0.314$
Germann 1994	attitude x science process skills achievement	$r = 0.27$
Schibeci & Riley 1986	usefulness of science x science achievement	$r = 0.25$
	enjoyment of science x science achievement	$r = 0.22$
Young et al 1996	science attitude x science achievement	$r = 0.24$
Oliver & Simpson 1988	science attitude x science achievement	$r = 0.03$
Maqsd & Khalique 1991	math attitude x math achievement (boys)	$r = 0.31$
	math attitude x math achievement (girls)	$r = 0.49$

As mentioned in section 3.3.7, there are differing opinions concerning the direction of the attitude-achievement relationship. Two studies were found that supported the attitude→achievement path. Germann (1994:773) found that science attitudes have a direct effect on students' science process skills achievements (-0,10). Schibeci & Riley (1986:183) found a significant effect for the path attitude→achievement and not for the path achievement→attitude. These authors, however, do not insist on the above direction as evidenced in the following statement. "No unequivocal claim . . . may be made for the chronology of the three latent variables, student perceptions of science instruction, student attitudes, and student achievement" (page 185).

A number of studies, on the other hand, reported that science achievement influence attitudes toward science. Rennie and Punch (1991:207), using multiple linear regression analysis, found that there is a stronger influence by achievement on later affect than by affect on later achievement. Also, science-related affect was found to be more related to previous achievement than to subsequent achievement. These findings were also found in studies employing SEMs. Schibeci (1989:20) found that initial achievement influence final science related attitude and general attitude. Keeves (1974:20) also reported that students' final attitudes are influenced by their initial attitudes and their final achievement in science. Reynolds and Walberg (1992:378) summarised their findings as follows: "Prior science attitudes and achievement had significant direct effects on science attitude. ... The positive influence of prior achievement on later attitude paired with the negligible influence of prior attitude on later achievement suggests that the causal direction between achievement and attitude is recursive rather than reciprocal or in the reverse direction. That is, for this sample achievement more likely causes attitude rather than the reverse".

In conclusion, although a reciprocal effect between attitude towards science and science achievement seems possible, the results of previous research imply a causal effect from initial achievement (ABILITY) to attitude towards science. Consequently, the following hypothesis is postulated.

**HYPOTHESIS:** *ABILITY has a direct and positive effect on ATTITUDE TOWARDS SCIENCE*

#### **4.5 THE PSYCHOLOGICAL AND SOCIAL SEM OF SCIENCE ACHIEVEMENT AND ATTITUDE**

Now that the most important paths in previous research investigations have been identified and analysed, a theoretical structural equation model (SEM) of psychological and social factors influencing science achievement and attitude is presented (see figure 4.7). Only latent variables are given in figure 4.7, the indicator variables (as measured in this thesis) are described in chapter five.

**Figure 4.7 The theoretical SEM of science achievement and attitude (psychological and social factors)**

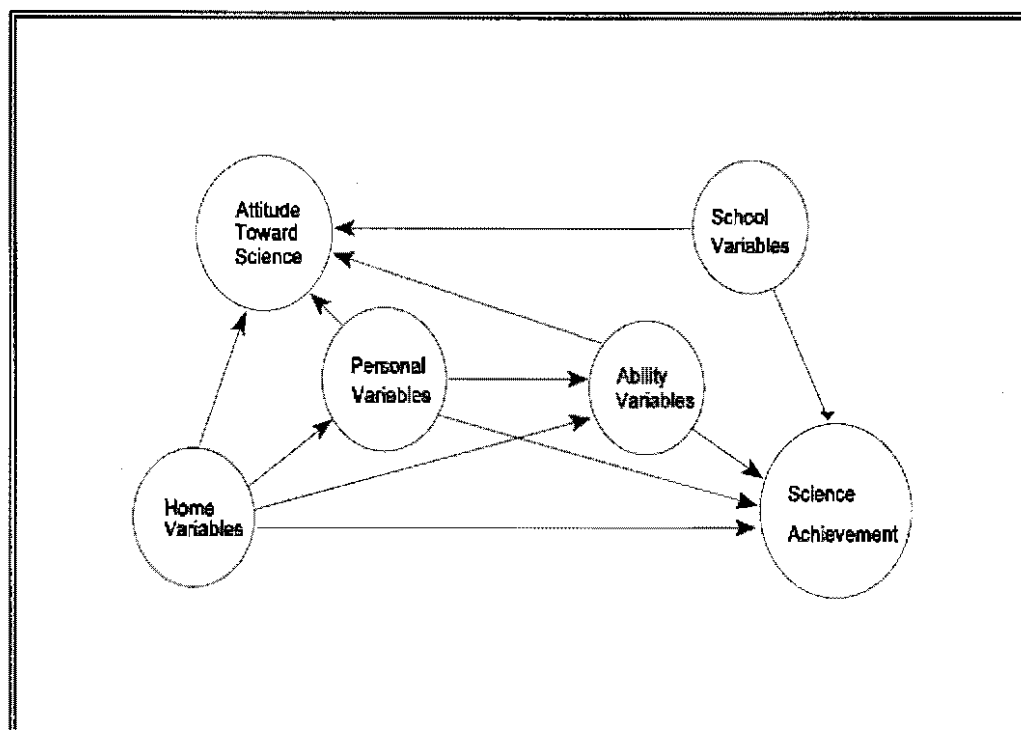

In the construction of the above theoretical model, the following processes were followed.

- (a) The model was constructed from all the hypotheses postulated in section 4.4. In other words, the model is a theoretical product based on the results of a large number of studies. The latent variables in the model represent a number of observable variables identified in chapter three as important predictors of science achievement and attitudes. As such, most "important causes" have been incorporated into the model - a prerequisite that makes models testable (Sarıs & Stronkhorst 1984:35).

- (b) Since the SEM was built from rigorous theoretical grounds, a longitudinal design for testing the model is not necessary and is therefore not followed in this study. The theoretical SEM model is therefore suitable for testing using cross-sectional data.
- (c) For the sake of parsimony, a number of additional effects that could have been suggested were omitted. These additional effects were hypothesised to have small or negligible effects. In addition, the construction of a simple model was aimed at from the onset. Saris and Stronkhorst (1984:35) suggested the following criteria for simplifying models:
  - (i) Common causes of variables which are related by direct causal effects cannot be left out of the theory.
  - (ii) Intervening variables can be omitted from the theory without harming the test procedures of causal hypotheses in the theory.
  - (iii) Variables which influence either cause or effect variables but not both, can be omitted without harming the test procedures of causal hypotheses in the theory.
- (d) Cognisance of the fact that sources from overseas countries were referred to in this study were born in mind by modifying or omitting several paths and/or indicator variables. For example, it would be futile to measure instructional time in urban black schools. The items of this variable (see Reynolds & Walberg 1991:101) refers to matters such as parental report of weekly homework in hours and student absenteeism. Parental involvement in black schools has not shaped up yet to an educationally acceptable level and subject teachers usually do not keep records of absent children in each class they teach. As such attempting to measure such activities will introduce a lot of measurement error. Consequently the model in figure 4.7 is devoid of all variables deemed unsuitable or irrelevant and is particularly suited to determine causal factors of black South African urban science students' outcomes.

#### **4.6 CONCLUSION**

Methodological studies reviewed in this chapter confirmed most relationships found in the theoretical studies (chapter three). Methodological studies, however, shed more light into the mechanisms through which predictor variables influence science achievement and attitude. These studies also showed the relationships among predictor variables.

In addition to yielding conceptually clearer theories on the determinants of science outcomes, the structural equation models reviewed in this chapter catered for the measurement of hypothetical concepts or constructs (latent variables), measurement error, reciprocal and joint effects, and unequal

interval scaling of independent and dependent variables. Some of the studies also made use of the latest statistical procedures (LISREL and EQS) that developed efficient testing and estimation of structural equation models. The effect being a clearer and accurate understanding of the mechanism through which scholastic outcomes are affected.

From the above mentioned studies, and those in chapter three, a theoretical model was developed (figure 4.7). The model indicates psychological and social factors that influence the science outcomes of students, particularly urban black secondary school students in South Africa. The model is based on the following hypotheses.

- (1) Home variables have a direct effect on the child's personal variables, ability variables, science achievement and attitude towards science. In addition, home variables have an indirect effect on science achievement and attitude through the mediated effect of personal and ability variables.
- (2) School variables have a direct effect on both attitude towards science and science achievement.
- (3) Personal and ability variables have a direct influence on both attitude towards science and science achievement. In addition, personal variables have an indirect influence on both attitude towards science and science achievement through the mediated effects of ability variables.
- (4) Gender influences most variables in the model and as such two models are hypothesised, one for boys and the other for girls.

The above theoretical model will be tested by collecting data from urban black secondary school children in Johannesburg, Gauteng. The planning, design and execution of the data gathering process is the subject of the next chapter.

## CHAPTER 5

### THE EMPIRICAL INVESTIGATION: PLANNING, METHOD, EXECUTION AND RESULTS

#### 5.1 INTRODUCTION

A number of psychological and social factors related to physical science achievement and attitude were identified in chapter three. These factors were then used in chapter four to build a theoretical model. There is a need, however, that the model be tested against data from secondary school children in urban townships.

The main purpose of this chapter was to outline the research design and results obtained in the estimation of the theoretical model proposed in chapter four. The data used to test the model were derived from a questionnaire which was administered to secondary school students. The questionnaire included items used to measure all the latent factors and observable variables as given in the theoretical model.

#### 5.2 OBJECTIVES OF THE EMPIRICAL INVESTIGATION

The objectives of the empirical investigation were:

- to investigate the factorial structure of the instruments used in the questionnaire through factor analysis; and
- to test (estimate) a theoretically developed structural equation model of science achievement and attitude.

To achieve the stated objectives, these steps were followed:

- A questionnaire was constructed to measure the dependent variables (science achievement and attitude towards science) and the independent variables (home, personal, school and ability latent factors). The questionnaire was also used to determine the age, sex, and school standard of students as well as other background information.
- The measurement model (see section 4.3.3) was tested to determine the adequacy of the indicator (observed) variables in representing the theoretical model.
- The theoretical model was fit to the data (that is, estimated) and compared with plausible alternative models, as required in the model building process.

### 5.3 PLANNING OF THE EMPIRICAL INVESTIGATION

#### 5.3.1 THE RESEARCH GROUP

The research group consisted of secondary school students doing physical science in standards seven and eight. It has been indicated by Borg and Gall (1989:179-80) that sampling bias is a factor that greatly weakens educational research. To minimize sampling bias, a random sampling technique (cluster sampling) and a large sample size (N = 548) were used.

To draw a sample of between 500 and 600 students from schools in SOWETO, Johannesburg, a single-stage simple random sampling of clusters was used (Pedhazur & Schmelkin 1991:334-336). Three schools (out of a total of approximately 65 schools) were randomly selected and all students in standard seven and eight were used as subjects for the empirical investigation. The profile of the subjects is given in tables 5.1 to 5.4.

**Table 5.1 Distribution of subjects according to school and grade level**

SCHOOL	A	B	C <sup>a</sup>	D	TOTAL
GRADE 9	160	232	27	<sup>b</sup>	419
GRADE 10	43	39	21	23	126
SUBTOTAL	203	271	48	23	545
missing observations = 3				TOTAL	548

<sup>a</sup> Questionnaires were administered to two classes only. The other three grade nine classes were virtually empty by the time I reached them. I subsequently drew another school randomly from the original list and arranged for the administration of questionnaires.

<sup>b</sup> I was restricted to giving out questionnaires at one time to all classes. As such, after dishing out the questionnaires, I could attend to one class only. The majority of questionnaires were thus incompletely filled. These questionnaires were left out of the analysis since the target sample of between 500 and 600 was reached.

**Table 5.2 Distribution of the subjects according to grade level and gender**

GRADE	9	10	TOTAL	missing observations = 3
FEMALE	215	67	282	
MALE	203	59	262	
TOTAL	419	126	545	



**Table 5.3** Age distribution of the subjects

AGE (YEARS)	FREQUENCY	PERCENTAGE
13	6	1.1
14	69	12.6
15	125	22.8
16	124	22.6
17	105	19.2
18	57	10.4
19	38	6.9
20	16	2.9
21	3	0.5
22	1	0.2
23	1	0.2
0-5	3	0.6
<b>TOTAL</b>	<b>548</b>	<b>100</b>

**Table 5.4** Distribution of subjects according to Ethnicity

LANGUAGE GROUP	FREQUENCY	PERCENTAGE
<b>NORTH SOTHO</b>	111	20.3
<b>SOUTH SOTHO</b>	159	29.0
<b>TSWANA</b>	117	21.4
<b>ZULU</b>	128	23.4
<b>XHOSA</b>	11	2.0
<b>TSONGA</b>	3	0.5
<b>VENDA</b>	2	0.4
<b>SWAZI</b>	12	2.2
<b>NDEBELE</b>	4	0.7
<b>TOTAL</b>	<b>548</b>	<b>100</b>

### 5.3.2 PERMISSION TO USE THE SCHOOLS FOR THE INVESTIGATION

Permission was granted by the principals that students should fill in the questionnaire during school hours. Permission was subject to the following conditions:

- The investigator should administrate the questionnaire personally so that the school programme should not be disturbed.
- The name of the schools, the principals, teachers and pupils should not be mentioned nor identified in the research report.
- The information obtained from the questionnaire responses should be presented in such a way that no injustice will be done to the participants.

### 5.3.3 INSTRUMENTS

In chapter four (section 4.5) a structural equation model showing the determinants of physical science achievement and attitude was constructed. The structural equation model contained six latent factors, namely the home variables factor, the personal variables factor, the attitude towards science factor, the school variables factor, the ability variables factor and the science achievement factor. As stated in chapter four (section 4.3.3) latent factors need to be measured (each) by a number of indicator variables. The indicator variables, according to Gable (1986:15), are operational constructs.

Kerlinger (1986:28) asserts that an **operational definition** assigns meaning to a construct or a variable by specifying the activities or "operations" necessary to measure it. In other words, an operational definition gives meaning to a variable by spelling out what the investigator must do to measure it. Operational definitions, according to Kerlinger, are indispensable because they are bridges between the theory - hypothesis - construct level and the level of observation.

Kerlinger (1986:29) identified two types of operational definitions: measured and experimental. The former describes how a variable is measured whereas the latter spells out the details (operations) of the investigator's manipulation of a variable. The measured operational definitions of the indicator variables used in this study are given below. That is, the manner in which the variables will be measured and the description of the characteristics of the variables are given.

### 5.3.3.1 OPERATIONAL VARIABLES OF THE HOME LATENT FACTOR

From the literature study (see chapters three and four) it was shown that three aspects of the home are particularly related to children's science achievement and attitude, namely parental socioeconomic status, parental involvement with the child and parental attitudes toward science. The home environment latent factor was therefore measured by formulating items relating to these concepts. The variables used to measure these concepts are described below.

#### (a) SOCIOECONOMIC BACKGROUND

A brief Socioeconomic Background Scale requiring the subjects to give information on their parents' educational and occupational background as well as on some economic facilities available at home was constructed. Socioeconomic background data could be quantified according to the levels of educational, occupational and economic status of subjects' parents, and scores on the Socioeconomic Background Scale could range from 4 to 37. The higher the score, the higher the socioeconomic status.

The ten items used to measure socioeconomic status are given in full in appendix A. Table 5.5 list the relevant items of the socioeconomic background scale in the questionnaire (appendix A).

#### (b) PARENTAL INVOLVEMENT AND ATTITUDE

Parental involvement measures whether parents help and participate in children's schooling. It also measures the atmosphere in the home, that is whether parents are authoritative or laissez faire. Authoritative parental styles were shown in the literature study as creating a conducive atmosphere in the home for academic self actualisation. A scale was found in the literature which measured these aspects of parental involvement, namely helping, controlling, supporting, and participating (Mau 1997). The scale contain fifteen items whose scores range from 15 to 60. See table 5.2 and appendix A for a full list of the items. Examples of adapted items in each of these four categories are given below.

**Helping:** *"My parents/guardians help me with my homework."*

**Controlling:** *"My parents/guardians limit my privileges when I get poor symbols."*

**Supporting:** *"I discuss my plans and preparation for tests with my parent(s) or guardian(s)."*

**Participating:** *"My parent(s) or guardian(s) attend school events in which I participate."*

Parental attitudes toward science measures perceived parental encouragement and expectation for the child to do well in physical science, parental encouragement to pursue a science career and parental competence in physical science. These aspects were shown in chapter three as being related to science achievement and attitude. The attitudes of the father and mother were measured separately, for example, *"my father/stepfather knows a lot about science"*. The highest score of either the mother or father was used as a measure of parental attitudes. The scores were then summed up to get a composite score (Hein & Lewko 1994), ranging from 4 to 16.

### 5.3.3.2 OPERATIONAL VARIABLES OF THE PERSONAL LATENT FACTOR

In addition to gender and ethnicity, motivation and self-concept were found in the literature study as playing an important role in students' science achievement and attitude. Scales used to measure these constructs are described below.

#### (a) MOTIVATION TO LEARN PHYSICAL SCIENCE

Motivation is a multidimensional construct (see chapter three). In this study those dimensions of motivation that are highly related to science achievement and attitude are selected for measurement, namely intrinsic motivation, persistence, achievement motivation and some general (residual) motivation.

For example, items that measure intrinsic motivation determine whether the student is prepared to do physical science on his/her own will and to get involved with the subject. A typical item in this regard is *"I do as little work as possible in physical science"*. For persistence, achievement motivation and residual motivation, typical items are, respectively: *"I try hard in physical science"*, *If I start a new physical science project, I finish it"*, and *"I try to do my physical science tasks fully"*. A total of fifteen items, with scores ranging from fifteen to sixty, were used. The items used here were previously used by Mellet (1986); Reynolds & Walberg (1992); Uguroglu, Schiller & Walberg (1981); and Uguroglu & Walberg (1986).

#### (b) PHYSICAL SCIENCE SELF-CONCEPT

From the literature study, it was found that science self-concept is related to science achievement more than, for example, general self-concept. As such, only science self-concept items were used in this empirical investigation. The items used were adapted from Uguroglu and Walberg (1986); Marsh & Yeung (1997); Marsh (1994); and Benson (1989). An example of an item measuring science self-concept is:

*"I have the ability to do well in physical science"*.

### 5.3.3.3 OPERATIONAL VARIABLES OF THE SCHOOL LATENT FACTOR

The school factor refers to all aspects of school life that are related to the physical science outcomes of students. These aspects include teacher characteristics, instructional time and general environmental factors in the school that have a bearing on learning.

#### (a) TEACHER CHARACTERISTICS

Fourteen items were constructed that measures the following:

- Teacher support, for example, "*my physical science teacher encourages me to be creative*".
- Teacher enthusiasm, for example, "*my physical science teacher makes science exciting*".
- Instructional quality, for example, "*we conduct experiments in our physical science class*". Instructional quality, according to Reynolds and Walberg (1992), refers to the extent to which physical science instruction focuses on investigative and inquiry learning. These aspects, they aver, appear to improve performance in science.

#### (b) INSTRUCTIONAL TIME

Instructional time is a measure of the amount of material (subject content) the student covers in school and at home by way of homeworks. Intuitively, students who receive less exposure in the content of the subject will find it difficult to achieve good marks in that subject. Three items were used to measure instructional time and a typical item is given below.

*"I attend all my physical science classes regularly".*

#### (c) SCHOOL ENVIRONMENT

The items used here were adapted from Staver and Walberg (1986) and measures the environment of the school by making use of three indicators:

- misbehaviour, for example, "*In our school, students disobey teachers*";
- facilities, for example, "*Our school library is functioning well*"; and
- safety at school, for example, "*I feel safe at school*".

#### 5.3.3.4 OPERATIONAL VARIABLES OF THE ATTITUDE TOWARDS PHYSICAL SCIENCE FACTOR

Attitude towards physical science is a multidimensional construct. In this study four dimensions of attitude towards physical science were measured, namely a general attitude towards physical science, the attitude towards the usefulness of physical science, the attitude towards physical science careers and courses and the attitude towards practical work in physical science.

##### (a) GENERAL ATTITUDE TOWARDS PHYSICAL SCIENCE

To measure a general attitude towards physical science, a scale developed by Germann (1988) for a general attitude towards science was adapted. This scale measures a single dimension of a general attitude towards science. Fourteen items were used which specifically measure students' feelings toward physical science as a school subject. A typical item is:

*"Physical science is fun".*

##### (b) USEFULNESS OF PHYSICAL SCIENCE

Four items ( $\alpha = 0,86$ ) were used by Reynolds and Walberg (1992) to measure this dimension of attitude towards science. These items were adapted to measure the usefulness of physical science, for example:

*"Physical science is useful in everyday problems".*

##### (c) ATTITUDE TOWARDS PHYSICAL SCIENCE CAREERS AND COURSES

Two items were used here: *"I would like to pursue Physical science as a career"* and *"I would be interested to study further in physical science."*

##### (d) ATTITUDE TOWARDS PRACTICAL WORK IN PHYSICAL SCIENCE

Three items were used to measure students' attitudes toward practical work (adapted from Du Toit et al 1992). A typical item is: *"I like practical work in Physical science"*.

#### 5.3.3.5 OPERATIONAL VARIABLES OF THE ABILITY LATENT FACTOR

The ability factor was measured with four items in this study. The items required students to report on how many times they failed previous grades/standards and on their marks in three subjects (Physical science, Mathematics and English). An example of one of these items is:

*"What percentage did you get for physical science in the last examination?"*

### 5.3.3.6 THE ACHIEVEMENT FACTOR

This is the final year end examination result of the student. The marks were obtained from official school records.

### 5.3.3.7 CONSTRUCTION OF ITEMS

The concepts necessary to establish the content and purpose of the individual items in the questionnaire were described in the preceding sections. Most of the items used in each category were previously used by researchers in the field who reported high reliabilities for their instruments. However, since conditions in other countries differ from ours, most items were reformulated to be relevant to South African conditions. For example, an item like "*I goof off in physical science class*" was changed to "*I fool around in physical science class*". Other items were originally formulated in Afrikaans and had to be translated.

All the items (except items measuring background data) were constructed so that respondents could indicate whether they agreed or disagreed with the given statement. In order to avoid a neutral position by respondents, a four point category ranging from "strongly agree" to "strongly disagree" was used. The items were scored as follows:

Strongly agree	= 4
Agree	= 3
Disagree	= 2
Strongly disagree	= 1

Negative items were scored in the opposite way, that is, strongly agree scored a one and strongly disagree scored a four. The items of all the instruments were then mixed and arranged into a questionnaire (see appendix A).

### 5.3.4 THE QUESTIONNAIRE

The nature of this empirical investigation required participation by many subjects. Otherwise the statistical analyses performed on the data would have been biased. To collect data from a large sample necessitated the use of a questionnaire. During the compilation of the questionnaire, the following properties of an effective questionnaire were kept in mind.

### 5.3.4.1 THE PROPERTIES OF AN EFFECTIVE QUESTIONNAIRE

"A questionnaire is designed in such a way that it answers specific research goals. Each question should therefore be carefully formulated. A questionnaire should not be evaluated globally, but each question must be carefully weighed to determine whether the response will help to provide the best answer to the research problem" (Jacobs, Oosthuizen, le Roux, Olivier, Bester & Mellet 1989:98).

The questions asked in the questionnaire must be carefully worded and related to the context of the research problem. Kerlinger (1986:444) sets the following criteria for each question or item:

- Is the question related to the research problem and research objectives?
- Is the type of question appropriate?
- Is the question clear and unambiguous?
- Is the question a leading question?
- Does the question demand knowledge and information that the respondent does not have?
- Does the question demand personal or delicate material that the respondent may resist?
- Is the question loaded with social desirability?

A questionnaire, according to Mellet (1986:182) must also have the following properties:

- The topic or theme must be such that the respondent sees it as important so that he/she will be prepared to cooperate in completing the questionnaire.
- It must be attractive, brief, and as easy as possible to fill in.
- Instructions should be given clearly at the beginning of the questionnaire.
- Questions should be phrased as objectively as possible.
- It should be possible to analyse and quantify the response data.
- The items must follow a logical order and should not ask for a moral or ethical standpoint.

### 5.3.4.2 FORMAT OF THE QUESTIONNAIRE

The questionnaire is made up of items of all the instruments described in section 5.3.3. The latter were used to collect data that will be used to test the theoretical model given in figure 5.1. Note that figure 5.1 is similar to figure 4.7. The two differ only in that indicator variables used to measure the latent factors in figure 4.7 are added in figure 5.1.



**Figure 5.1 A conceptual model showing psychological and social factors related to physical science achievement and attitude**

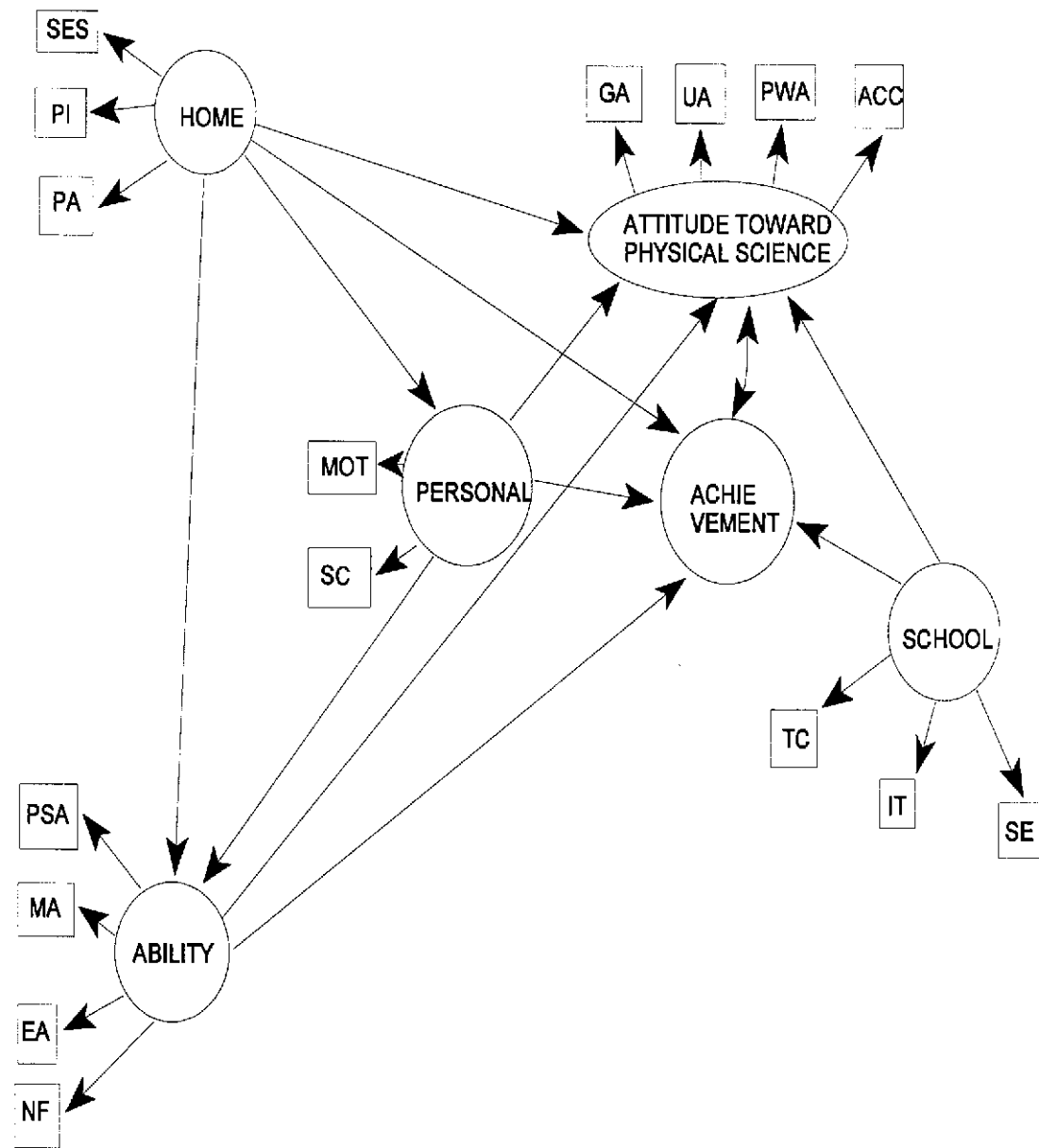

SES = socioeconomic status; PI = parental involvement; PA = parental attitudes; GA = general attitude toward physical science; UA = usefulness of science attitude; PWA = attitude toward practical work in physical science; ACC = attitude toward physical science careers and courses; MOT = motivation to learn physical science; SC = science self concept; TC = teacher characteristics; IT = instructional time; SE = school environment; PSA = physical science ability; MA = mathematics ability; EA = English ability; NF = number of failed grades.

Figure 5.1 indicates that there are six factors measured in this study, namely

- the home environment factor;
- the personal factor;
- the school factor;
- the attitude towards science factor;
- the ability factor; and
- the science achievement factor.

The items in the questionnaire used to measure the above factors (and their indicator variables) are summarised in table 5.5.

**Table 5.5 Format of the items used in the questionnaire**

LATENT FACTOR	INDICATOR VARIABLES	ITEMS IN THE QUESTIONNAIRE
HOME	Socioeconomic status	108, 109, 110, 111, 113, 114, 115, 116, 117, 118
	Parental Involvement & attitude	56, 77, 68, 83, 89, 62, 93, 87, 97, 76, 92, 95, 84, 72, 81, 4, 49, 27, 7, 43, 46, 15, 19
PERSONAL	Motivation	55, 60, 66, 74, 71, 8, 23, 10, 50, 12, 98, 85, 75, 70, 64
	Self-concept	61, 58, 13, 51, 14, 16, 38, 28, 18, 101, 100, 94, 90, 67, 80
	Gender	112
	Ethnicity	119
PHYSICAL SCIENCE ATTITUDE	Attitude Towards Physical Science	2, 30, 31, 17, 32, 11, 33, 35, 37, 39, 9, 40, 3, 41, 42, 1, 44, 54, 45, 34, 47, 24, 48
SCHOOL	Teacher characteristics	57, 78, 69, 82, 63, 88, 22, 36, 6, 25, 53, 99, 96, 91
	Instructional Time	102, 52, 26
	School Environment	59, 65, 73, 86, 79, 20, 29, 5, 21
ABILITY	Ability	104, 105, 106, 107
ACHIEVEMENT	final examination scores obtained from official school records	
TOTAL		119

#### **5.3.4.3 INSTRUCTIONS FOR THE COMPLETION OF THE QUESTIONNAIRE**

Written instructions on the first page of the questionnaire were given to respondents. The purpose was to make it clear to respondents what is expected from them and the manner in which they ought to fill in the questionnaire. The following information was provided to respondents:

- Respondents were told that they are not being tested and only their opinions are required. Since the answer requires opinions, there is no wrong or right answer.
- Respondents were urged to be honest in their response and to respond according to their own feelings.
- Respondents were reassured that their answers are confidential and no one else (the school or parents) will have access to their responses.
- Respondents were asked to make sure that they answer all questions.
- Respondents were urged to be free to ask if they do not understand any aspect or statement in the questionnaire.
- An example of how responses should be made was given.
- Finally, respondents were thanked in advance for their cooperation and asked to begin filling in the questionnaire.

#### **5.3.4.4 PRELIMINARY EVALUATION OF THE QUESTIONNAIRE**

The questionnaire was compiled and given to a number of teachers to make comments on the suitability of items, word difficulty, improvements, et cetera. Several items were modified from the input given by the teachers.

The questionnaire was then evaluated by professors at the University of South Africa (Faculty of Education) for construct validity, namely Professor Mellet, S.M and Professor Bester, G. Thereafter the questionnaire was evaluated by members of the Statistical Consultation Service of the department of Statistics at the University of South Africa. After making the necessary changes the final questionnaire contained items as in appendix A and table 5.5.

## **5.4 METHOD**

### **5.4.1 STATISTICAL TECHNIQUES**

#### **5.4.1.1 ITEM ANALYSIS**

Item analysis was carried out on each category of the questionnaire. For each item, the average, the standard deviation and Cronbach's alpha reliability coefficient was calculated for each of the various categories (fields) of the questionnaire individually. The purpose here is to determine whether the item correlates well with the particular field for which it was intended. Items that fail to show significant correlations with the intended field are then eliminated so as to obtain a higher reliability coefficient.

#### **5.4.1.2 FACTOR ANALYSIS**

The primary goal of factor analysis is to explain the covariances or correlations between many observed variables by means of relatively few underlying latent variables. It can therefore be classified as a data reduction technique.

Factor analysis can be approached in two ways, an exploratory and a confirmatory approach. Exploratory factor analysis (EFA) is the more traditional approach. The most distinctive feature of EFA, is that a model specifying the relationship between the latent variables and the observed variables is not required. The number of latent variables need not be predetermined, the measurement errors are not allowed to be correlated, and under-identification, which occurs when unique parameter estimates cannot be generated, is common (Bollen 1989:226-232).

In contrast, in confirmatory factor analysis (CFA), a model is constructed in advance, clearly identifying relationships and errors. The number of latent variables is set by the researcher, measurement errors are allowed to be correlated and parameter identification is required.

Several authors (Bollen 1989:226-232; Pedhazur & Schmelkin 1991:631; Joreskog & Sorbom 1989:96) discuss some of the problems of EFA and their limits. The problems discussed by these authors reflect the inability of EFA to accommodate theoretical knowledge. CFA overcomes these shortcomings, but the strengths of CFA can only be exploited once the model is expertly formulated. Once the model is constructed, it can be estimated, and its fit to the data can be assessed. It is evident then, that CFA provides a much more powerful tool in confirmatory research than EFA.

In practice the distinction between EFA and CFA is more blurred than the foregoing discussion suggests. For example, researchers using EFA procedures may restrict their analysis to a group of indicators that

they believe are influenced by one factor. By doing so, they test an implicit if not explicit model. On the other hand, researchers with poorly fitting models in a CFA often modify their model in an exploratory way with the goal of improving fit. Thus the distinction made between EFA and CFA should be seen as ideal types with most applications falling between the two extremes.

As mentioned in chapter four, structural modelling is made up of two components, the measurement model and the structural model. The measurement model relates the observed variables to the latent factors. This component of structural modelling is therefore identical to confirmatory factor analysis.

### **5.4.1.3 TESTING OF HYPOTHESES**

In chapter four, several hypotheses were formulated and then combined to form a structural equation model (see figure 4.7 or figure 5.1). The structural model specifies the relations of the constructs to one another, as posited by theory. The structural model was then tested (estimated) against data obtained from secondary school children. The hypothesized structural model was estimated by LISREL 7 (Joreskog & Sorbom 1989). A major strength of LISREL is its latent-variables approach to model testing, whereby multiple indicators improve construct validity of measurements and reduce measurement errors (Reynolds & Walberg 1991).

In addition, a planned procedure to test several alternative models was employed. Because of the complexities of structural-equation modelling and the numerous ways of specifying models, a systematic approach is recommended. Following a planned procedure not only makes data analysis more manageable but also helps avoid misspecification and enables other researchers to replicate results. In this study, Anderson and Gerbing's (1988) two-step approach was used. In this approach, the measurement model and structural models are estimated separately.

### **5.4.2 COMPLETION AND TREATMENT OF DATA**

The questionnaires were administered in the second and third weeks of October, 1998, just before students sat for their final examinations. Tables 5.1 and 5.2 give a summary of the number of students who responded correctly to the questionnaire.

The examination mark for physical science/general science was then written onto each usable questionnaire. The data from the questionnaires were then read onto a magnetic disc which was then used to process the data. Use was made of the Statistical Package for Social Sciences (SPSS) and LISREL programmes for carrying out the statistical analyses.

## **5.5 RESULTS**

The results and interpretation of the empirical study are provided in the sections that follows.

### **5.5.1 DESCRIPTIVE STATISTICS**

Raw scores were used in the analyses. An examination of the distributions of all variables as well as bivariate plots indicated that variables deviated slightly from normality and a number of outliers were present. These abnormalities could impact negatively on the results of the statistical analyses employed. Although the estimation methods used in LISREL are robust against small deviations from multivariate normality (Cuttance & Ecob 1987, chapter 9), the effect of outliers is unpredictable. Unfortunately, there are no clear-cut procedures (to my knowledge) on the treatment of outliers. The tendency of simply deleting cases of outliers is also not recommended (Pedhazur & Schmelkin 1991:398-408). All usable cases were therefore used in the analyses that follow.

Descriptive statistics for the variables used in the study, including means, standard deviations and reliabilities (coefficient alpha) are presented in table 5.6. The reliabilities were satisfactory, except that of instructional time. The latter was therefore dropped from further analyses. The moderate reliabilities of attitude towards practical work (PWA) and the usefulness of science attitude (UA) are possibly due to the low number of items (three and four respectively). As such they are retained for subsequent analyses.

Correlations between all pairs of variables are presented in table 5.7. The majority of correlations were moderate in magnitude and statistically significant. Thus, considerable common variance existed for the confirmatory factor analyses.

### **5.5.2 PRELIMINARY TESTS OF MEASUREMENT MODELS**

Before testing the structural model, preliminary confirmatory factor analyses were carried out for each of the proposed factors to determine the adequacy with which they were represented by the variables administered. This strategy allows an evaluation of the statistical significance and goodness of fit of measurement models for each proposed factor, as opposed to assessing only a global measurement model. For these and subsequent structural analyses, the data that actually were modelled were variances and covariances, as opposed to the correlations presented in table 5.7. The latter were presented to facilitate the reader's interpretation. Covariances are cumbersome to interpret.

Table 5.6 Descriptive statistics of observable variables

<b>FACTORS AND OBSERVED VARIABLES</b>	<b>MINI MUM</b>	<b>MAXI MUM</b>	<b>MEAN</b>	<b>SD</b>	<b>RELIA BILITY</b>	<b>No. ITEMS</b>
<b>HOME</b>						
Parental Attitudes (PA)	4	16	13.13	2.13	0.79	9
Parental Involvement (PI)	18	60	42.23	7.90	0.80	15
Socioeconomic status (SES)	7	41	21.83	6.59	0.60	10
<b>SCHOOL</b>						
Teacher Characteristics (TC)	10	56	40.03	7.14	0.77	14
Instructional Time (IT)	2	13	9.22	1.84	0.21	3
School Environment (SE)	7	36	23.52	5.37	0.69	9
<b>PERSONAL</b>						
Motivation (MOT)	27	59	45.13	5.49	0.61	15
Science Self-concept (SC)	20	60	43.01	6.92	0.76	15
<b>ATTITUDE</b>						
General Attitude (GA)	14	56	42.98	7.07	0.79	14
Usefulness Attitude (UA)	3	16	12.75	2.34	0.46	4
Career/Courses Attitude (ACC)	2	8	6.34	1.69	0.61	2
Practical Work Attitude (PWA)	1	12	9.25	1.86	0.35	3
<b>ABILITY</b>					0.68	4
Science Mark (PSA)	1	99	44.40	19.53	-	1
Math Mark (MA)	1	98	37.67	20.78	-	1
English Mark (EA)	4	99	53.96	21.21	-	1
Number of Failures (NF)	1	5	4.48	0.72	-	1
<b>ACHIEVEMENT (ACHIE)</b>	8	98	36.74	12.80	-	1

**Table 5.7** Correlations among observed variables

	A	B	C	D	E	F	G	H	I	J	K	L	M	N	O	P
A	1.0															
B	-	1.0														
C	-	18	1.0													
D	62	17	12	1.0												
E	12	17	47	18	1.0											
F	45	23	14	57	16	1.0										
G	-	17	-	-	-	09	1.0									
H	32	-	-	30	11	32	-	1.0								
I	16	-	-	23	11	28	11	38	1.0							
J	13	30	59	21	51	21	-	-	-	1.0						
K	40	13	13	38	22	40	-	20	13	17	1.0					
L	48	28	10	66	15	60	-	32	30	26	39	1.0				
M	-	-	-	-	-	12	-	-	15	-	08	-	1.0			
N	-	-	14	14	16	12	09	24	28	12	-	15	14	1.0		
O	16	-	-	28	-	25	-	25	46	-	16	33	24	18	1.0	
P	54	-	09	50	-	41	-	32	25	-	36	40	-	-	20	1.0

The values in the table are in hundredths and the comma is not included. Non significant correlations ( $p>0.05$ ) are represented by -. A=Career/Courses Attitude; B=Achievement; C=English Mark; D=General Attitude; E=Math Mark; F=Motivation; G=Number of Failures; H=Parental Attitudes; I=Parental Involvement; J=Physical Science Mark; K=Practical Work Attitude; L=Self-concept; M=School Environment; N=Socioeconomic Status; O=Teacher Characteristics; P=Usefulness Attitude.

To use all relevant information in determining the best model, assessment of the fit of the models was based on descriptive, comparative, and substantive criteria. Multiple fit criteria are recommended in the structural equation modelling literature. In this study, the following criteria were used:

- the sign and magnitude of the structural coefficients;
- small values of chi-square relative to degrees of freedom. That is, the ratio of chi-square to degrees of freedom;
- large probability values ( $p>0.05$ ) associated with model chi-square; and



- (d) LISREL's fit indices, including the goodness-of-fit index (GFI) and the adjusted goodness-of-fit index (AGFI).

The root mean square residual (RMR) is difficult to interpret when unstandardised variables are analysed. It is interpretable when all observable variables are completely standardised in which case small values indicate better fit. The reason small values of chi-square and large probabilities are desirable is that the probability associated with chi-square in the present context can be conceptualized as the probability of obtaining the observed data if the proposed model is true for the population. Because the chi-square statistic is biased upward with large samples, a chi-square ratio between two and three is often recommended (Reynolds and Walberg, 1991). The goodness-of-fit indices range from zero to one, with higher values indicating better fit. The usual cut-off value for these indices is 0.9.

Results from the preliminary confirmatory factor analyses for each factor (except achievement) are presented in figures 5.2 to 5.8. Starting with the Home factor (figure 5.2), an excellent model fit was found<sup>1</sup>. The chi-square value to degrees of freedom ratio was acceptable (2.91); the probability was greater than 0.05; both the GFI and AGFI were greater than 0.9; all factor loadings had the expected positive sign, were significant ( $t > 2$ ) and relatively large.

---

<sup>1</sup>When using confirmatory factor analysis with three observed variables, it is necessary to impose an additional constraint on the model to obtain the degree of freedom required for the chi-square test. Under these circumstances, the best parameter estimates are obtained when the constraint that is best supported by the data is imposed. For the Home factor, the loading of PA was set to unity. Although this procedure capitalizes on chance to some degree, it was neither required by nor imposed in the subsequent tests of the full models because of the degrees of freedom afforded by the variables in those models.

**Figure 5.2 Measurement Model of the HOME FACTOR**

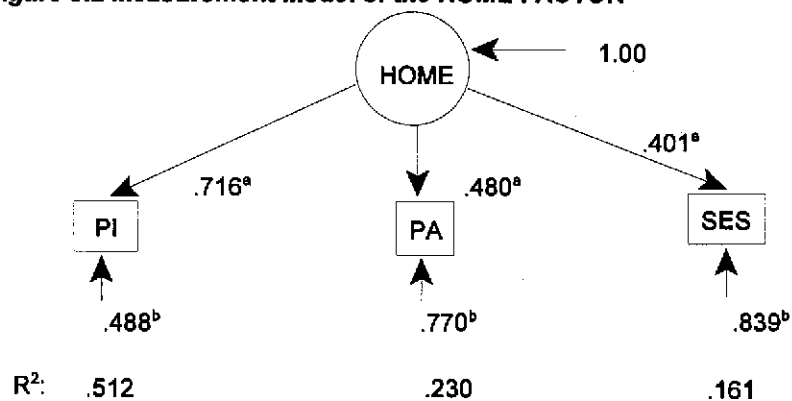

$\chi^2$  (1df, N=535) = 2.91 ; p=0.088 ; GFI=0.996 ; AGFI=0.979 ; RMR=0.582

PI=Parental Involvement; PA=Parental Attitudes; SES=Socio-Economic Status; R<sup>2</sup> is the coefficient of determination and represents the lower bound reliability coefficient of the observed variable; GFI=Goodness-of-Fit Index; AGFI=Adjusted Goodness-of-Fit Index; RMR=Root Mean square Residual; <sup>a</sup>=factor loadings; <sup>b</sup>=measurement error in the observed variable

As shown in figure 5.3 and 5.4, similar acceptable fits were found for the measurement models of ABILITY and ATTITUDE.

Figure 5.3 Measurement model of the ABILITY FACTOR

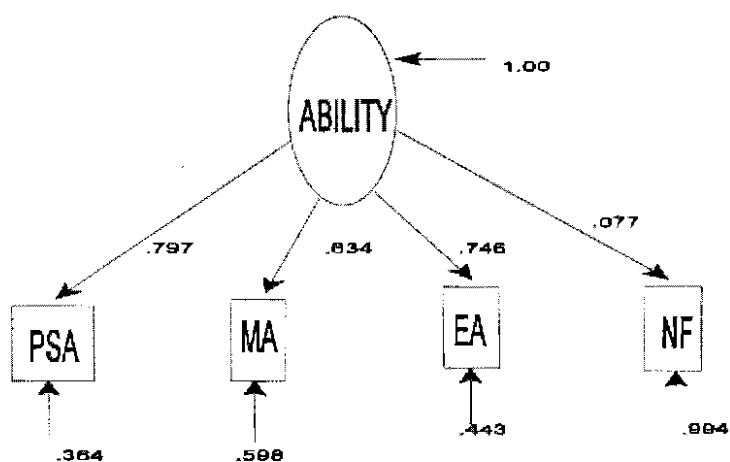

R <sup>2</sup> :	.636	.402	.557	.006
------------------	------	------	------	------

$\chi^2 = 1.13$ ;  $df = 2$ ;  $p = 0.567$ ;  $GFI = 0.999$ ;  $AGFI = 0.995$ ;  $RMR = 0.296$

PSA=Physical Science Ability; MA=Math Ability; EA=English Ability; NF=Number of Failures

**Figure 5.4 Measurement Model of the ATTITUDE FACTOR**

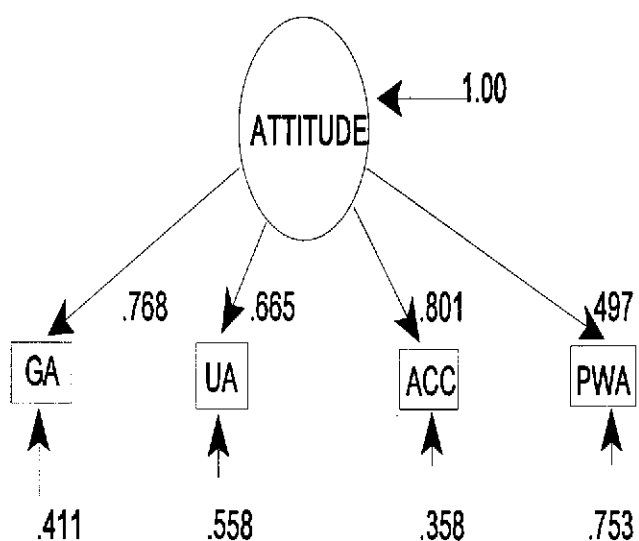

R <sup>2</sup> :	.589	.442	.643	.247
------------------	------	------	------	------

$\chi^2 = 1.28$ ;  $df = 2$ ;  $p = 0.527$ ;  $GFI = 0.999$ ;  $AGFI = 0.994$ ;  $RMR = 0.056$

GA=General Attitude; UA=Usefulness Attitude; ACC=Attitude towards Courses & Careers; PWA=Practical Work Attitude.

The SCHOOL and PERSONAL measurement models had to be respecified because both had only two observed variables and hence were unidentified. Consequently, MOTIVATION and Self-concept were measured separately, instead of both being used to measure the PERSONAL latent factor. An analysis of how the items were constructed revealed that motivation actually constitutes four observed variables, namely intrinsic motivation, persistence, achievement motivation and some residual motivation. When so constructed, the measurement model of motivation yielded acceptable fit (see figure 5.5).

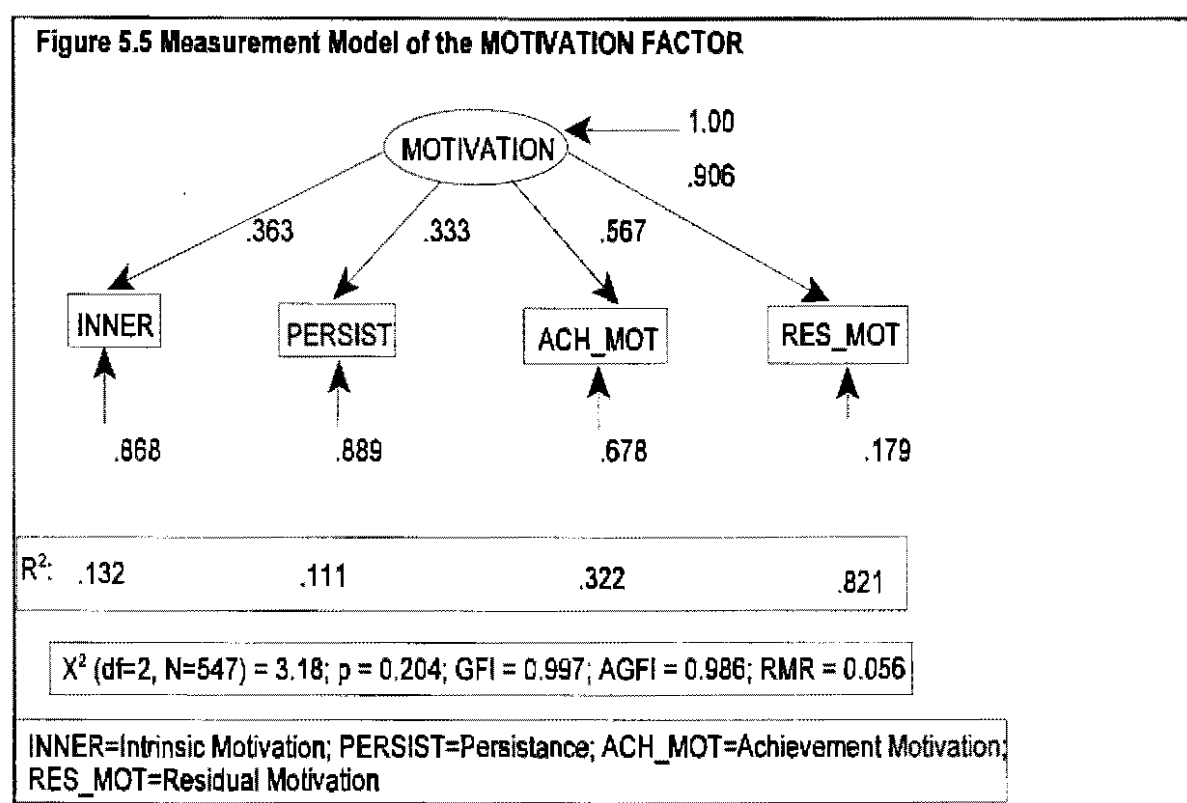

Similarly, self-concept was respecified using three observable variables, namely academic science self-concept and two split-half variables (one with seven items and the other with 6 items). The resultant model gave acceptable fit (see figure 5.6).

**Figure 5.6 Measurement Model of the SELF CONCEPT FACTOR**

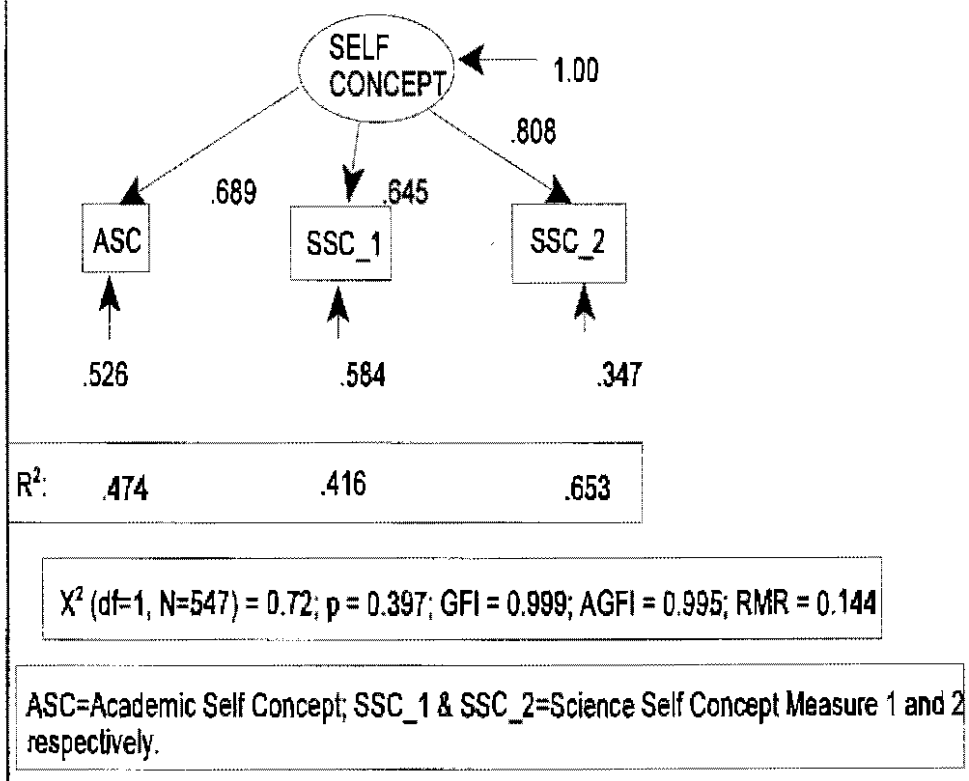

Finally, the SCHOOL latent factor was also respecified after instructional time was found to be low in reliability (section 5.5.1). Exploratory analyses (see appendix B) indicated that two constructs are measured by the school variables, namely teacher characteristics and school environment. Both of these factors gave acceptable fits (see figures 5.7 and 5.8).

**Figure 5.7 Measurement Model of the TEACHER CHARACTERISTICS FACTOR**

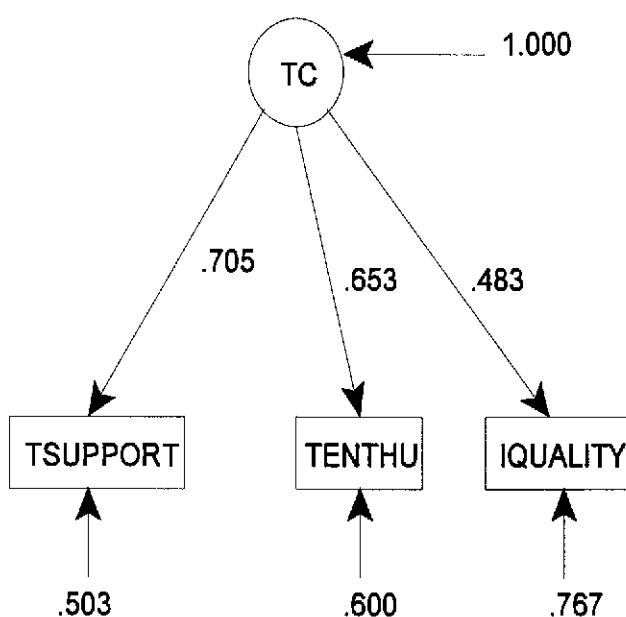

R <sup>2</sup> :	.497	.400	.233
------------------	------	------	------

$X^2 (1df, 546) = 3.40; p = 0.065; GFI = 0.996; AGFI = 0.975; RMR = 0.303$

The variables are Teacher support, Teacher Enthusiasm and Instructional Quality, respectively.

**Figure 5.8 Measurement Model of the SCHOOL ENVIRONMENT FACTOR**

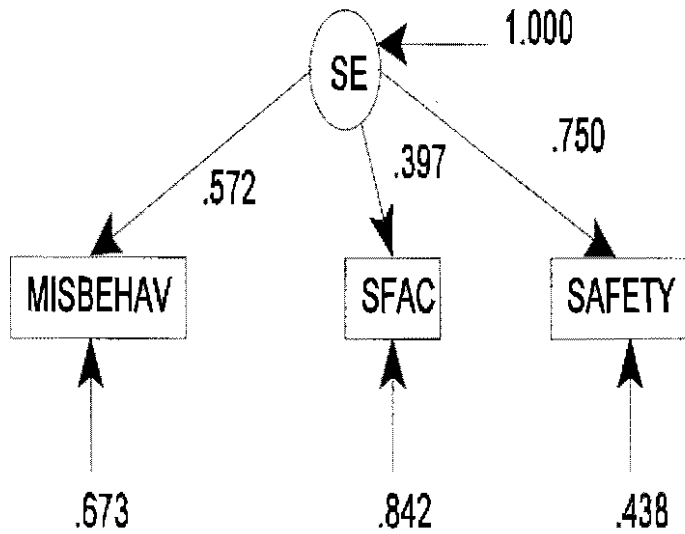

R <sup>2</sup> :	.327	.158	.562
------------------	------	------	------

$\chi^2 (1df, 547) = 0.20; p = 0.656; GFI = 1.00; AGFI = 0.999; RMR = 0.065$

The variables are Misbehaviour, School Facilities and Safety at school, respectively.



Further analysis of figures 5.2 to 5.8 indicates that School Facilities (coefficient of determination ( $R^2$ ) = 0.158), Socio-Economic Status ( $R^2$  = 0.161), Intrinsic Motivation ( $R^2$  = 0.132), Persistence ( $R^2$  = 0.111) and Number of Failures ( $R^2$  = 0.006) should be dropped from subsequent analyses. These variables have low reliabilities when acting as observable variables for their respective factors (Bong, 1997).

The remaining variables in all the factors, including the physical science achievement measure, were used in estimating the global measurement model.

### 5.5.3 ESTIMATION OF THE GLOBAL MEASUREMENT MODEL

The measurement models of the individual factors were combined to estimate the global (full) measurement model. The results are given in table 5.8.

As shown in table 5.8, each latent factor has more than one observable variable (except achievement). The factor loadings indicate the extent to which the observed variables index their respective latent factors. The latter are hypothesised common causes of the non-error variation in the observed variables. Significant factor loadings indicate confirmation of this relationship, supporting the construct validity of the latent variables. As seen in table 5.8, all observed variables load significantly on their underlying factors ( $t$ -values  $> 2$ )<sup>2</sup>.

Internal-consistency reliability estimates of the observed variables were also computed. These estimates are given as standard output in LISREL. These reliability estimates, however, are lower bounds of the true reliabilities. As shown in table 5.8, the reliabilities varied considerably. The variation in reliabilities, as well as the factor loadings, suggest differential precision in measurement, which is taken into account in estimation of the structural effects. For example, the attitude towards practical work (PWA) was measured less well than other variables.

The global measurement model fit the data fairly well ( $\chi^2/df$  = 2.93; GFI = 0.924; AGFI = 0.9). The model was substantively interpretable, as the factor loadings were of the expected sign and were all significant.

---

<sup>2</sup>

T-values are used in LISREL to examine whether the true parameter is zero. T-values greater than two are normally judged to be significantly different from zero (Joreskog & Sorbom, 1989:89-90).

**Table 5.8** Confirmatory factor analysis for measurement model evaluation: model fits and loadings for the completely standardised solution

FACTOR	VARIABLE	LOADING <sup>a</sup>	RELIABILITY <sup>b</sup>
Self-concept	ASC	0.758	0.574
	SSC_1	0.717	0.514
	SSC_2	0.708	0.501
MOTIVATION	ACH_MOT	0.509	0.371
	RES_MOT	0.839	0.703
ABILITY	PSA	0.835	0.696
	MA	0.624	0.390
	EA	0.715	0.512
ATTITUDE	GA	0.836	0.698
	UA	0.609	0.371
	ACC	0.739	0.546
	PWA	0.490	0.240
ACHIEVEMENT	ACHIE	0.949	0.900 <sup>c</sup>
HOME	PA	0.591	0.349
	PI	0.666	0.443
TEACHER CHARACTERISTICS	IQUALITY	0.553	0.305
	TENTHU	0.626	0.392
	TSUPPORT	0.690	0.477
SCHOOL ENVIRONMENT	SAFETY	0.740	0.548
	MISBEHAV	0.578	0.334
$\chi^2$ (145 df) = 424.21 $\chi^2/df$ = 2.93    GFI = 0.924    AGFI = 0.889 ≈ 0.9			
<sup>a</sup> All loadings are significant at $p < 0.001$			
<sup>b</sup> Estimated in LISREL as lower-bound reliability (Joreskog & Sorbom, 1989:79)			
<sup>c</sup> The error variance was set at $0.1s^2$ . This was preferable rather than assuming perfect measurement for the single observed variable of achievement.			

One outcome of the measurement model is a correlation matrix of latent variables, which serves as the basis for estimating structural models. This matrix is shown in table 5.9. The correlations are moderate, suggesting that they tap somewhat independent dimensions. According to Bong (1997), a correlation coefficient greater than 0.9 between two factors raises a question of discriminant validity. That is, two factors with a correlation of 0.9 and greater actually measure one construct and thus need to be combined. Combining such highly correlated factors enhance parsimony of the model since simpler models facilitate easier interpretation.

**Table 5.9 Correlations between the latent factors**

	SC	MOT	ABILITY	ATT	ACHIEVE	HOME	TC	SE
SC	1.000							
MOT	.730	1.000						
ABILITY	.278	.256	1.000					
ATT	.826	.689	.254	1.000				
ACHIEVE	.372	.297	.333	.233	1.000			
HOME	.578	.475	.140	.533	-	1.000		
TC	.447	.348	-	.346	-	.696	1.000	
SE	-	-	-	-	-	.153	.169	1.000

SC=Self-concept; MOT= Motivation; ATT=Attitude; TC=Teacher Characteristics; SE=School Environment. All values are statistically significant. Non significant values are represented by -.

The affective factors were among the highest correlations. Self-concept correlated highly with motivation ( $r=0.730$ ), attitude ( $r=0.826$ ) and the affective component of the home ( $r=0.578$ ). Remember that the home factor was measured by parental attitudes and involvement in the schooling process. Similarly, motivation correlated highly with attitude ( $r=0.689$ ) and moderately with home factors ( $r=0.475$ ). Attitude correlated moderately with the home factors ( $r=0.533$ ).

Surprisingly, achievement correlated moderately with the affective factors and ability whereas the correlations with home and school factors were non significant.

#### 5.5.4 ESTIMATION OF THE STRUCTURAL MODEL

The structural equation model which specifies the relationships between the latent factors (see figure 5.9) was estimated. In section 5.5.3, the measurement model showed how the observed variables are related to their underlying latent factors. In this and following sections, the emphasis is on the relationship between the latent factors. It should be noted that in each estimation of the structural model, the observed variables in the previous section were used. This is the advantage of following a planned systematic procedure in model building and testing.

Analysis of the hypothesised or theoretical model ( $M_1$ ) yielded a reasonably good-fitting model by multiple criteria ( $\chi^2/df=3.63$ ; GFI=0.905; AGFI=0.869). The structural coefficients (parameters) of the theoretical model are given in table 5.10.

**Figure 5.9 Theoretical Structural Model (M<sub>t</sub>)**

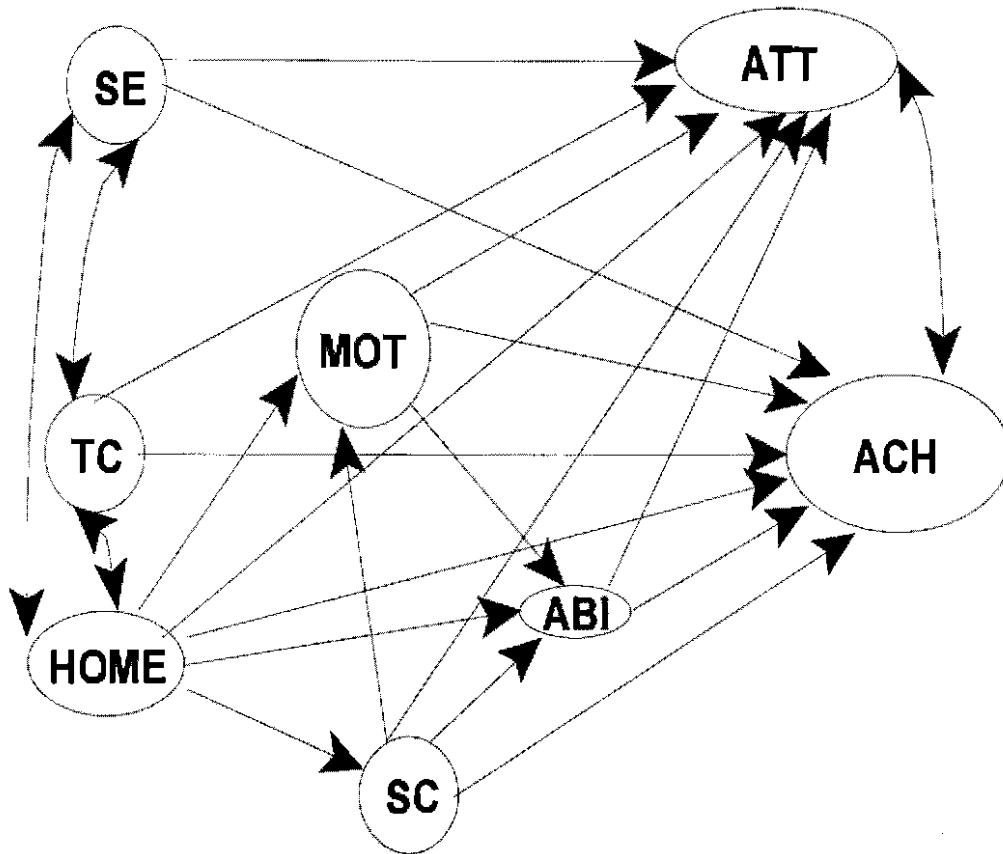

**TC=Teacher Characteristics; SE=School Environment;  
 SC=Self Concept; MOT=Motivation; ABI=Ability;  
 ATT=Attitude; ACH=Achievement.**

**Table 5.10 Values of Standardised Parameter Estimates and Test Statistics (t) for the theoretical model**

PATH	VALUE	t
Home – Self-concept	0.565	6.891
Home – Motivation	0.080	1.067
Home – Ability	-0.046	-0.554
Home – Attitude	0.126	1.968
Home – Achievement	-0.250	-3.101
Teacher Characteristics – Attitude	-0.010	-0.234
Teacher Characteristics – Achievement	-0.055	-1.072
School Environment – Attitude	0.052	1.007
School Environment – Achievement	0.056	0.928
Self-concept – Motivation	0.679	8.937
Self-concept – Ability	0.223	2.020
Self-concept – Attitude	0.631	6.743
Self-concept – Achievement	0.424	4.060
Motivation – Ability	0.115	1.163
Motivation – Attitude	0.164	2.133
Motivation – Achievement	0.053	0.591
Ability – Attitude	0.020	0.468
Ability – Achievement	0.236	4.506

Inspection of the structural coefficients, however, revealed that some hypothesised relations were of an opposite sign, suggesting that another model might result in a better-fitting and more parsimonious model. Consequently, paths with negative parameters and those with non-significant parameters ( $t < 2$ ) were deleted from the model and the resulting constrained model ( $M_c$ ) was estimated.

The constrained model (figure 5.10) effectively omits the two school factors (teacher characteristics and school environment). The constrained model, however, is more parsimonious than the theoretical model and has a slightly better fit ( $\chi^2/df=3.23$ ; GFI=0.935; AGFI=0.906).

Figure 5.10 Constrained Structural Model (M<sub>2</sub>)

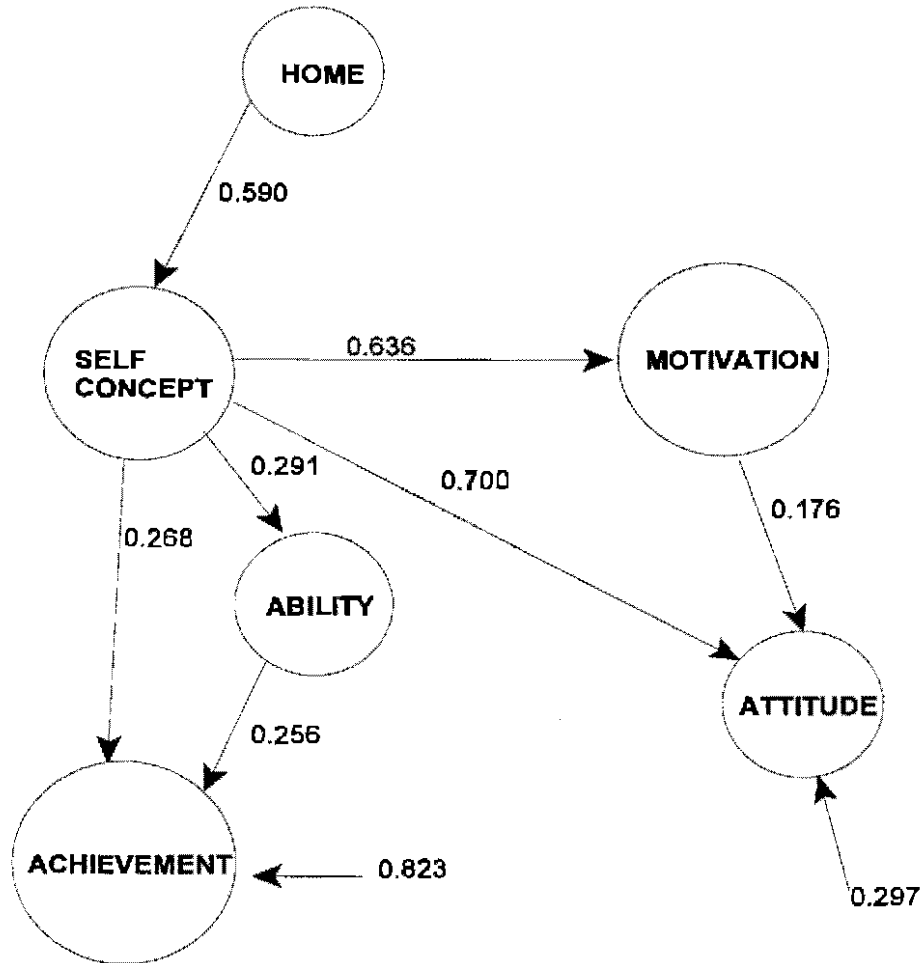

All parameters are statistically significant ( $t > 2$ ).

The last step in the Anderson and Gerbing's (1988) approach is the estimation of an unconstrained model ( $M_U$ ). In the unconstrained model, one or more parameters which were fixed in the theoretical model are freed. The freed parameters must be of substantive value. Consequently, the following paths were freed (using both substantive criteria and the modification index of LISREL):

- (a) Home – School Environment;
- (b) Teacher Characteristics – School Environment;
- (c) Teacher Characteristics – Ability;
- (d) School Environment – Self-concept;
- (e) School Environment – Motivation; and
- (f) Attitude – Achievement.

The unconstrained model (table 5.11) did not yield better fit than the theoretical and constrained models ( $\chi^2/df=3.63$ ; GFI=0.907; AGFI=0.869). Note that when negative and non-significant parameters are eliminated from the unconstrained model, a model similar to the constrained model is found. It can therefore be concluded that the best fitting model for the data set at hand is the constrained model ( $M_U$ ).

## 5.5.5 EFFECTS ON PHYSICAL SCIENCE ACHIEVEMENT

### 5.5.5.1 DIRECT EFFECTS

Four factors were posited to have direct effects on physical science achievement, namely home, school, personal and ability variables. During the construction of the measurement model, the school factor was separated into teacher characteristics and school environment whereas the personal factor was separated into self-concept and motivation. As such four paths led to achievement from the school and personal factors instead of two.

Of the six posited direct effects on physical science achievement, five had the hypothesised signs, and ability and self-concept were statistically significant (see table 5.10). The latter had moderate effects on physical science achievement.

The home environment was not in the expected direction, implying that students who did well in physical science under reported the contribution of parents, or alternatively, students who performed poorly in physical science over reported the contribution of parents.

**Table 5.11 Values of Standardised Parameter Estimates and Test Statistics (t) for the unconstrained model**

<b>PATH</b>	<b>VALUE</b>	<b>t</b>
Home – Self-concept	0.569	6.918
Home – Motivation	0.073	0.964
Home – Ability	-0.014	-0.166
Home – Attitude	0.119	1.850
Home – Achievement	-0.230	-2.775
Home – School Environment	0.029	0.410
Teacher Characteristics – Attitude	-0.009	-0.204
Teacher Characteristics – Achievement	-0.053	-0.975
Teacher Characteristics – School Environment	0.171	2.464
Teacher Characteristics – Ability	-0.102	-1.749
School Environment – Attitude	0.060	1.278
School Environment – Achievement	0.075	1.272
School Environment – Self-concept	-0.031	-0.526
School Environment – Motivation	0.080	1.481
Self-concept – Ability	0.231	2.093
Self-concept – Attitude	0.639	6.655
Self-concept – Achievement	0.580	3.826
Self-concept – Motivation	0.689	8.936
Motivation – Ability	0.115	1.159
Motivation – Attitude	0.160	2.027
Motivation – Achievement	0.085	0.902
Ability – Attitude	0.015	0.341
Ability – Achievement	0.239	4.424
Attitude – Achievement	-0.232	-1.820

School environment, teacher characteristics, and motivation had negligible effects on physical science achievement. In the case of the school factors, what goes on in school may not comprehensively represent the quality of instruction in the middle school years. This is possibly due to the absence of a culture of teaching and learning in most urban black schools. There is no apparent reason why motivation had such a negligible effect on physical science achievement.



Although the effect of ability was expected to be large and positive, the significant direct influence of self-concept on physical science achievement support the importance of affective factors in science achievement.

#### 5.5.5.2 INDIRECT AND TOTAL EFFECTS

To measure the indirect and total effects on physical science achievement, use was made of the constrained model because it was the best fitting model. The direct, indirect and total effects drawn from the constrained model are given in table 5.12. The home and self-concept had indirect effects on physical science achievement. The former had the largest indirect effect on achievement, mainly through its effect on self-concept, but also through ability. This result is different from those reported by Reynolds and Walberg (1991, 1992). In these studies, the home had the largest indirect effect mainly through its effect on prior achievement (that is, ability).

As in the case of the studies by Reynolds and Walberg, the home environment's main contribution is in improving cognitive readiness (ability) and as found in this study, affective readiness, which then influences final physical science achievement rather than influencing achievement directly.

The total effects in table 5.12 indicate the aggregate contribution of psychological and social factors on physical science achievement. Of the initially four posited factors, only the school factor did not make a significant contribution to physical science achievement. The home, self-concept (personal) and ability contributed to achievement in physical science.

**Table 5.12 Direct, indirect and total effects on physical science achievement**

FACTOR	DIRECT EFFECT	INDIRECT EFFECT	TOTAL EFFECT
HOME	-	1.670 (5.03)	1.670 (5.03)
Self-concept	1.570 (5.22)	0.438 (3.78)	2.008 (6.78)
MOTIVATION	-	-	-
ABILITY	0.189 (4.90)	-	0.189 (4.90)
ATTITUDE	-	-	-
T values are in parenthesis. $T > 2$ means the parameter is significant ( $p < 0.05$ )			

#### 5.5.6 EFFECTS ON PHYSICAL SCIENCE ATTITUDE

Of the six posited direct effects on physical science attitude, five had the hypothesised signs, and motivation and self-concept were statistically significant (see table 5.10). Motivation had a moderate

effect on physical science attitude whereas self-concept had a substantially high effect on physical science attitude.

The teacher characteristics factor was not in the expected direction, implying that students with positive attitudes toward physical science under report the role of teachers, or alternatively, students with negative attitudes toward physical science overestimate the role of teachers.

Home environment and ability had negligible direct effects on physical science attitude. The home factor, however, had a significant indirect effect on physical science attitude (see table 5.13), mainly through the self-concept. This represents the transmission of parental influence on attitude development, even in the middle school years.

Contrary to previous research (Reynolds & Walberg, 1992), ability had neither a direct nor an indirect effect on physical science attitude. Since the correlation between ability and attitude is moderate ( $r=0.254$ ), the absence of a significant effect of ability on attitude implies that the correlation between the two factors is zero when other factors are controlled.

The results in table 5.13 indicate that affective variables (home and personal) are highly related to physical science attitudes. Furthermore, these variables account for a substantial variance accounted for in physical science attitude (70.3%). The constrained model therefore accounts for physical science attitude far better than for physical science achievement. Only 17.7% of the variance in physical science achievement is accounted for by factors in the constrained model.

**Table 5.13 Direct, indirect and total effects on physical science attitude**

FACTOR	DIRECT EFFECT	INDIRECT EFFECT	TOTAL EFFECT
HOME	-	0.415 (6.59)	0.415 (6.59)
Self-concept	0.412 (7.77)	0.071 (2.22)	0.483 (12.38)
MOTIVATION	0.102 (2.17)	-	0.102 (2.17)
ABILITY	-	-	-
ACHIEVEMENT	-	-	-

**T values are in parenthesis. T>2 means the parameter is significant (p < 0.05)**

### 5.5.7 EFFECTS OF GENDER ON PHYSICAL SCIENCE ACHIEVEMENT AND ATTITUDE

Gender differences in physical science achievement and attitude were reported in some studies in the literature study. To test the hypothesis that girls and boys differ in achievement and attitude towards

physical science, the best fitting model was re-estimated using the multiple-group analysis option of LISREL. In this case the groups were a sample of boys (N=250) and a sample of girls (N=273).

To ascertain that apples are not compared with oranges (Wagner, Torgesen, Laughon, Simmons & Rashotte, 1993), the factor loadings were constrained to be equal across the groups to facilitate comparison<sup>3</sup>.

To test the hypothesis of gender differences, the fit of the model with no constraint in the distribution of the latent factors across the groups ( $\chi^2$  (175df) = 406.84; GFI = 0.908) was compared with the fit of the model where the distribution of the latent factors was invariant across the groups ( $\chi^2$  (183df) = 412.01; GFI = 0.907). The difference in  $\chi^2$  in the two models equals 5.17 with eight degrees of freedom, which is not statistically significant ( $p > 0.05$ ). As such, it can be concluded that the boys and girls of this study do not differ in their achievement and attitude towards physical science.

## 5.6 REMARKS

The design of the empirical investigation was done in this chapter. The objectives of the study, as well as the statistical methods that were used to meet these objectives were described.

It was also decided to make use of the questionnaire for gathering information from respondents. The rationale behind this choice as well as mechanisms followed in the preparation of the questionnaire were also given.

Finally, the procedure used in the empirical investigation, the results and interpretation of the results were outlined.

The conclusions drawn from the results, recommendations, implications and limitations of the study are discussed in chapter 6.

---

<sup>3</sup>

To build some confidence in this approach (constraining factor loadings across the groups), the fit of the model with no constraints in factor loadings was compared with one in which the factor loadings were constrained. The two models were not significantly different ( $\chi^2$  (9df) = 14.82;  $p > 0.05$ ).

## CHAPTER 6

### FINDINGS, RECOMMENDATIONS AND CONCLUDING REMARKS

#### 6.1 INTRODUCTION

The basic aim of this research was to investigate the mutual influence of psychological and social factors on science achievement and attitude among urban black South African students. The investigation purported to establish not only the interrelationships amongst the psychological and social factors on science achievement and attitude, but the structural relations existing among these factors. Three reasons necessitated this approach:

- (1) Previous studies have identified a number of factors related to science outcomes through exploratory research. These factors are numerous and would complicate the regression analysis (Pedhazur & Schmelkin 1991:418-420).
- (2) Some factors, especially at junior secondary school level, do not have a direct, immediate effect but are important indirect determinants of science achievement and attitude.
- (3) By using structural relations, theories of science achievement and attitude are amenable to rigorous evaluation.

The use of structural relations, however, required a theory that specifies the relationships among the factors. To this end, a literature review was undertaken (chapters three and four). Since a number of studies in this field were undertaken outside South Africa, the "realities" that occur in the country had to be investigated (chapter two). The theory that resulted from this exercise was therefore deemed "suitable" for the context in which the investigation was undertaken. The "suitability" of the theory, however, had to be evaluated and thus the empirical study was undertaken (chapter 5).

In this chapter, the main findings derived from both the literature review and the empirical research are given. This is followed by conclusions drawn from and the limitations of the investigation. Thereafter the recommendations and suggestions for future research are presented.

## **6.2 FINDINGS AND CONCLUSIONS FROM THE LITERATURE STUDY**

### **6.2.1 OBJECTIVES OF THE LITERATURE STUDY**

The objectives set out for the literature study were:

- (i) To investigate the context in which physical science education is practised in black South African schools, particularly urban schools.
- (ii) To identify and define psychological and social factors reported in previous research which have an influence on physical science achievement and attitude of secondary school students.
- (iii) Based on (ii) above, to construct a substantive theory of psychological and social factors influencing physical science achievement and attitude.

### **6.2.2 PHYSICAL SCIENCE EDUCATION IN SOUTH AFRICA**

An extensive review of the literature on physical science education in South Africa was undertaken and focussed mainly on

- (i) the value and role of science education;
- (ii) the quality of science education; and
- (iii) the crisis in science education.

#### **6.2.2.1 THE VALUE AND ROLE OF SCIENCE EDUCATION**

Science play an important role in society. The literature review indicated that a science literate person is one who can make significant contributions in societal issues such as public policy, decision making, and the like. A society with a limited number of science literate individuals is unlikely to be competitive in the high technological era we live in. As such, science literacy should be a national priority, with active and organised efforts from scientists and educators in promoting science education and a public understanding of science. Schools, and consequently school educators, are the main vehicles through which a majority of citizens (learners) are exposed to science - they either build or destroy the foundations of an interest in science.

Not only is science necessary for individual development, but technological development also rests upon scientific developments. Technological developments, on the other hand, have a capacity of

greatly enhancing a nation's economy and general quality of life. School physical science therefore plays an important role to the individual, to the society and to the economy of the country.

### **6.2.2.2 THE QUALITY OF SCIENCE EDUCATION**

The quality of science education in schools was shown to impact profoundly on the participation and success rates in physical science. An analysis of the quality of science education in black schools revealed the following deficiencies:

- (i) inflexible work programmes resulting in less physical science taught in lower standards;
- (ii) low enrolment of females as compared to males in physical science, even though females outnumber males in secondary schools;
- (iii) language related problems;
- (iv) curricula content that do not enhance science literacy; and
- (v) lack of investigative approaches in instruction, coupled with the absence of applied science, technology, social and ethical aspects in the science curriculum.

### **6.2.2.3 THE CRISIS IN SCIENCE EDUCATION**

Section 2.4 highlighted the crisis that exist(ed) in black science education. Among others, the following problems were found:

- (i) lack of coordination between preservice and inservice training of teachers;
- (ii) lack of human resources (qualified and competent physical science teachers);
- (iii) lack of support for physical science teachers;
- (iv) overcrowding in physical science classes;
- (v) lack of academic and administrative leadership in schools; and
- (vi) poor provision for black education in general.

Compounding the above problems, barriers to participation by blacks in sciences were numerous, for example:

- (i) stringent criteria in the selection to science courses by institutions of higher learning;
- (ii) assessment criteria that increased anxiety among students and consequently affecting their performance; and
- (iii) employment discrepancies that left black students with few role models to identify with, thus hampering career aspirations in sciences.

### **6.2.3 DETERMINANTS OF SCIENCE ACHIEVEMENT AND ATTITUDE: THEORETICAL APPROACH**

The theoretical approach entailed the study of simple correlations, partial correlations, exploratory factor analyses, analyses of variance, and the like. A large number of factors related to physical science achievement and attitude were found in the literature. The factors reported in chapter three were delimited to psychological and social factors.

#### **6.2.3.1 PSYCHOLOGICAL FACTORS RELATED TO SCIENCE ACHIEVEMENT AND ATTITUDE**

##### **(a) THE STUDENT'S ABILITY**

The literature review indicated that ability is a theoretical construct pertaining to aspects such as intelligence, aptitude, thought processes, and so forth. A number of studies, including meta-analyses, demonstrated that ability is highly related to science achievement. Ability therefore play an important role in the achievement of students. As far as attitude towards science is concerned, inconsistent and very low correlation coefficients were found.

##### **(b) THE STUDENT'S GENDER**

Small but significant gender differences were found in the literature review for both science achievement and attitude. Boys were reported to demonstrate higher achievement and positive attitudes compared to girls. Furthermore, physics was particularly found to be the filtering variable in science achievement and attitude.

##### **(c) SELF-CONCEPT**

The literature review indicated that self-concept posses academic and non academic components. The former is domain specific, implying that physical science achievement correlates substantially with physical science self-concept and, for example, less with English self-concept. The influence of science self-concept on achievement and attitude was found to be significant even after the influence of ability has been controlled. Also, self-concept was found to have important effects on the motivation of students.

##### **(d) MOTIVATION**

The nature and possible mechanisms through which motivation functions in relation to students' science achievement and attitude was described in section 3.3.5. It was further shown in section

3.3.5 that academic achievement and achievement motivation were important predictors of achievement in science courses.

**(e) ATTITUDE TOWARDS SCIENCE**

From the literature review, studies that investigated the relationship between science attitude and science achievement reported correlation coefficients ranging from 0.2 to 0.5 (see table 4.8). Earlier studies reported lower correlations than recent studies, probably due to poor measurement of the construct "science attitude".

**(f) SUBJECT PREFERENCE, INTENTIONS FOR FURTHER STUDY AND CAREER ASPIRATIONS**

Several studies investigated other factors that have a bearing on science achievement, namely enrollment in a choice subject, interest in science, intentions to study science further and electing a science related career. These factors were found to have a bearing on students' achievement in science, mainly through their mediating effects on motivation and attitude.

**6.2.3.2 SOCIAL FACTORS RELATED TO SCIENCE ACHIEVEMENT AND ATTITUDE**

**(a) PARENTAL SOCIOECONOMIC STATUS**

Parental socioeconomic status was found in the literature study to be related both to scholastic achievement and science achievement. In all cases, children from higher socioeconomic status homes scored higher on science achievement measures, science attitude measures, and other measures like critical thinking, logical operations, and the like. Science itself was reported to be perceived as occupying a higher status in comparison to other fields of study. Some authors, however, contend that it is the socialising effects of children from different socioeconomic status families that make a difference in science outcomes, and not socioeconomic status per se.

**(b) THE HOME ENVIRONMENT**

The home environment was reported to have a small but significant relationship with measures of science achievement. The relationship between the home environment and science attitudes, however, was found to be moderate. The home environment was conceptualised as being made up of variables like parenting styles, parental support and encouragement in the child's schooling, intellectual stimulation, and the like.



### **(c) THE SCHOOL AND SCIENCE ACHIEVEMENT**

Analysis of the South African context (chapter two) indicated that white schools made a substantial difference in the achievement of children in general, and in science achievement in particular. In chapter three (section 3.4.3.1), the difficulty of investigating school determinants on science achievement was highlighted. Of the studies that attempted an investigation into this terrain, low relationships between school environment and science achievement were reported. The difficulties experienced in using the school as a unit of analysis prompted Staver and Walberg (1986:99) to aver that it is an unhelpful exercise to use this approach.

Classroom environment, on the other hand, had a positive relationship with science achievement. The measurement of classroom environment, however, was not an easy task. There was a lack of studies (to my knowledge) that investigated the relationship between teacher characteristics and measures of science achievement. The studies found, however, reported low to moderate correlations between the initial training of teachers and subsequent student achievement. The other teacher characteristics (age, sex, experience, personality, attitudes) gave no significant relationships with science achievement.

### **(d) THE SCHOOL AND ATTITUDE TOWARDS SCIENCE**

School and school related variables, contrary to what was found in (c) above, were found to influence students' attitudes toward science. The variables found to be important predictors of science attitudes included school type, classroom environment, curriculum materials, and teachers' academic preparedness.

## **6.2.4 DETERMINANTS OF SCIENCE ACHIEVEMENT AND ATTITUDE: THE METHODOLOGICAL APPROACH**

The methodological approach entailed studies making use of complex structural equations indicating both the direct and indirect effects among variables in the particular study. This approach was particularly important for studies investigating determinants of complex constructs like achievement and attitude. A brief introduction of structural equation modelling was presented in chapter four. Thereafter studies employing Structural Equation Modelling (SEM) were reviewed with the aim of identifying important paths<sup>1</sup> (structural relationships) leading to physical science achievement and attitude. In evaluating the paths reported in SEM literature, use was made of the corresponding

---

<sup>1</sup> Not all studies consulted included the psychological and social factors identified in chapter three in their models. It became necessary then to focus on individual paths that will ultimately lead to a comprehensive model.

relationships found in the theoretical approach. As such several hypotheses were formulated (see pages 93 to 104), namely:

- (a) Home environment variables affect students' final achievement in physical science positively and directly.
- (b) Home environment variables affect personal and ability variables positively and directly. Home environment variables also affect students' final achievement indirectly through motivation and initial achievement.
- (c) Home environment variables influence attitude towards physical science directly and positively.
- (d) Personal variables influence students' attitudes toward science directly.
- (e) Personal variables influence students' science achievement directly.
- (f) School variables have a direct and positive influence on students' science achievement.
- (g) School variables influence attitude towards science directly and positively.
- (h) Ability has a direct and positive effect on attitude towards science.

These hypotheses were then combined into a structural equation model (figure 4.7) specifying the relationships among the psychological and social latent factors identified in chapter three. The model was subsequently tested using data collected from urban black secondary school students.

### **6.3 FINDINGS AND CONCLUSIONS FROM THE EMPIRICAL STUDY**

From the analysis and interpretation of data in chapter five, the following important findings and conclusions have emerged. It should be pointed out that the conclusions drawn are restricted to the junior secondary school level and the measures used as indicators of the constructs studied, as is always the case in multivariate analyses.

#### **6.3.1 THE OBJECTIVES OF THE EMPIRICAL INVESTIGATION**

The objectives set out for the empirical investigation were:

- (i) To construct a questionnaire for measuring the factors identified in the literature study and as portrayed in the theoretical structural equation model.
- (ii) To investigate the factorial structure of the instruments used in the questionnaire through confirmatory factor analysis.
- (iii) To test the theoretically developed structural equation model of science achievement and attitude using LISREL 7 methodology.

### **6.3.2 PHYSICAL SCIENCE ACHIEVEMENT AND ATTITUDE OF URBAN BLACK STUDENTS**

The results of the empirical research indicated that black adolescents used as subjects in this study had positive physical science attitudes, in spite of all the problems identified in chapter two. For example, a mean of 42.98 was found from a maximum possible score of 56 for general attitude towards physical science (table 5.6). Similar high scores were found for the other attitude categories. The positive attitude, however, did not translate to high achievement in the final examinations, with students scoring an average of 44.4%.

### **6.3.3 THE FACTORIAL STRUCTURE OF THE MEASUREMENT MODEL**

Structural equation modelling was used in this study to investigate the determinants of physical science achievement and attitude. The beauty of SEM is its ability to specify relationships among latent variables, as opposed to other methods which only provide relationships among observed variables. In addition, SEM takes into account such matters as measurement error in observed variables and multiple-indicators that improve construct validity.

Structural equation modelling is a complicated and time consuming endeavour. Its complexity can easily overwhelm a researcher and as such systematic approaches to model testing are recommended. In this study, use was made of the Anderson and Gerbing's (1988) two step approach to model testing. According to this approach, the measurement model (amounting to a confirmatory factor analysis) is tested separately (before) from the structural model. The theoretical structural model ( $M_1$ ) itself is further compared to two other plausible models; a constrained model ( $M_c$ ) and an unconstrained model ( $M_u$ ).

In addition to the Anderson and Gerbing's approach, Bong's (1997) approach of testing the factorial structure of each latent factor separately was utilized. This was particularly useful in this study because of the large number of latent factors used. For example, the formulation of the hypotheses that generated the theoretical model used motivation and self-concept as constituent components of.

the personal latent factor. Motivation and self-concept, however, are themselves multidimensional constructs with a large covariance amongst them. As such it was found necessary to separate these two constructs. Similarly, the school latent factor was separated into teacher characteristics and school environment<sup>2</sup>. Although the home factor could also be separated into three first order latent constructs, it was retained as one first order factor for the sake of parsimony and comparison with previous research.

Both the individual factors and global measurement models gave significant and large factor loadings (figures 5.2 to 5.8; table 5.8). The construct validity of the measurement model was therefore supported. Internal consistency reliability estimates of the observed variables estimated in LISREL, however, varied considerably. These estimates were calculated as lower-bound reliabilities in LISREL. The reliabilities (alpha coefficients) of the observed variables were, however, calculated with the SPSS program and were of an acceptable level, except instructional time which was, as a result, omitted in the analyses reported in chapter five.

The global measurement model also fit the data well with multiple criteria and was substantively interpretable.

#### **6.3.4 CORRELATIONS AMONGST THE LATENT FACTORS**

The measurement model produced a correlation matrix of the latent factors, a unique feature of structural equation modelling. The correlations were moderate, suggesting that independent dimensions were measured. Affective factors correlated highly with each other, as in previous research. Achievement, on the other hand, correlated moderately with affective factors. The moderate correlation of achievement with ability was contrary to previous research, in which high correlations were reported. This was caused, probably, by the use of self reports of ability measures - many students were struggling to remember the percentages they obtained approximately four months back.

#### **6.3.5 ESTIMATION OF THE STRUCTURAL MODEL**

Three structural models were estimated according to the Anderson and Gerbing's (1988) approach. Their goodness-of-fit measures are given in table 6.1.

---

<sup>2</sup> Second order confirmatory factor analyses of the school and home latent factors were estimated. The home model fit the data well (see appendix B). No good-fitting second order confirmatory factor analysis model for the school latent factor was found. A second order confirmatory factor analysis of the personal factor was not possible because only two first order factors were available (motivation and self-concept). At least three first order factors are needed for identification purposes.

**Table 6.1 Goodness-of-fit indices of models tested**

MODEL	$\chi^2$	DF	$\chi^2/DF$	GFI	AGFI
$M_0$	540.96	149	3.63	0.907	0.869
$M_1$	551.37	152	3.63	0.905	0.869
$M_c$	268.37	83	3.23	0.935	0.906

From table 6.1, the best fitting model by multiple criteria was the constrained model ( $M_c$ ). Model  $M_c$  demonstrated that 17.7% and 70.3% of the variance in physical science achievement and attitude, respectively, were accounted for by the variables in the model. Self-concept and ability had direct effects on achievement whereas home environment had an indirect effect, mainly through self-concept. Motivation and school factors had no significant effects on achievement.

The affective factors of the home, self-concept and motivation contributed to the variance in attitude towards physical science, the home indirectly and the others directly.

The results of this study therefore highlights the importance of the science self-concept as a determinant of science achievement and attitude amongst secondary school students. Not only did the science self-concept influence the science outcomes significantly, it also had significant effects on ability and motivation. These factors were found to play a crucial role in science achievement and attitude by previous research. The exact nature of the effects of self-concept as found in this study needs to be the subject of further research.

Another important conclusion that can be drawn from the results of this study is the process nature of the determinants of science achievement and attitude. The results indicated that the influence of significant others (parents and to a lesser extent, teachers) was mediated by personal factors which had direct effects on science achievement and attitude. It appears that over the years, significant others have shaped students' personalities that, at junior secondary school level, play a major role in determining science outcomes. This finding further indicated the importance of early intervention (both by the family and the school) in the further development and achievement of children at school. Intervention programmes that target secondary school students might find it difficult to correct behaviour entrenched in the earlier years.

Finally, the low and non significant effects of school variables (that is, teacher characteristics and school environment) in the present data set might be indicating what is normally called the "absence of a culture of teaching and learning" in black secondary schools. The processes taking place in

school might mean so little to students that the actions (or omissions) of teachers might go unnoticed. On the adverse side, it might mean that students are so used to mediocrity and abnormal activities happening in schools that they have come to take it as a norm. In such circumstances, only highly resilient students are able to benefit from the endeavours of well intentioned teachers.

## **6.4 RECOMMENDATIONS AND IMPLICATIONS**

The conclusions drawn from the literature and empirical studies highlight several important issues which are described below as recommendations for educational practice. The implications of these recommendations are also discussed.

### **6.4.1 SIGNIFICANT OTHER - STUDENT RELATIONSHIPS**

The theoretical and constrained structural equation models estimated in this study indicated a process nature to the determinants of physical science achievement and attitude. Significant others (parents and, to a lesser effect, teachers) influenced students' affective variables (self-concept, motivation) which in turn influenced science achievement and attitude. The relationship of parents and teachers with students is therefore crucial in enhancing achievement and attitude in school physical science.

#### **6.4.1.1 PARENT - STUDENT RELATIONSHIPS**

A stimulating and supportive environment in the home forms an important element of the child's socialisation and eventual achievement in school physical science. The promotion of a stimulating and supportive home environment, therefore, is imperative. To achieve this, a two pronged strategy could be used.

First, students can be taught about the dynamics of family relationships and their consequences, particularly in relation to their academic achievement and attitudes. The author suggests that this be one of the specific outcomes for learning programmes in Life Orientation. The critical stages where this outcome should be targeted is in the middle and senior phases of the General Education and Training phase. During these early years parental influences are easily transmitted to children who are still in the process of forming a stable self-concept. The self-concept, as shown in chapter five, impacts profoundly on physical science achievement and attitude.

Secondly, parental guidance (which could educate parents about mechanisms to create supportive and stimulating environments in the home) should form an integral part of school-focused

professional development<sup>3</sup> or whole school development planning. In this way parental guidance will be infused within each school and will probably give substance to parental involvement in their children's schooling. Parental involvement in school matters, in the case of black parents, has been shown to be lacking.

#### 6.4.1.2 TEACHER - STUDENT RELATIONSHIPS

Although research studies concerning the impact of teacher - student relationships on science achievement and attitude were scarce, intuition and few studies undertaken thus far indicated the importance of such a relationship. Positive teacher - student relationships are cultivated by teacher initiatives emanating from their positions within the relationship. Teachers are therefore responsible for creating a supportive and stimulating environment in the classroom. To do so, however, requires a supportive environment that will sustain every teacher in the school.

The need for a supportive environment in schools and within the education system prompted the author of this thesis to initiate an investigation into education support services in South Africa. The results of the investigation are reported elsewhere<sup>4</sup> and highlights the following:

- (a) Schools inhabit diverse individuals who have different intellectual, personal, and social needs. Such needs can be addressed by well planned support services for schools since teachers would not be in a position to address all the needs of students, parents, and the community, let alone their own needs.
- (b) The diverse needs of teachers, students, and the like, requires a variety of support services, for example developmental school guidance and counselling programmes, psychological services, school health education, school social work, and the like. Most of these services were either neglected or were not provided in a majority of black schools.

---

<sup>3</sup> Mashile, E.O. (1998) *Teacher Development in a Changing System*. Paper presented to the Southern African Society for Education Conference held at the Kei Mouth Beach Hotel, Eastern Cape Province.

<sup>4</sup> Mashile, E.O. (1999) *Integrating Support Services: the Role of Guidance*. Paper presented to the Education Association of South Africa (36<sup>th</sup> Annual Conference) at Wellington, Western Cape Province.

and

Mashile, E.O. (in press) Education Support Services in South Africa. In Mda, T.V. & Mothata, S. *Critical Issues in South African Education*. Johannesburg: JUTA.

- (c) To address the needs of teachers and schools, an integrated and collaborative approach to support was suggested.

#### 6.4.2 QUALITY OF SCIENCE EDUCATION

The South African Department of Education embarked on a curriculum review late in 1995. This culminated in the unveiling of a new Curriculum 2005 early in 1997. Curriculum 2005 consists of eight learning areas, one of which is Natural Sciences. This learning area comprises aspects of Biology, Physical Science and Geography. Curriculum 2005 was implemented in grade one for the first time in 1998 and in grade two in 1999. In the year 2000, it will be introduced for the first time to grade seven.

It is at grade seven and higher where the greatest challenges in the implementation of Curriculum 2005 will lie. In the case of the Natural Sciences learning area, teachers will be required to develop learning programmes based on four fields, namely (1) the planet earth and beyond, (2) life and living, (3) energy and change and (4) matter and materials.

The ability of teachers to develop such programmes will therefore determine the success or failure of Curriculum 2005 at these middle school years. Most white teachers in previously white schools, unlike their black counterparts in historically black schools, have the necessary academic and material resources to undertake programme development that even academics at institutions of higher learning are finding a daunting task.

The literature study indicated that most black teachers (1) are un-qualified or under-qualified to teach at the levels they are teaching, (2) have limited material resources and (3) demonstrated low levels of involvement and commitment in their work. It is the opinion of the author that these problems can, amongst others, be addressed by the following recommendations.

- (a) *Academic and professional development of teachers should be planned and coordinated centrally.*

The declaration of Colleges of Education into the Higher Education band and their possible integration into universities and technikons makes it possible for teacher education to be controlled centrally by bodies such as the South African Qualifications Authority (SAQA). In addition, Education and Training Quality Assurance (ETQA) bodies will be charged with assuring the quality of teacher education provided at institutions of higher learning. As such, teacher education will circumvent the chaotic state of preservice education reported in the literature study.



Teachers, however, need to be persuaded to participate in education programmes offered by institutions of higher learning. Persuasion is necessary since teachers will not, on their own free will, enroll for In-Service Education and Training (INSET) programmes which are perceived to offer no monetary or other related incentives. The author, realising the declining rate of participation in INSET programmes at higher education institutions, initiated a study to investigate ways of enhancing participation in INSET programmes. The study is reported elsewhere<sup>5</sup> and the results are briefly summarised below.

- An efficient and effective way of providing INSET is through a centralised unit which will plan, coordinate and give a vision for INSET.
- The South African Council of Educators (SACE) must legislate regulations for teachers to demonstrate evidence of Continuous Professional Development (CPD) when renewing their teaching licenses, even for "qualified" teachers. This will ensure that teachers continually improve their knowledge, skills and values pertaining to sound practice and in the process develop capacities for lifelong learning.
- Institutions and organisations offering highly specialised short courses which do not form enough credits for a qualification (for example a certificate) on the National Qualifications Framework (NQF) should team up with universities and technikons and develop an appropriate INSET programme. For example, institutions of higher education, in collaboration with NGOs (say, the Science Education Project) could develop a certificate programme aimed at developing practical work and science process skills. Such programmes could make it easier for teachers to get credit for their learning in INSET programmes whilst gaining the necessary skills that will improve their teaching. Also, a large number of teachers could be reached by the network already established by various NGOs and the infra-structure available in higher education institutions.

(b) *Greater accountability should be required from schools with regard to material resources.*

The Department of Education should not finance school projects which resulted from negligence by school personnel, students or the community. Projects ranging from the fixing of structural damage (buildings) to the supply of damaged or missing textbooks impacts profoundly on the meagre financial resources available for infra-structural development. Continual bailing out of negligent

---

<sup>5</sup> Mashile, E.O. & Vakalisa, N.C.G. (1999) *Accreditation of INSET Programmes for School Educators..* Paper presented at the 11<sup>th</sup> Biennial conference of the South African Association for Research and Development in Higher Education. Belville, Peninsula Technikon.

schools, however noble the task may seem, hinders broader development in other areas, particularly in the technological area. Most newer black schools in urban areas of Gauteng, for example, were electrified and supplied with some television and video recorders for instruction purposes. Some schools were even provided with computers. Only few schools, however, have taken care of these valuable resources and thus deprive students from making use of modern technological instrumentation. In science education, neglect impacts directly in that experimentations and laboratory work cannot be undertaken, thus making it impossible for students to learn the science process skills and other related competencies.

It is the opinion of the author that the Department of Education has adopted a *laissez faire* approach on negligent schools and that greater accountability from schools is required. Negligent schools should receive less and less funding until they demonstrate evidence of improvement in the handling of material resources. Failure by the Department of Education to intervene decisively in curbing negligent behaviour of schools towards material resources will prolong the desperate state of resources in black schools. The gap between historically black and historically white schools in terms of material resources will continue to grow to the detriment of an education system geared towards principles of equity and redress.

(c) *Black teachers' work ethics should be addressed.*

Black education has been plagued by allegations of low teacher involvement and lack of commitment in their work. Teachers should be persuaded to give regular homework activities that will engage students with the learning material. The amount of exposure to the learning material has been reported in the literature to enhance achievement. The students used in this study had little time allocated in doing homework. On average, they spent between one and two hours per week on homework.

Assessment methods, and instructional methods in general, that are used by teachers should be greatly revamped. The dependency on lectures, rote learning, and the like, impacts negatively on students. Their emotional involvement with learning is compromised and this results in lowered achievement and general disregard for learning. Failure is, as a result, a usual phenomenon which is not feared. In their ninth year of schooling (a majority of the sample), the students in this study have experienced failure an average of four times - the maximum allowed in the new dispensation. This translates to failing once every second grade. The change towards an Outcomes-based approach in the curriculum should be encouraged and alternatives to the implementation problems experienced so far should be sought.

Recent developments in SACE (development of code of conduct for teachers) and the Education Labour Relations Council (ELRC) (job descriptions and teacher workloads) are welcomed in that they pave the way for teacher appraisal which would possibly enhance teachers' involvement and commitment in their work.

### 6.4.3 AFFECTIVE FACTORS IN SCIENCE EDUCATION

Affective factors play an important role in students' disposition towards learning. As such affective factors should form an integral part of the schooling process. Curriculum 2005, with its emphasis on an Outcomes-based approach to teaching and learning, highlighted the fact that attitudes (together with knowledge, skills and values) should be incorporated in instruction as an important learning outcome. Teachers should therefore organise learning activities that will enhance students' affective variables. This is particularly important when viewed against the background of the study by Reynolds and Walberg (1992) which found that initial attitudes influence later achievement in science.

The results of this study identified science self-concept and motivation as major determinants of students' attitudes toward physical science. Furthermore, science self-concept was found to be a major determinant of physical science achievement. The teaching of physical science should therefore not be limited to the cognitive domain as has been done by many black teachers so far. Greater involvement of teachers in addressing affective factors would probably enhance students' perceptions of the role teachers play in regard to physical science achievement and attitude, an aspect which was found lacking in the sample used in this study. Mechanisms to enhance students' science self-concept and other affective factors should therefore be pursued by teachers and parents alike.

The mechanism through which science self-concept influence physical science achievement and attitude is beyond the scope of this thesis and is as such recommended for further investigation. Teachers, however, could enhance students' self-concept and other affective variables by doing, amongst others, the following:

- (i) Avoid excessive competition among students. An excessive competitive environment is particularly harmful to slow learners and students who are not proficient in the language of instruction. These students are easily threatened by the standards set in highly competitive classrooms and are thus vulnerable to feelings of despair. Teachers should rather use cooperative learning strategies in which group performance is valued and a sense of belonging is encouraged.

- (ii) The presentation of abstract learning material should be linked to students' developmental levels, that is, to their ability to cope with the material. Teachers will need to assess their students' abilities before teaching abstract concepts that may hinder students' interest and attention. The aim of lessons should not be merely to cover the syllabus, or to speedily dispose of the complex subject matter at hand, but to ensure that students understand and enjoy the material being studied.
- (iii) Teachers must encourage students to experiment at home with concepts introduced at school. In this way parents can be drawn into students' classroom activities. Parental encouragement in school activities has been shown in this study to impact profoundly on both physical science achievement and attitude.

Parents, on the other hand, should be encouraged by teachers to:

- (i) support students by allowing them room and time to do physical science activities;
- (ii) provide necessary material from home that may be requested by teachers for classroom based work. For example, students should feel free to bring items like vinegar, baking powder, *et cetera* from home when learning, say, acids and bases. Using items students are familiar with enhances students' interest and motivation;
- (iii) accompany students on a regular basis to events and sites of scientific interest, thereby enhancing students' interest in science.

## 6.5 LIMITATIONS OF THIS STUDY

A number of limitations were inherent in the present study:

- (a) Sampling variability, especially in multivariate analyses as in the present study, could have influenced the results and consequently the conclusions drawn. The following factors probably influenced the sampling procedure used in this study.
  - (i) The use of the cluster method of sampling, although convenient for practical purposes, might produce kurtosis, deviance from normality and outliers. The first two were not very serious in this study but the presence of outliers was problematic. Problematic in the sense that removing cases with outliers might have created further outliers and a smaller sample size, which is not recommended in analyses of

covariances. Since all cases were used in this study, the results might have been different if outliers were removed.

The sample for future studies should preferably be drawn by using stratified random sampling instead of the cluster method as used in this study. This will help in comparing the fit of the model across different grade levels. In this study the comparison was ruled out due to the small number of grade tens that were found in the schools. The sharp drop in the number of students from grade nine to grade ten illustrates the poor popularity of physical science amongst urban black secondary school students

Similarly, to be able to compare multiple groups according to ethnicity, different schools could be targeted to acquire a sizable number of respondents per ethnic group, although such practices will compromise the principle of randomization.

- (ii) The schools that were selected in the clustering method might be atypical of schools in the population investigated. As such, the conclusions drawn might not necessarily be generalisable over the entire population.
  - (iii) A number of students were not present or did not fill in the questionnaire properly. As such the responses received might be skewed upwards for attitude and perhaps downward for achievement.
- (b) The instruments used were modified from those reported in the literature. The modifications might have brought in deficiencies in the scales. For example, other scales used a five point Likert division whereas a four scale division was used in this study. It was thought that the four point scale would be easier to answer - the effect(s) such changes had on the measurement properties of the scales is(are) unknown.
- (c) The number of items in the final questionnaire were numerous and this could have affected the concentration of students, resulting in them hurrying to finish, furnishing wrong answers, and the like. The number of items in the questionnaire should be reduced because some students were impatient when filling in the questionnaire. Alternatively, a series of measurements can be arranged and the questionnaire could be divided to measure fewer constructs per individual wave of measurement. This, however, should be properly communicated to the principals who often complaint about time taken off for learning.

- (d) Before the questionnaire was finalised, it was decided to change all references to science and other subjects to physical science. Students were thus aware of the target of our investigation and could have responded, in their perception, in a favourable manner. This might perhaps explain the positive attitude found amongst the students.
- (e) The timing of the research could also yield different results, especially with attitudes. The latter are known to change during the course of the year.
- (f) The research was carried out on students from one geographical area and as such the results could portray what happens only in that geographic area.
- (g) Polyserial correlations (recommended by Joreskog and Sorbom, 1989 for categorical variables) were not used since a number of categories contained elements with zero variance. The use of such a matrix would have introduced errors in the analyses. As such composite scores and Maximum Likelihood estimations were utilised.

The results of this study need then be interpreted within the limitations given above.

## **6.6 SUGGESTIONS FOR FUTURE RESEARCH**

The variance accounted for in physical science achievement by the factors used in this study was very low, especially when cognisance is taken that a deliberate effort was made to include most important variables in the model. As such, replication studies using the theoretical model is recommended to investigate if situational forces did not influence the outcome of this research.

As already mentioned in the recommendations, investigations into ways and means in which affective variables (especially the self-concept) could be incorporated in urban black secondary schools, should be initiated. Research in this field is therefore suggested.

Finally, a nation wide random sample is needed in further confirmatory research that will eliminate any form of homogeneity.

## **6.7 CLOSING REMARKS**

The author, during the years he taught physical science in secondary schools, was confronted with a situation in which mediocrity, poor performance and lack of drive predominated amongst students. It dawned upon the author that physical science achievement and attitude, representing educational outcomes in the cognitive and affective domains, needed to be investigated.

After undertaking a literature study on the state of physical science education in South Africa and factors that influence science achievement and attitude, a questionnaire was compiled to measure the identified factors. Structural Equation Modelling techniques were used to study the effects of the identified factors on physical science achievement and attitude. From the results of the theoretical and empirical research, several findings and conclusions were made.

The results of the research indicated a process nature in which the self-concept, motivation and ability mediated the effects of the home on physical science achievement and attitude. Several aspects of the research, however, indicated a need for further investigation into the field of physical science achievement and attitude.

Finally, the author is of the opinion that the findings and recommendations of this study will make a meaningful contribution to the practice of physical science teaching and will give teachers the confidence to accompany their students properly.

## REFERENCES

- ADANEZ, GP. 1989. The Development of Attitudes Towards School and their Influence EN Academic Performance. (Unknown Journal Name) pp.341-349.
- ALEXANDER, N. 1990. *Education and the Struggle for National Liberation in South Africa*. Braamfontein: Skotaville.
- ANC. 1995. *A Policy Framework for Education and Training*. Manzini: Macmillan/African National Congress.
- ANDERSON, JC. & GERBING, DW. 1988. Structural Equation Modeling in Practice: A Review and Recommended Two-Step Approach. *Psychological Bulletin*, vol.103, no.3, pp.411-423.
- ANDERSON, LW. 1985. Attitudes and their Measurement. In HUSEN, T. & POSTLETHWAITE, TN. (Eds) *The International Encyclopaedia of Education*. Volume 1. Oxford: Pergamon Press.
- ANDERSON, DS. 1987. Youth Attitudes and the Planning of Secondary Schools. *Prospects*, vol.17, no.1, pp.49-61.
- ANDERSON, TW. & SCLOVE, SL. 1978. *An Introduction to the Statistical Analysis of Data*. Boston: Houghton Mifflin.
- ASHER, HB. 1983. *Causal Modeling*. Newbury Park, California: SAGE Publications.
- BANDALOS, DL.; YATES, K. & THORNDIKE-CHRIST, T. 1995. Effects of Math Self-Concept, Perceived Self-Efficacy, and Attributions for Failure and Success on Test Anxiety. *Journal of Educational Psychology*, vol.87, no.4, pp.611-623.
- BANU, DP. 1986. Secondary School Students' Attitudes Towards Science. *Research in Science & Technological Education*, vol.4, no.2, pp.195-202.
- BAWA, A. 1994. A National Science and Technology Policy. In KAHN, MJ. (ed) *Science and Technology Education and Training for Economic Development*. Johannesburg: Centre for Education Policy Development.



- BECKER, BJ. 1989. Gender and Science Achievement. A reanalysis of Studies from two Meta-Analysis. *Journal of Research in Science Teaching*, vol.26, pp.141-169.
- BENTLER, PM. 1989. *EQS: Structural Equations Program Manual*. Los Angeles: BMDP Statistical Software.
- BENSON, J. 1989. Structural Components of Statistical Test Anxiety in adults: An Exploratory Model. *Journal of Experimental Education*, vol.57, pp.247-261.
- BINIAMINOV, I. & GLASMAN, NS. 1983. School Determinants of Student Achievement in Secondary Education. *American Educational Research Journal*, vol.20, no.2, pp.251-268.
- BOLLEN, KA. 1989. *Structural Equations with Latent Variables*. New York: Wiley.
- BOLLEN, KA. & LONG, JS. 1993. (Eds). *Testing Structural Equation Models*. Newbury Park: Sage Publications.
- BONG, M. 1997. Generality of Academic Self-Efficacy Judgements: Evidence of Hierarchical Relations. *Journal of Educational Psychology*, vol.89, no.4, pp.696-709.
- BORG, WR. & GALL, MD. 1989. *Educational Research: An Introduction*. New York: Longman.
- BOTHA, H.L. & CILLIERS, C.D. 1993. Program for Educationally Disadvantaged Pupils in South Africa: A Multi-Disciplinary Approach. *South African Journal of Education*, vol.13, no.2, pp.55-60.
- BRADFORD, LW. 1989. *The Oxford Dictionary*. Oxford: Clarendon Press.
- BRANTLINGER, E. 1990. Low-Income Adolescents' Perceptions of School, Intelligence, and Themselves as Students. *Curriculum Inquiry*, vol.20, no.3, pp.305-324.
- BURDEN, RL. & FRASER, BJ. 1993. Use of Classroom Environment Assessments in School Psychology: A British Perspective. *Psychology in the Schools*, vol.30, pp.232-240.
- CALDAS, SJ. 1992. Using multiple Regression to Predict Achievement: A Reply to Klingele and Warrick; Penny and Bond. *The Journal of Educational Research*, vol.85, no.3, pp.325-326.
- CALDWELL, GP. & GINTHER, DW. 1996. Differences in Learning Styles of Low Socioeconomic Status for Low and High Achievers. *Education*, vol.117, no.1, pp.141-147.

- CARNEGIE COMMISSION ON SCIENCE, TECHNOLOGY AND GOVERNMENT. 1991. *In the National Interest: The Federal Government in the Reform of K-12 Math and Science Education*. New York: Carnegie Commission.
- CASTEJON, JL. & VERA-MUNOZ, MI. 1996. A Causal Model about the Individual and Contextual Determinants of Academic Achievement. *The High School Journal*, vol.80, no.1, pp.21-27.
- CHED. 1991a. *A Curriculum Model for South Africa*. Pretoria: UNISA.
- CHED. 1991b. *Education Renewal Strategy*. Pretoria: UNISA.
- CHEEK, DW. 1992. *Thinking Constructively about Science, Technology and Society Education*. New York: State University of New York Press.
- CHIARELOTT, L. & CZERNIAK, C. 1987. Science Anxiety. Implications for Science Curriculum and Teaching. *Clearing House*, vol.60, no.5, pp.202-205.
- CHRISTIE, P. 1992. From Crisis to Transformation: Education on Post-apartheid South Africa. *Australian Journal of Education*, vol.36, no.1, pp.38-52.
- CLARK, ML. 1986. Predictors of Scientific Majors for Black and White College Students. *Adolescence*, vol.21, no.81, pp.205-213.
- CLIFF, N. 1983. Some Cautions concerning the Application of Causal Modeling Methods. *Multivariate Behavioral Research*, vol.18, pp.115-126.
- CLIFTON, RA. 1978. *Socio-economic status, Attitudes, and Educational Performance*. IEA Monograph Studies No.8.
- COHEN, J. 1988. *Statistical Power Analysis for the Behavioral Sciences* (2nd Edition). Hillsdale: Erlbaum.
- COOPER, D. 1995. Technikons and Higher Education Restructuring. *Comparative Education*, vol.31, no.2, pp.243-260.
- CRANE, J. 1996. Effects of Home Environment, SES, and Maternal Test Scores on Mathematics Achievement. *The Journal of Educational Research*, vol.89, no.5, pp.305-314.

- CUTTANCE, P. & ECOB, R. (Editors) 1987. *Structural Modeling by Example. Applications in Educational, Sociological, and Behavioral Research*. Cambridge: Cambridge University Press.
- DEBOER, GE. 1987. Predicting Continued Participation in College Chemistry for Men and Women. *Journal of Research in Science Teaching*, vol.24, no.6, pp.527-38.
- DE JONG, PF. 1993. The Relationship between Students' Behaviour at Home and Attention and Achievement in Elementary School. *British Journal of Educational Psychology*, vol.63, pp.201-213.
- DEPARTMENT OF NATIONAL EDUCATION (DNE). 1993. *Education Realities in South Africa*. NATED 02-300 (93/12). Pretoria: National Education Policy Branch, Department of National Education.
- DE VETTA, H.M. 1993. The Reliability of Black Matriculation Results. *South African Journal of Higher Education*, vol.7, no.1, pp.11-20.
- DONN, G. 1995. Curriculum Innovation in South Africa's Post-Apartheid School System. *Science, Technology and Development*, vol.13, no.2, pp.203-224.
- DOSTAL, E. (ed). 1990. *Education for South Africa's Future*. Institute for Futures Research: University of Stellenbosch.
- DRUVA, CA. & ANDERSON, RD. 1983. Science Teacher Characteristics by Teacher Behavior and by Student Outcome: A Meta-Analysis of Research. *Journal of Research in Science teaching*, vol.20, pp.467-479.
- DU TOIT, C.J. & LACHMANN, G. 1997. The Learning of Chemistry through Demonstrations to Large Audiences. *South African Journal of Education*, vol.17, no.1, pp.41-48.
- DU TOIT, C.J.; LACHMANN, G. & NEL, SJ. 1991. Survey of the Influence of a Demonstration Programme on the Attitude of High School Students towards Chemistry. *South African Journal of Education*, vol.11, no.1, pp.49-53.
- DU TOIT, C.J.; LACHMANN, G. & NEL, SJ. 1992. Survey of Factors Influencing the Attitude of Afrikaans-Speaking High School and University Students towards Chemistry. *South African Journal of Education*, vol.12, no.3, pp.261-266.

- ECOB, R. & CUTTANCE, P. 1987. An Overview of Structural Equation Modeling. In CUTTANCE, P. & ECOB, R. (Editors) 1987. *Structural Modeling by Example. Applications in Educational, Sociological, and Behavioral Research*. Cambridge: Cambridge University Press.
- EGGEN, P. & KAUCHAK, D. 1997. *Educational Psychology. Windows on Classrooms*. New Jersey: Merrill-Prentice Hall.
- FISHBEIN, M. & AJZEN, I. 1975. *Belief, attitude, Intention, and Behavior*. Reading, MA: Addison-Wesley.
- FLEMING, ML. & MALONE, MR. 1983. The Relationship of Student Characteristics and Student Performance in Science as viewed by Meta-Analysis Research. *Journal of Research in Science Teaching*, vol.20, no.5, pp.481-495.
- FLINK, C.; BOGGIANO, AK. & BARRET, M. 1990. Controlling Teaching Strategies: Undermining Children's Self-Determination and Performance. *Journal of Personality and Social Psychology*, vol.59, pp.916-924.
- FRASER, BJ. 1986. *Classroom Environment*. London: Croom Helm.
- FRASER, BJ. 1989. Twenty Years of Classroom Climate Work: Progress and Prospect. *Journal of Curriculum Studies*, vol.21, pp.307-325.
- FRASER, BJ. & FISHER, D. 1982. Predicting Students' Outcomes from their Perceptions of Classroom Psychosocial Environment. *American Educational Research Journal*, vol.19, pp.498-518.
- FRASER, BJ.; MALONE, JA. & NEALE, JM. 1989. Assessing and Improving the Psychosocial Environment of Mathematics Classrooms. *Journal of Research in Mathematics Education*, vol.20, pp.191-201.
- FRASER, BJ.; WALBERG, HJ.; WELCH, WW. & HATTIE, JA. 1987. Educational Productivity. *International Journal of Educational Research*, vol.11, no.2, pp.145-252.
- FREEDMAN, DA. 1987. As Others See Us: A Case Study in Path Analysis. *Journal of Educational Statistics*, vol.12, no.2, pp.101-128.
- FREUND, RJ. & WILSON, WJ. 1985. *Statistical Methods*. San Diego: Academic Press.

- GABLE, RK. 1986. *Instrument Development in the Affective Domain*. Kluwer: Nijhoff Publishing.
- GAGE, NL. & BERLINER, DC. 1992. *Educational Psychology*. (5th Edition) Boston: Houghton Mifflin Company.
- GERMANN, PJ. 1988. Development of the Attitude Toward Science in School Assessment and its use to Investigate the Relationship between Science Achievement and Attitude Toward Science in School. *Journal of Research in Science Teaching*, vol.25, no.8, pp.689-703.
- GERMANN, PJ. 1994. Testing a Model of Science Process Skills Acquisition: An Interaction with Parents' Education, Preferred Language, Gender, Science Attitude, Cognitive Development, Academic Ability, and Biology Knowledge. *Journal of Research in Science Teaching*, vol.31, no.7, pp.749-783.
- GLASS, GV.; MCGAW, B. & SMITH, ML. 1981. *Meta-Analysis in Social Research*. Beverly Hills: SAGE Publications.
- GOETZ, PW. (Editor-in-chief) 1986. *The New Encyclopaedia Britannica, Macropaedia*. Volume 25. Encyclopaedia Britannica, Inc.
- GOLDBERGER, AS. 1973. Structural Equation Models: An Overview. In GOLDBERGER, AS. & DUNCAN, OD. (Eds) 1973. *Structural Equation Models in the Social Sciences*. New York: Seminar Press.
- GOLDBERGER, AS. & DUNCAN, OD. (Eds) 1973. *Structural Equation Models in the Social Sciences*. New York: Seminar Press.
- GORDON, A. 1986. Environmental Constraints and their Effect on the Academic Achievement of Urban Black Children in South Africa. *South African Journal of Education*, vol.6, no.1, pp.70-74.
- GOUWS, E. & KRUGER, N. 1994. *The Adolescent. An Educational Perspective*. Johannesburg: Butterworths.
- GRAY, DJ. 1989. *A Preliminary Investigation into Modular Physical Science for Standards 9 and 10*. Pretoria: Human Sciences Research Council.
- GREENFIELD, TA. 1996. Gender, Ethnicity, Science Achievement, and Attitudes. *Journal of Research in Science Teaching*, vol.33, no.8, pp.901-933.

- HALADYNA, T.; OLSEN, R. & SHAUGHNESSY, J. 1982. Relations of Student, Teacher and Learning Environment Variables to Attitudes Toward Science. *Science Education*, vol.66, pp.671-687.
- HAMRICK, L. & HARTY, H. 1987. Influence of Resequencing General Science Content on the Science Achievement, Attitudes Toward Science, and Interest in Science of Sixth Grade Students. *Journal of Research in Science Teaching*, vol.24, no.1, pp.15-25.
- HANDLEY, HM. & MORSE, LN. 1984. Two-Year Study Relating Adolescents' Self-Concept and Gender Role Perceptions to Achievement and Attitudes Toward Science. *Journal of Research in Science Teaching*, vol.21, no.6, pp.599-607.
- HARLEN, W. 1993. Education for Equal Opportunities in a Scientifically Literate Society. In WHITELEGG, E.; THOMAS, J. & TRESMAN, S. (Eds). *Challenges and Opportunities for Science Education*. London: Paul Chapman Publishing/Open University.
- HAUKOOS, GD. & PENICK, JE. 1987. Interaction Effect of Personality Characteristics, Classroom Climate, and Science Achievement. *Science Education*, vol.71, no.5, pp.735-743.
- HEDGES, LV. & OLKIN, I. 1985. *Statistical Methods for Meta-Analysis*. Orlando: Academic Press.
- HEIN, C. & LEWKO, JH. 1994. Gender Differences in Factors Related to Parenting Style: A Study of High Performing Science Students. *Journal of Adolescent Research*, vol.9, no.2, pp.262-281.
- HERMAN, HD. 1995. School-leaving Examinations, Selection and Equity in Higher Education in South Africa. *Comparative Education*, vol.31, no.2, pp.261-274.
- HILL, OW.; PETTUS, WC. & HEDIN, BA. 1990. Three Studies of Factors Affecting the Attitudes of Blacks and Females Toward the Pursuit of Science and Science-related Careers. *Journal of Research in Science Teaching*, vol.27, no.4, pp.289-314.
- HODSON, D. 1993. In Search for a Rationale for Multicultural Science Education. *Science Education*, vol.77, no.6, pp.685-711.
- HOUSE, DJ. 1993. Cognitive-Motivational Predictors of Science Achievement. *International Journal of Instructional Media*, vol.20, no.2, pp.155-162.
- HUNTER, JE. SCHMIDT, FL.; & JACKSON, GB. 1982. *Meta-Analysis. Cumulating Research findings Across Studies*. Beverly Hills: SAGE Publications.

- IRWIN, A. 1995. *Citizen Science. A Study of People, Expertise and Sustainable Development*. London: Routledge.
- JACOBS, LJ.; OOSTHUIZEN, JD.; LE ROUX, AC.; OLIVIER, A.; BESTER, G. & MELLET, SM. 1989. *Special Empirical Education. Only Study Guide for OSE402-E*. Pretoria: University of South Africa.
- JACOBS, JE. 1991. Influence of Gender Stereotypes on Parent and Child Mathematics Attitudes. *Journal of Educational Psychology*, vol.83, no.4, pp.518-527.
- JEANS, BA. 1994. Elementary Science Education: Text, Content and Pedagogy. *South African Journal of Education*, vol.14, no.2, pp.87-93.
- JENKINS, E. 1993. Scientific Literacy and School Science Education. In WHITELEGG, E.; THOMAS, J. & TRESMAN, S. *Challenges and Opportunities for Science Education*. London: Paul Chapman Publishing/The Open University.
- JONES, G. 1971. *The Role of Science & Technology in Developing Countries*. London: Oxford University Press.
- JORESKOG, KG. & SORBOM, D. 1989. *LISREL 7. A Guide to the Program and Applications*. (2nd Edition) Chicago: SPSS INC.
- JOVANOVIC, J.; SOLANO-FLORES, G. & SHAVELSON, RJ. 1994. Performance-Based Assessments. Will Gender Differences in Science Achievement be Eliminated? *Education and Urban Society*, vol.26, no.4, pp.352-366.
- KAHN, M. 1994. Science and Mathematics education in the Formal System. In KAHN, MJ. (ed) *Science and Technology Education and Training for Economic Development*. Johannesburg: Centre for Education Policy Development.
- KEEVES, JP. 1974. *The Home, The School and Achievement in Mathematics and Science*. Hawthorn, Victoria: Australian Council for Educational Research.
- KERLINGER, FN. 1986. *Foundations of Behavioural Research*. 3<sup>rd</sup> Edition. London: Holt, Rinehart and Winston.

- KOBALLA, TR. 1992. Persuasion and Attitude Change in Science Education. *Journal of Research in Science Teaching*, vol.29, no.1, pp.63-80.
- KREMER, BK. & WALBERG, HJ. 1981. A Synthesis of Social and Psychological Influence on Science Learning. *Science Education*, vol.65, pp.11-23.
- KUPER, A. & KUPER, J. (Editors) 1985. *The Social Science Encyclopaedia*. London: Kegan Paul.
- LAWRENZ, F. & HUFFMAN, D. 1996. Considerations in Structural Modeling Research. *Journal of Research in Science Teaching*, vol.33, no.3, pp.339-341.
- LEE, VE. & BURKAM, DT. 1996. Gender Differences in Middle Grade Science Achievement: Subject Domain, Ability Level, and Course Emphasis. *Science Education*, vol.80, no.6, pp.613-650.
- LEES, LH. 1994. Educational Inequality and Academic Achievement in England and France. *Comparative Education Review*, vol.38, no.1, pp.65-87.
- MA, X. & KISHOR, N. 1997. Attitude Toward Self, Social Factors, and Achievement in Mathematics: A Meta-Analytic Review. *Educational Psychology Review*, vol.9, no.2, pp.89-113.
- MABANDLA, L. 1995. Reconstructing Education - Problems and Issues. CESA academic lecture. *Lyra Academica*, vol.10, no.1, pp.5-12.
- MACDONALD, MA. & ROGAN, JM. 1990. Innovation in South African Science Education (Part 2): Factors Influencing the Introduction of Instructional Change. *Science Education*, vol.74, no.1, pp.119-132.
- MACMILLAN, DL.; WIDAMAN, KF.; BALOW, IH.; HEMSLEY RE. & LITTLE, TD. 1992. Differences in Adolescent School Attitudes as a Function of Academic Level, Ethnicity, and Gender. *Learning Disability Quarterly*, vol.15, pp.39-50.
- MAQSUD, M. & KHALIQUE, CM. 1991. Relationships of some Socio-Personal Factors to Mathematics Achievement of Secondary School and University Students in Bophuthatswana. *Education Studies in Mathematics*, vol.22, pp.377-390.
- MARSH, HW. 1990. The Causal Ordering of Academic Self-Concept and Academic Achievement: A Multiwave, Longitudinal Path Analysis. *Journal of Educational Psychology*, vol.82, no.4, pp.646-656.



- MARSH, HW. 1991. Public, Catholic Single-Sex, and Catholic Coeducational High Schools: Their Effects on Achievement, Affect, and behaviors. *American Journal of Education*, vol.99, no.3, pp.320-356.
- MARSH, HW. 1994. Using the National Longitudinal Study of 1988 to Evaluate Theoretical Models of Self-Concept: The Self-Description Questionnaire. *Journal of Educational Psychology*, vol.86, no.3, pp.439-456.
- MARSH, HW. & YEUNG, AS. 1997. Causal Effects of Academic Self-Concept on Academic Achievement: Structural Equation Models of Longitudinal Data. *Journal of Educational Psychology*, vol.89, no.1, pp.41-54.
- MASHILE, EO. 1995. *Political and Social factors related to Secondary School Pupils' Attitude Towards School*. (MEd). Pretoria: University of South Africa.
- MASITSA, MG. 1995. *The Establishment of a Learning Culture as a Prerequisite for Academic Achievement*. (DEd thesis). Pretoria: University of South Africa.
- MAU, W. 1997. Parental Influences on the High School Student's Academic Achievement: A Comparison of Asian Immigrants, Asian Americans, and White Americans. *Psychology in the Schools*, vol.34, no.3, pp.267-277.
- MELLET, SM. 1986. *Die Motivering van Wiskundeleerlinge*. (DEd. proefskrif). Pretoria: Universiteit van Suid Afrika.
- MENIS, J. & FRASER, BJ. 1992. Chemistry Achievement among Grade 12 Students in Australia and the United States. *Research in Science and Technological Education*, vol.10, no.2, pp.131-141.
- MILLAR, R. & DRIVER, R. 1987. Beyond Processes. *Studies in Science Education*, vol.14, pp.33-62.
- MISITI, FL.; SHRIGLEY, RL. & HANSON, L. 1991. Science Attitude Scale for Middle School Students. *Science Education*, vol.75, no.5, pp.525-540.
- MOLLER, V.(ed) 1991. *Lost Generation Found. Black Youth at Leisure*. Durban: Indicator Project South Africa.
- MORDI, C. 1991. Factors Associated with Pupils' Attitudes Towards Science in Nigerian Primary Schools. *Research in Science & Technological Education*, vol.9, no.1, pp.39-49.

- MORRIS, N. 1973. *The Heritage Illustrated Dictionary of the English Language*. New York: McGraw-Hill.
- MYERS, RE. & FOUTS, JT. 1992. A Cluster Analysis of High School Science Classroom Environments and Attitude Toward Science. *Journal of Research in Science Teaching*, vol.29, no.9, pp.929-937.
- NAPIER, J. & RILEY II, JP. 1985. The Relationship between Affective Determinants and Achievement in Science for Seventeen-Year-Olds. *Journal of Research in Science Teaching*, vol.22, no.4, pp.365-383.
- NCHE 1996. *A Framework for Transformation: Report*. Pretoria: National Commission on Higher Education (South Africa).
- NEPI. 1992a. *Human Resource Development*. Cape Town: Oxford University Press/NECC.
- NEPI. 1992b. *Teacher Education*. Cape Town: Oxford University Press/NECC.
- NEPI. 1992c. *Education Planning, Systems & Structure*. Cape Town: Oxford University Press/NECC.
- NEPI. 1992d. *Curriculum*. Cape Town: Oxford University Press/NECC.
- OGUNNIYI, MB. 1995. The Development of Science Education in Botswana. *Science Education*, vol.79, no.1, pp.95-109.
- OLIVER, JS. & SIMPSON, RD. 1988. Influence of Attitude Toward Science, Achievement Motivation, and Science Self-Concept on Achievement in Science: A Longitudinal Study. *Science Education*, vol.72, no.2, pp.143-155.
- PEDHAZUR, EJ. & SCHMELKIN, LP. 1991. *Measurement, Design, and Analysis: An Integrated Approach*. Hillsdale, New Jersey: Lawrence Erlbaum Associates.
- POSTMA, F. 1993. Learning Strategies in Chemistry. *South African Journal of Higher Education*, vol.7, no.3, pp.102-103.
- RENNIE, LJ. & PUNCH, KF. 1991. The Relationship between Affect and Achievement in Science. *Journal of Research in Science Teaching*, vol.28, no.2, pp.193-209.

- REYNOLDS, A.J. & WALBERG, H.J. 1991. A Structural Model of Science Achievement. *Journal of Educational Psychology*, vol.83, no.1, pp.97-107.
- REYNOLDS, A.J. & WALBERG, H.J. 1992. A Structural Model of Science Achievement and Attitude: An extension to High School. *Journal of Educational Psychology*, vol.84, no.3, pp.371-382.
- ROSENTHAL, R. 1984. *Meta-Analytic Procedures for Social Research*. Beverly Hills: SAGE Publications.
- RSA. 1996. *The Organisation, Governance and Funding of Schools*. Education white paper 2. Government Gazette number 16987. Pretoria: Department of Education.
- RUTHERFORD, M. & WATSON, P. 1990. Selection of Students for Science Courses. *South African Journal of Education*, vol.10, no.4, pp.353-359.
- SAMUEL, J. 1990. A New Education System for a New South Africa. In *Transforming Schools in South Africa*. Moubray:IDASA.
- SANDER, CL. 1988. Matriculation Performance in Physical Science and Mathematics and the failure Rate in Chemistry at University. *South African Journal of Education*, vol.8, no.4, pp.359-362.
- SAPP, G. 1992. Science Literacy: A Discussion and an Information-based Definition. *College and Research Libraries*, vol.53, no.1, pp.21-30.
- SARIS, WE. & STRONKHORST, LH. 1984. *Causal Modelling in Nonexperimental Research: An Introduction to the LISREL Approach*. Amsterdam: Sociometric Research Foundation.
- SCHIBECI, RA. 1989. Home, School, and Peer Group Influences on Student Attitudes and Achievement in Science. *Science Education*, vol.73, no.1, pp.13-24.
- SCHIBECI, RA. & RILEY, JP. 1986. Influence of Students' Background and Perceptions on Science Attitudes and Achievement. *Journal of Research in Science Teaching*, vol.23, no.3, pp.177-187.
- SEARLES, WB. 1963. *The Relationship between the Perceived Emotional Climate of the Home of College Students and certain variables in their Functioning related to Self-Concept and Academic Functioning*. (DEd Thesis) University of Maryland.

- SIMPSON, RD. & OLIVER, JS. 1990. A Summary of Major Influences on Attitude Toward and Achievement in Science among Adolescent Students. *Science Education*, vol.74, no.1, pp.1-18.
- SIMPSON, RD. & TROOTS, KM. 1982. Influences of Commitment to the Learning of Science among Adolescent Students. *Science Education*, vol.66, no.5, pp.763-781.
- SOLOMON, J. 1996. Student Learning on a GNVQ Science Course: Motivation and Self-Esteem. *SSR*, vol.78 (280), pp.37-44.
- SOUTHERN AFRICAN CONFERENCE ON RELEVANT EDUCATION. 1992. Pretoria: Human Sciences Research Council.
- STAVER, JR. & WALBERG, HJ. 1986. An Analysis of Factors that Affect Public and Private School Science Achievement. *Journal of Research in Science Teaching*, vol.23, no.2, pp.97-112.
- STEINKAMP, MW. & MAEHR, ML. 1983. Affect, Ability, and Science Achievement: A Quantitative Synthesis of Correlational Research. *Review of Educational Research*, vol.53, no.3, pp.369-396.
- SWEITZER, GL. & ANDERSON, RD. 1983. A Meta-Analysis of Research on Science Teacher Education Practices Associated with Inquiry Strategy. *Journal of Research in Science Teaching*, vol.20, no.5, pp.453-466.
- TAMIR, P. 1987. Some Factors which Affect Science Achievement of High School Seniors in Israel. *Research in Science & Technological Education*, vol.5, no.1, pp.69-92.
- TAMIR, P. 1989. Home and School effects on Science Achievement of High School Students in Israel. *Journal of Educational Research*, vol.83, no.1, pp.30-39.
- TAMIR, P. 1991. Factors Associated with the Acquisition of Functional Knowledge and Understanding of Science. *Research in Science & Technological Education*, vol.9, no.1, pp.17-37.
- TOCCI, CM. & ENGELHARD, G. 1991. Achievement, Parental Support, and Gender Differences in Attitude toward Mathematics. *Journal of Educational Research*, vol.84, no.5, pp.280-6.
- UGUROGLU, ME.; SCHILLER, DP. & WALBERG, HJ. 1981. A Multidimensional Motivation Instrument. *Psychology in the Schools*, vol.18, pp.279-285.

- UGUROGLU, ME. & WALBERG, HJ. 1986. Predicting Achievement and Motivation. *Journal of Research and Development in Education*, vol.19, no.3, pp.1-12.
- VAN DEN AARDWEG, EM. & VAN DEN AARDWEG, ED. 1993. *Psychology of Education. A Dictionary for Students*. Pretoria: E & E Enterprises.
- VAN DER LINDE, HJ.; VAN DER WAL, RWE. & WILKINSON, A. 1994. Practical Work in Science Teaching in Developing Communities. *South African Journal of Education*, vol.14, no.1, pp.48-52.
- WAGNER, RK.; TORGESEN, PL.; SIMMONS, K. & RASHOTTE, CA. 1993. Development of Young Readers' Phonological Processing Abilities. *Journal of Educational Psychology*, vol.85, no.1, pp.83-103.
- WELCH, WW.; ANDERSON, RE. & HARRIS, LJ. 1982. The Effects of Schooling on Mathematics Achievement. *American Educational Research Journal*, vol.19, pp.145-153.
- WEINBURGH, M. 1995. Gender Differences in Student Attitudes Toward Science: A Meta-Analysis of the Literature from 1970 to 1991. *Journal of Research in Science Teaching*, vol.32, no.4, pp.387-398.
- WHITE, KR. 1982. The Relation between Socioeconomic Status and Academic Achievement. *Psychological Bulletin*, vol.91, pp.461-481.
- WILKINSON, FJ.; REUTER, MA. & KRIEL, CF. 1987. An Analysis of the Problems Experienced by Teachers of Physical Science in Some Developing States within the South African context. *South African Journal of Education*, vol.7, no.1, pp.47-52.
- WILSON, VL. 1983. A Meta-Analysis of the Relationship between Science Achievement and Science Attitude: Kindergarten through College. *Journal of Research in Science Teaching*, vol.20, no.9, pp.839-850.
- WOOLNOUGH, BE. 1997. Motivating Students or Teaching Pure Science? *School Science Review*, vol.78 (285), pp.67-72.
- YOUNG, DJ.; REYNOLDS, AJ. & WALBERG, HJ. 1996. Science Achievement and Educational Productivity: A Hierarchical Linear Model. *The Journal of Educational Research*, vol.89, no.5, pp.272-278.

ZYMELMAN, M. 1990. *Science, Education, and Development in Sub-Saharan Africa*. Washington, DC:  
The World Bank.

# **APPENDIX A**

# PSYCHO-SOCIAL FACTORS QUESTIONNAIRE

## DIRECTIONS

(a) This questionnaire contains statements on how you feel about activities in your physical science class, your school and your home. It also contains statements on how you feel about yourself. This is **NOT** a test and there are therefore no **RIGHT** or **WRONG** answers. **Your opinion** is what is wanted.

(b) Make sure that you answer **ALL** the questions.

(c) Answer each question by writing down the appropriate number in the square on the right. The numbers have the following meaning:

4	=	Strongly Agree
3	=	Agree
2	=	Disagree
1	=	Strongly Disagree.

(d) For example,

**Statement:** I enjoy playing tennis.

If playing tennis bores you a lot, you should answer like this:

I enjoy playing tennis |  k1

If, however, you enjoy playing tennis, but not much, you should answer like this:

I enjoy playing tennis |  k1

(e) Provide your choice to each statement truthfully. In other words be honest. No one in your school will see what you answered. All the information you provide will be treated with **confidentiality**.

(f) Thank you for your cooperation.

*Please turn over to start answering . . . .*



**Strongly Agree = 4**

**Agree = 3**

**Disagree = 2**

**Strongly Disagree = 1**

- |    |  |                          |     |
|----|--|--------------------------|-----|
| 1  | Physical science helps a person think logically                          | <input type="checkbox"/> | K1  |
| 2  | Physical science is fun  | <input type="checkbox"/> | K2  |
| 3  | I feel a definite positive reaction to physical science                  | <input type="checkbox"/> | K3  |
| 4  | My mother (female guardian) encourages me to do well in physical science | <input type="checkbox"/> | K4  |
| 5  | Our school laboratory or laboratories are used properly                  | <input type="checkbox"/> | K5  |
| 6  | My physical science teacher makes science exciting                       | <input type="checkbox"/> | K6  |
| 7  | My father (male guardian) expects me to do well in physical science      | <input type="checkbox"/> | K7  |
| 8  | I try hard in physical science   | <input type="checkbox"/> | K8  |
| 9  | Physical science is a topic which I enjoy studying                       | <input type="checkbox"/> | K9  |
| 10 | I fool around in the physical science class                              | <input type="checkbox"/> | K10 |
| 11 | Physical science is interesting to me                                    | <input type="checkbox"/> | K11 |
| 12 | I would rather be doing other things besides studying physical science   | <input type="checkbox"/> | K12 |
| 13 | I find it hard to think in terms of physical science equations           | <input type="checkbox"/> | K13 |
| 14 | Compared to others my age I am good at physical science                  | <input type="checkbox"/> | K14 |
| 15 | My mother (female guardian) knows a lot about sciences                   | <input type="checkbox"/> | K15 |
| 16 | Work in physical science classes is easy for me                          | <input type="checkbox"/> | K16 |
| 17 | I would like to learn more about physical science                        | <input type="checkbox"/> | K17 |
| 18 | I feel insecure in a physical science class                              | <input type="checkbox"/> | K18 |
| 19 | My father (male guardian) knows a lot about sciences                     | <input type="checkbox"/> | K19 |
| 20 | Our school building is well kept   | <input type="checkbox"/> | K20 |
| 21 | I feel safe at school  | <input type="checkbox"/> | K21 |

**Strongly Agree = 4**

**Agree = 3**

**Disagree = 2**

**Strongly Disagree = 1**

- 22 My physical science teacher really likes science  K22
- 23 I try harder if I get bad marks/symbols in physical science  K23
- 24 I am afraid to handle chemical substances  K24
- 25 My physical science teacher is enthusiastic  K25
- 26 When we study physical science in school, we waste a lot of time  K26
- 27 My mother (female guardian) expects me to do well in physical science  K27
- 28 I learn things quickly in physical science  K28
- 29 Our school library is functioning well  K29
- 30 I do not like physical science  K30
- 31 During physical science class, I usually am interested  K31
- 32 If I knew I would never go to physical science class again, I would feel sad  K32
- 33 Physical science makes me feel uncomfortable  K33
- 34 I would be interested to study further in physical science  K34
- 35 Physical science is fascinating and fun  K35
- 36 My physical science teacher wants his/her mistakes pointed out  K36
- 37 The feeling that I have towards physical science is a good feeling  K37
- 38 I'm hopeless when it comes to physical science  K38
- 39 When I hear the word physical science, I have a feeling of dislike  K39
- 40 I feel at ease with physical science  K40
- 41 Physical science is boring  K41
- 42 Physical science is useful in everyday problems  K42

**Strongly Agree = 4**

**Agree = 3**

**Disagree = 2**

**Strongly Disagree = 1**

- |    |   |                          |     |
|----|---|--------------------------|-----|
| 43 | My mother (female guardian) would like me to follow a career in science (scientist, doctor, engineer, etc.) | <input type="checkbox"/> | K43 |
| 44 | It is important to know physical science to get a good job  | <input type="checkbox"/> | K44 |
| 45 | I would like to pursue Physical science as a career   | <input type="checkbox"/> | K45 |
| 46 | My father (male guardian) would like me to follow a career in science (scientist, doctor, engineer, etc.)   | <input type="checkbox"/> | K46 |
| 47 | I would like to do Physical science experiments in the laboratory   | <input type="checkbox"/> | K47 |
| 48 | I like practical work in Physical science   | <input type="checkbox"/> | K48 |
| 49 | My father (male guardian) encourages me to do well in physical science                                      | <input type="checkbox"/> | K49 |
| 50 | I wait until the last minute before studying physical science   | <input type="checkbox"/> | K50 |
| 51 | Physical science is one of my best subjects   | <input type="checkbox"/> | K51 |
| 52 | I attend all my physical science classes regularly  | <input type="checkbox"/> | K52 |
| 53 | My physical science teacher shares opinions on science  | <input type="checkbox"/> | K53 |
| 54 | I will use physical science in many ways as an adult  | <input type="checkbox"/> | K54 |
| 55 | If I start a new physical science project, I finish it  | <input type="checkbox"/> | K55 |
| 56 | My parents (guardians) check on whether I had done my homework  | <input type="checkbox"/> | K56 |
| 57 | My physical science teacher encourages me to state my own opinions  | <input type="checkbox"/> | K57 |
| 58 | I would be successful if I put in more effort in physical science   | <input type="checkbox"/> | K58 |
| 59 | In our school, students fight among themselves  | <input type="checkbox"/> | K59 |
| 60 | If I try something new in physical science, I like it to be easy  | <input type="checkbox"/> | K60 |
| 61 | I am proud of my physical science work  | <input type="checkbox"/> | K61 |
| 62 | My parents (guardians) limit the amount of time I spend watching TV or playing video games                  | <input type="checkbox"/> | K62 |

**Strongly Agree = 4**

**Agree = 3**

**Disagree = 2**

**Strongly Disagree = 1**

- |  |                          |     |
|--|--------------------------|-----|
| 63 My physical science teacher takes a personal interest in me               | <input type="checkbox"/> | K63 |
| 64 I would like to do well in physical science                               | <input type="checkbox"/> | K64 |
| 65 In our school, students disobey teachers                                  | <input type="checkbox"/> | K65 |
| 66 I try new physical science activities at home                             | <input type="checkbox"/> | K66 |
| 67 I have a habit of making a mess of my physical science work               | <input type="checkbox"/> | K67 |
| 68 My parents (guardians) give me special privileges when I get good symbols | <input type="checkbox"/> | K68 |
| 69 My physical science teacher admits when he/she does not know something    | <input type="checkbox"/> | K69 |
| 70 I try to do my physical science tasks fully                               | <input type="checkbox"/> | K70 |
| 71 When I try to do something in physical science, I plan carefully          | <input type="checkbox"/> | K71 |
| 72 My parent(s) or guardian(s) attend school events in which I participate   | <input type="checkbox"/> | K72 |
| 73 In our school students talk bad or argues with teachers                   | <input type="checkbox"/> | K73 |
| 74 When I do something well in physical science, It is because I was lucky   | <input type="checkbox"/> | K74 |
| 75 I pay attention in the physical science class                             | <input type="checkbox"/> | K75 |
| 76 My parent(s) or guardian(s) discuss with me the things I studied in class | <input type="checkbox"/> | K76 |
| 77 My parents/guardians help me with my homework                             | <input type="checkbox"/> | K77 |
| 78 My physical science teacher recognizes my right to my own opinions        | <input type="checkbox"/> | K78 |
| 79 In our school, teachers are not attending their periods                   | <input type="checkbox"/> | K79 |
| 80 I like to help my classmates with physical science                        | <input type="checkbox"/> | K80 |
| 81 My parent(s) or guardian(s) act as a volunteer in my school               | <input type="checkbox"/> | K81 |
| 82 My physical science teacher encourages me to think for myself             | <input type="checkbox"/> | K82 |
| 83 My parents (guardians) limit my privileges when I get poor symbols        | <input type="checkbox"/> | K83 |

<b>Strongly Agree =4</b>	<b>Agree = 3</b>	<b>Disagree = 2</b>	<b>Strongly Disagree = 1</b>
--------------------------	------------------	---------------------	------------------------------

- |     |  |                          |      |
|-----|--|--------------------------|------|
| 84  | I discuss with my parent(s) or guardian(s) about going to university, college or technikon         | <input type="checkbox"/> | K84  |
| 85  | I do as little work as possible in physical science  | <input type="checkbox"/> | K85  |
| 86  | My school mates dodge school or certain classes  | <input type="checkbox"/> | K86  |
| 87  | I discuss selection of subjects or streams at school with my parent(s) or guardian(s)              | <input type="checkbox"/> | K87  |
| 88  | My physical science teacher encourages me to be creative   | <input type="checkbox"/> | K88  |
| 89  | My parents (guardians) require me to do work or chores around the house                            | <input type="checkbox"/> | K89  |
| 90  | I understand the work in physical science  | <input type="checkbox"/> | K90  |
| 91  | In my physical science class, written reports are required   | <input type="checkbox"/> | K91  |
| 92  | I discuss my symbols with my parent(s) or guardian(s)  | <input type="checkbox"/> | K92  |
| 93  | My parents/guardians limit the amount of time I go out with friends                                | <input type="checkbox"/> | K93  |
| 94  | I have the ability to do well in physical science  | <input type="checkbox"/> | K94  |
| 95  | I discuss my plans and preparation for tests with my parent(s) or guardian(s)                      | <input type="checkbox"/> | K95  |
| 96  | We conduct experiments in our physical science class   | <input type="checkbox"/> | K96  |
| 97  | I discuss school activities or events of interest to me with my parents/guardians                  | <input type="checkbox"/> | K97  |
| 98  | If I was absent from school, I try to catch up with my work in physical science                    | <input type="checkbox"/> | K98  |
| 99  | We do laboratory technique skills (measuring, plotting graphs, etc.) in our physical science class | <input type="checkbox"/> | K99  |
| 100 | I do most things in physical science incorrectly   | <input type="checkbox"/> | K100 |
| 101 | I succeed in solving difficult problems in physical science  | <input type="checkbox"/> | K101 |

**Please turn over . . . . .**

**Answer each of the following questions by writing down the number that best describe your situation in the square on the right.**

102 Indicate the average amount of time you spend in a week when you do your physical science homework

- none = 1
- Less than 1 hour = 2
- Between 1 and 2 hours = 3
- Between 2 and 3 hours = 4
- More than 4 hours = 5

K102

103 In which standard (grade) are you?

- standard 7 (grade 9) = 1
- standard 8 (grade 10) = 2

K103

104 How many times before have you failed a standard (grade)?

- None = 1
- one = 2
- two = 3
- three = 4
- more than three = 5

K104

105 What percentage did you get for physical science in the last examination?

K105-106

106 What percentage did you get for English in the last examination?

K107-108

107 What percentage did you get for mathematics in the last examination?

K109-110

108 What is the level of your father's (male guardian's) formal education?

- Did not complete standard 6 = 1
- Completed standard 6, but did not go to high school = 2
- Went to high school, but did not complete standard 10 = 3
- Completed standard 10 = 4
- Completed diploma after standard 10 = 5
- Completed a Degree = 6
- Completed a Master's or Doctor's degree = 7

K111

109 What is the level of your mother's (female guardian's) formal education?

- Did not complete standard 6 = 1
- Completed standard 6, but did not go to high school = 2
- Went to high school, but did not complete standard 10 = 3
- Completed standard 10 = 4
- Completed diploma after standard 10 = 5
- Completed a Degree = 6
- Completed a Master's or Doctor's degree = 7

K112

110 What is your father's (male guardian's) occupation group?

- Unemployed = 1
- Pensioner = 2
- Garden worker, farm worker, cleaner, etc. = 3
- Service worker (police, warden, soldier, traffic officer, etc.) = 4
- Clerical worker = 5
- Businessman (own business, dealer, salesman, etc.) = 6
- Professional (teacher, nurse, doctor, engineer, accountant, etc.) = 7
- Administrator (manager, director, chief executive officer, etc.) = 8
- Other (specify) .....

K113

111 What is your mother's (female guardian's) occupation?

Unemployed, housewife	= 1	
Pensioner	= 2	
Domestic worker, cleaner, farm worker, etc.	= 3	
Service worker (police, warden, soldier, traffic officer, etc.)	= 4	
Clerical worker, secretary, typist	= 5	<input type="checkbox"/> K114
Businesswoman (own business, dealer, sales, etc.)	= 6	
Professional (teacher, nurse, doctor, engineer, accountant, etc.)	= 7	
Administrator (manager, director, chief executive officer, etc.)	= 8	
Other (specify) .....		

112 What is your gender? Female = 1 Male = 2  K115

**Which of the following do you have in your home?**

113 daily newspapers

none = 1	one = 2	two = 3	three and above = 4	<input type="checkbox"/> K116
----------	---------	---------	---------------------	-------------------------------

114 a place to do homework no = 1 yes = 2  K117

115 more than fifty books no = 1 yes = 2  K118

116 your own room no = 1 yes = 2  K119

117 a computer no = 1 yes = 2  K120

118 a telephone no = 1 yes = 2  K121

119 What is your home language?

North Sotho	= 1	
South Sotho	= 2	
Tswana	= 3	
Zulu	= 4	
Xhosa	= 5	
Tsonga	= 6	
Venda	= 7	
Swazi	= 8	
Ndebele	= 9	
Other (specify) .....		<input type="checkbox"/> K122

What is your date of birth (Year Month Day): 

1	9						
---	---	--	--	--	--	--	--

 K123-128

What is your Surname? ..... Name? .....

What is your class group? (e.g. 7B, 8E, etc.) .....   K129-130

**FOR OFFICE USE ONLY**

K131-132       K133-135       K136-138

# **APPENDIX B**



## **B1 SECOND ORDER CONFIRMATORY FACTOR ANALYSES OF HOME VARIABLES**

Three first order latent factors were postulated, namely parental involvement, parental attitudes and parental socioeconomic status. The observed variables used were:

### **Parental Involvement (PI)**

- (a) Parental Help (PHELP): the sum of items 56, 68 and 77.
- (b) Parental Control (PCONTROL): the sum of items 83, 89 and 93.
- (c) Parental Support (PSUPPORT): the sum of items 87, 97, 76, 92, 95 and 84.
- (d) Parental Participation (PPARTAKE): the sum of items 72 and 81.

### **Parental Attitudes (PA)**

- (a) Parental Encouragement (PENC): the maximum score of either item 4 or item 49.
- (b) Parental Expectations (PEXP): the maximum score of either item 7 or item 27.
- (c) Parental expectation to follow science Careers: the maximum score of either item 43 or item 46.
- (d) Parental Competence in science matters: the maximum score of either item 15 or item 19.

### **Parental Socioeconomic Status (SES)**

- (a) Parental Education (PEDU): the maximum score of either item 108 or item 109.
- (b) Parental Occupation (POCC): the maximum score of either item 110 or item 111.
- (c) Home Facilities (PFAC): the sum of items 113 to 118.

The second order confirmatory analysis model utilizing all the variables above yielded a reasonable good fit ( $\chi^2 = 138.76$ ;  $df = 41$ ;  $\chi^2/df = 3.38$ ;  $p = 0.000$ ;  $GFI = 0.951$ ;  $AGFI = 0.921$ ;  $RMR = 0.205$ ). The coefficients of determination for PPARTAKE, PCAREER, PCOMPETE and PFAC, however, were very low (see figure B.1.1). As such, these variables were left out and the model re-estimated.

The resultant model fit the data exceptionally well ( $\chi^2 = 6.66$ ;  $df = 6$ ;  $\chi^2/df = 1.11$ ;  $p = 0.353$ ;  $GFI = 0.996$ ;  $AGFI = 0.985$ ;  $RMR = 0.055$ ), further lending support to the construct validity of the questionnaire used in this study. The values of the other parameters are given in figure B.1.2. In chapter five, the variables for each first order factor were aggregated to give three indicator variables for the home factor. The rationale behind this approach was to increase parsimony of the global model.

Figure B.1.1 Initial second order confirmatory factor analysis of the home environment latent factor

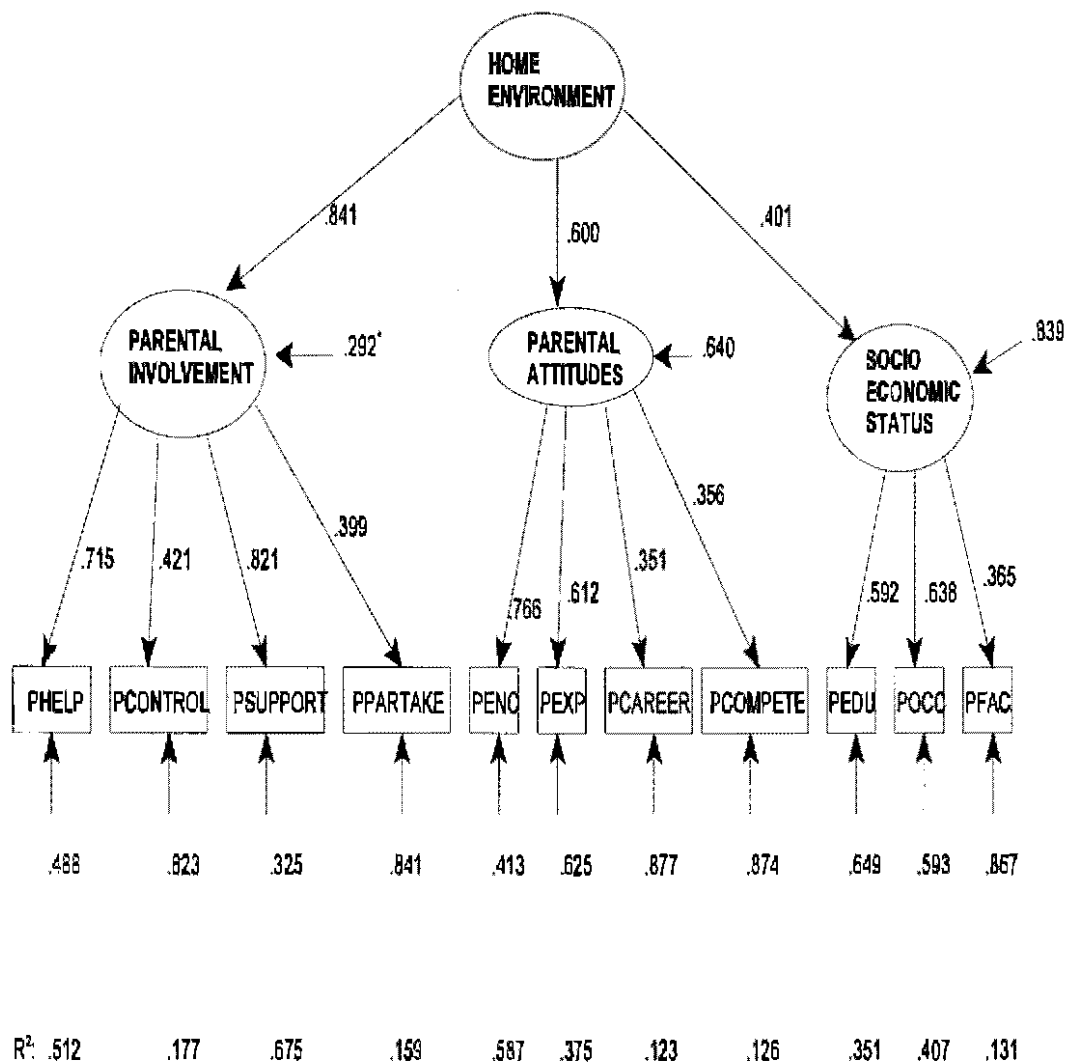

\* means non significant value

**Figure B.1.2 Revised second order confirmatory factor analysis of the home environment latent factor**

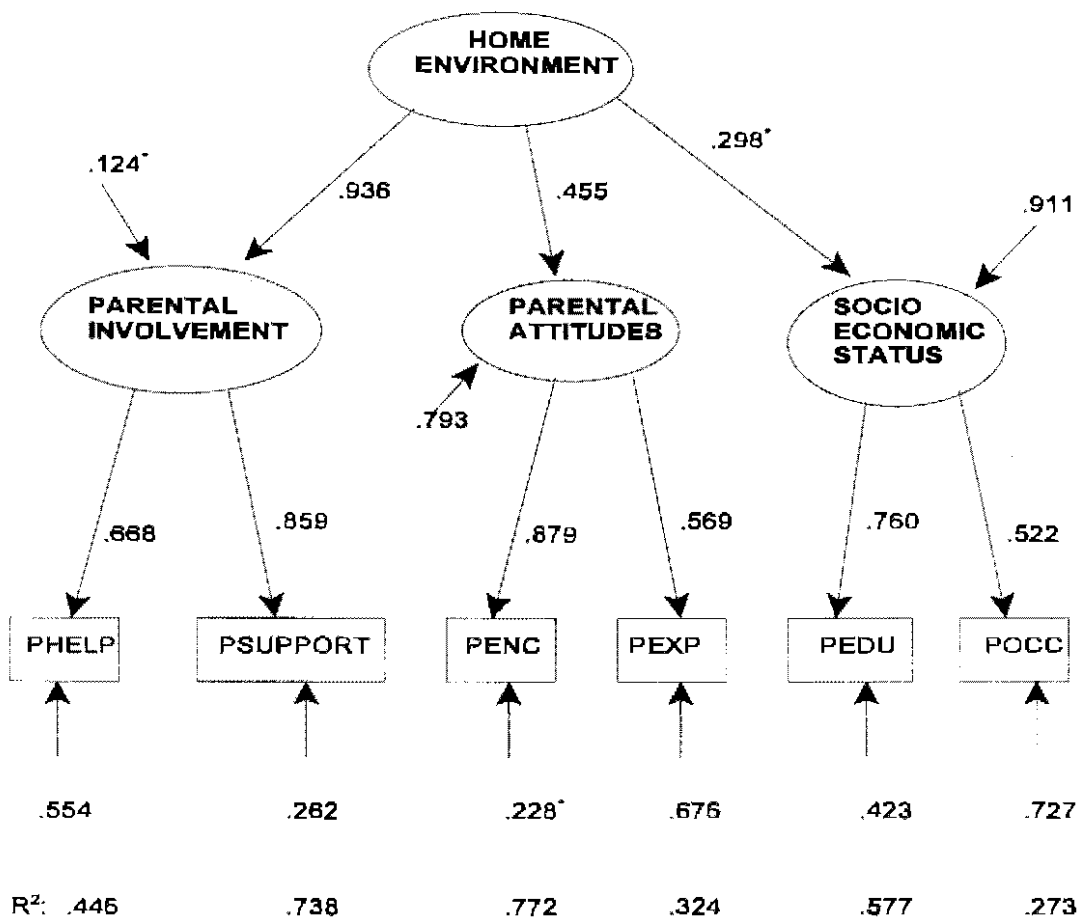

\* means non significant

## **B2 SECOND ORDER CONFIRMATORY FACTOR ANALYSES OF SCHOOL VARIABLES**

Three first order latent factors were postulated, namely teacher characteristics, school environment and instructional time. The reliability of instructional time, however, was very low and hence could not be used. The resultant two first order factors were therefore not enough for determining the second order factor of the school. Three first order factors are required to determine the second order latent factor in LISREL. An attempt to use teacher characteristics, school environment and the low reliable instructional time did not yield acceptable fits and hence there is no need to report them here.